



[Click to Learn More! >](#)

Flight Test

Aerospace Flight Test

Miniature, Triaxial, and High-Temperature Accelerometers, DC Response Accelerometers, Acoustic Microphones, Pressure Sensors, Signal Conditioning, and Accessories





Aerospace Flight Test

An Overview of Flight Test Sensing

Flight testing provides a significant challenge to the instrumentation engineer. On rocket and missile systems, data transmission occurs via radio frequency (RF) telemetry, which is often encrypted. On air and rotor craft, a lesser amount of data transmission occurs by RF transmission, while the majority is stored onboard in high capacity digital recorders. RF transmission can become constrained by factors such as flight vehicle orientation, ionization products of rocket and missile system plumes, and rotor craft blade rotation. Thus, unless real time analysis is required, onboard recording is preferred.

Hundreds to more than 1000 data channels of instrumentation may be required on a given flight vehicle. An individual data channel's frequency response allocation is typically less than 2k Hz. The routing of all of these channels to the RF transmitter(s) or recorder can require tens of miles of cables. Not every data channel is recorded on every flight. Separate measurements may be required for Vehicle State of Health monitoring (e.g., rotor craft Health Usage Monitoring (HUMS)).

Strain gages usually constitute a high percentage of data channels with accelerometers, pressure transducers, and temperature transducers all a close second. Microphones are also frequently used for measurements such as cockpit noise. Other miscellaneous sensors include angular (e.g.,

synchros) and linear (e.g., LVDTs, potentiometers) displacement transducers, flow meters, heat flux gages, torque transducers, force transducers, and more. Video is also a useful diagnostic. Instrumentation locations for aircraft can encompass the entire fuselage, wing(s), engine(s), landing gear, and empennage.

Vibratory flutter measurements enable the study of the aeroelastic stability of an aircraft so that a safe flight envelope can be defined. This study typically uses accelerometers with DC response (e.g., MEMS – 37XX Series). In some instances, dependent on aircraft size and resonant frequencies, low impedance, ICP® piezoelectric accelerometers can suffice.

Aircraft buffeting measurements result in the definition of vibration induced load inputs to the structure and components. These provide a basis for the generation of structural testing requirements. Buffeting measurements require higher frequency response than flutter and are typically made by ICP® piezoelectric accelerometers. Acceleration rigid body motion is recorded by a triaxial array of high accuracy, DC response accelerometers at the flight vehicle's center of gravity.

Flight vehicle structural design margins are assessed based on a combination of material properties (e.g., yield, ultimate, rupture) as well as fatigue considerations. Strain gages acquire these measurements. In some instances, particularly on rotor craft, structural members have strain gages configured to separate various force and moment components.

Other measurements of interest include load inputs to an air or rotor craft structure associated with landings, ordnance release, rapid application of engine thrust, turbulence, and more. DC response load cells and pressure transducers can be used for these measurements. If the measurement is sufficiently dynamic in nature, ICP® piezoelectric force and pressure transducers may be used. Last, the effect of onboard ordnance on the air or rotor craft in terms of associated aerodynamic and inertial loads and stability must also be measured.

PCB Piezotronics, Inc. manufactures transducers and signal conditioning to handle the majority of the aforementioned requirements. Specifically, PCB® offers a wide array of DC response, charge, and ICP® piezoelectric accelerometers, force transducers, and pressure transducers. In addition, an assortment of microphones, torque transducers, and high-sensitivity strain gages are available. Many of these transducers operate off of MIL-STD- 28 ± 4 VDC. The majority of manufacturers of airborne signal conditioners provide ICP®-compatible constant current supplies. All PCB transducers operate over the normal range of aerospace temperatures with some capable of operating over much wider extremes.





Flight Testing – A Varied and Complex Test Set

This “short form” catalog documents many of the sensors and signal conditioners offered by PCB Piezotronics to the flight test community. It is complemented by PCB’s other aerospace and defense sensors for other applications such as aerospace vehicle ground testing, environmental testing, Health and Usage Monitoring (HUMS), fuze/safe and arm, and blast testing, covered in the documents listed on the back of this catalog.

Because of the complexity of the flight test application and breadth of PCB’s product line, this catalog offers the most commonly used subset of PCB’s flight test sensors and signal conditioners. For a complete exploration of other options, we invite inquiries to PCB’s application engineering team (see contact information on the back of this catalog). The variety of flight test measurement requirements creates a proliferation of sensor/signal conditioning types. For example, this brief catalog contains, among others, the following sensor types, each of which is targeted at specific flight test procedures:

- Accelerometers for specialized dynamic tests such as flutter and stability/controllability characterization
- Accelerometers for load factor measurement
- High-temperature accelerometers and pressure sensors for measuring engine-excited vibration, as well as combustion and compressor instabilities
- Accelerometers and dynamic force sensors for the measurement of vehicle responses to loads for fatigue, strength, and stiffness/compliance characterization – many of these sensors may also be used for such specialized testing as aircraft carrier qualification
- Pressure sensors and microphones for characterization of cockpit/cabin, payload and external acoustic environments. These sensors span a variety of pressure dynamic ranges from low-level cabin sound pressure to launch acoustics environments to cyclic pressures capable of inducing high-cycle fatigue
- Accelerometers and dynamic pressure sensors for characterizing the interaction between engines, airborne subsystems and the vehicle structure
- Accelerometers for the measurement of the aircraft and related systems’ responses to mission, such as ordnance firing/release
- Accelerometers for the characterization of ordnance performance, related to the above
- Conveniently packaged signal conditioners that accept poorly regulated on-board power and condition signals from piezoelectric sensors
- DC accelerometers (those that measure down to zero Hz) that include internal power regulation to accept a broad range of power voltages
- Thermally insensitive piezoelectric accelerometers for rapidly changing temperature environments
- In appropriate sensors, integral temperature compensation
- Low profile accelerometers and piezoelectric pressure sensors, for minimal aerodynamic disruption
- Hermetic sensors and contamination-resistant connectors, for wet or dusty environments
- Accelerometers that meet strict outgassing limits, for space applications
- Robust connectors and cables manufactured by PCB®
- Radiation tolerant accelerometers, for space applications
- Accelerometers that tolerate shock load orders of magnitude larger than their maximum dynamic ranges
- Low impedance ICP® sensors and instrumentation that maximize electromagnetic interference rejection
- Sensors that include built-in filtering to identify customer defined performance or to protect integral amplifiers from saturation, for specific applications

Compounding the complexities of meeting such a variety of measurement types, the flight test environment is particularly challenging.

Flight Testing – A Demanding Application

Flight testing presents some of the test community’s greatest challenges. It is extremely expensive, test article availability is inevitably limited, timeframes are often compressed and unpredictable, and the sensors with associated instrumentation have to perform properly on the first attempt, even in rigorous environments. This testing can be a single event or it may encompass multiple tests over months or even years.

Through decades of collaboration with flight test engineers, PCB® has developed a set of sensors and signal conditioners tailored to flight test’s demanding environments. These include:

- Internally amplified (ICP®) triaxial accelerometers, as small as a 0.25 inch cube, that add minimal weight and occupy very little volume

With all these challenges, PCB® recognizes the importance of working closely with flight test instrumentation engineers and sharing lessons learned over the years. In fact, many of our “flight test” sensors started their lives as “specials” designed and built for specific flight test programs.

PCB’s Offering to the Flight Test Community

Building upon a foundation of one of the world’s largest and most diverse sensor and related electronics product lines, the sensors and signal conditioning included in this catalog measure:

- Acceleration from DC (e.g., due to load factors and gravity) to very high frequencies across dynamic ranges measured in micro-g’s up to a maximum of 120,000 g’s
- Pressure from acoustic levels to 100,000 psi or more, and from DC to hundreds of kHz
- Force and torque sensors for both static and dynamic measurement applications

Complementing PCB’s sensor line is signal conditioning, specifically designed for aerospace vehicle power availability, severe vibration environments, challenging EMI conditions, constrained space requirements, and the temperature extremes encountered in flight testing.

PCB’s instrumentation and electronic engineering staff is experienced in design for flight test applications. We can quickly and efficiently modify sensors and electronics for specific or unique flight requirements, when necessary. PCB’s long standing commitment to **Total Customer Satisfaction** extends to the willingness to devote engineering and manufacturing resources to such unique and challenging requirements.



Single Axis, Piezoelectric Accelerometers for Vibration and Flutter Measurement

PCB® offers various types of accelerometers to suit all applications.

- The teardrop accelerometers are very small and lightweight. This design exhibits minimum mass loading effects and installs adhesively into tight locations.
- The through hole or ring-type configurations install conveniently with a through bolt which may be rotated to achieve desired location of electrical connection. Ring-type accelerometers are also low profile, allowing installation in tight areas.

Single Axis, Piezoelectric Accelerometers

Model Number	352C23	352C22	352A24	353B15	355B12	355B03	355B34	355B33
Sensitivity (nominal)	5 mV/g	10 mV/g	100 mV/g	10 mV/g	10 mV/g	100 mV/g	10 mV/g	100 mV/g
Measurement Range	± 1000 g pk	± 500 g pk	± 50 g pk	± 500 g pk	± 500 g pk	± 50 g pk	± 500 g pk	± 50 g pk
Broadband Resolution	0.003 g rms	0.002 g rms	0.0002 g rms	0.005 g rms	0.0005 g rms	0.0001 g rms	0.001 g rms	0.0005 g rms
Frequency Range (± 10%)	1.5 Hz to 15k Hz	0.7 Hz to 13k Hz	0.8 Hz to 10k Hz	0.7 Hz to 18k Hz	0.6 Hz to 15k Hz	0.6 Hz to 12k Hz	1 Hz to 7k Hz	1 Hz to 10k Hz
Resonant Frequency	≥ 70k Hz	≥ 50k Hz	≥ 30k Hz	≥ 70k Hz	≥ 50k Hz	≥ 35k Hz	≥ 25k Hz	≥ 25k Hz
Temperature Range	-65 to +250 °F -54 to +121 °C	-65 to +250 °F -54 to +121 °C	-65 to +250 °F -54 to +121 °C	-65 to +250 °F -54 to +121 °C	-65 to +250 °F -54 to +121 °C	-65 to +250 °F -54 to +121 °C	-65 to +250 °F -54 to +121 °C	-65 to +250 °F -54 to +121 °C
Sensing Element	Ceramic/Shear	Ceramic/Shear	Ceramic/Shear	Quartz/Shear	Ceramic/Shear	Ceramic/Shear	Quartz Shear	Quartz Shear
Electrical Connector	3-56 Coaxial Jack	3-56 Coaxial Jack	3-56 Coaxial Jack	5-44 Coaxial Jack	5-44 Coaxial Jack	10-32 Coaxial Jack	10-32 Coaxial Jack	10-32 Coaxial Jack
Electrical Isolation	Yes	Yes	Yes	No	Yes	Yes	Yes	Yes
Housing Material	Anodized Aluminum	Anodized Aluminum	Anodized Aluminum	Titanium	Titanium	Titanium	Titanium	Titanium
Sealing	Epoxy	Epoxy	Epoxy	Welded Hermetic	Welded Hermetic	Hermetic	Hermetic	Hermetic
Weight	0.2 gm	0.5 gm	0.8 gm	2.0 gm	2.3 gm	10 gm	11 gm	11 gm
Size (H x L x W)	0.11 x 0.34 x 0.16 in 2.8 x 8.6 x 4.1 mm	0.14 x 0.45 x 0.25 in 3.6 x 11.4 x 6.4 mm	0.19 x 0.48 x 0.28 in 4.8 x 12.2 x 7.1 mm	0.31 x 0.43 in [1] 7.9 in x 10.9 mm	0.23 x 0.64 x 0.38 in 5.84 x 16.4 x 9.6 mm	0.95 x 0.63 in [2] 24.1 x 16.0 mm	0.40 x 0.70 x 0.63 in 10.2 x 17.8 x 15.9 mm	0.40 x 0.70 x 0.63 in 10.2 x 17.8 x 15.9 mm
Mounting	Adhesive	Adhesive	Adhesive	5-40 Stud	Through Hole	Through Hole	Through Hole	Through Hole
Supplied Accessories								
Cable	030A10	030A10	030A10	—	—	—	—	—
Wax/Adhesive	080A109	080A109	080A109	080A109	—	080A109	080A109	080A109
Removal Tool	039A26	039A27	039A28	—	039A20	039A22	039A22	039A22
Adhesive Mounting Base	—	—	—	080A15	—	—	—	—
Mounting Stud/Screw	—	—	—	—	081B36	081B45	081B45	081B45
Additional Versions								
Titanium Housing	—	352A21	—	—	—	—	—	—
Metric Mounting Thread	—	—	—	M353B15	M355B12	M355B03	—	—
Notes								
[1] Hex x Height [2] Length x Width								

This is a small sample of PCB's ICP® accelerometer offering. Refer to PCB's Test & Measurement catalog or www.pcb.com.



Triaxial, Piezoelectric Accelerometers for Vibration and Flutter Measurement

PCB® provides a large range of sizes in triaxial accelerometers.

- Miniature triaxial accelerometers are especially well-suited for applications demanding high frequency range, small size and light weight.
- High temperature, charge output, triaxial accelerometers (found on page 6) deliver high-impedance measurement signals directly from their piezoelectric sensing elements. No internal circuitry is used, which permits operation to extreme temperatures.
- Triaxial accelerometers, used for structural analysis, are constructed of aluminum or titanium for the lowest mass, and exhibit excellent phase response and measurement resolution.

Triaxial, Piezoelectric Accelerometers						
Model Number	356A01	356A13	356A15	354C10	354C02	354C03
Sensitivity (nominal)	5 mV/g	5 mV/g	100 mV/g	10 mV/g	10 mV/g	100 mV/g
Measurement Range	± 1000 g pk	± 1000 g pk	± 50 g pk	± 500 g pk	± 500 g pk	± 50 g pk
Broadband Resolution	0.003 grms	0.003 grms	0.0002 g rms	0.003 g rms	0.0005 g rms	0.0002 g rms
Frequency Range (± 5%)	1 Hz to 5k Hz	1 Hz to 5k Hz	2 Hz to 5k Hz	2 Hz to 8k Hz	0.3 Hz to 4k Hz [2]	0.3 Hz to 4k Hz [2]
Resonant Frequency	≥ 50k Hz	≥ 50k Hz	≥ 25k Hz	≥ 40k Hz	≥ 12k Hz	≥ 12k Hz
Temperature Range	-65 to +250 °F -54 to +121 °C	-65 to +250 °F -54 to +121 °C	-65 to +250 °F -54 to +121 °C	-65 to +250 °F -54 to +121 °C	-65 to +250 °F -54 to +121 °C	-65 to +250 °F -54 to +121 °C
Sensing Element	Ceramic/Shear	Ceramic/Shear	Ceramic/Shear	Ceramic/Shear	Ceramic/Shear	Ceramic/Shear
Electrical Connector	Integral Cable	Integral Cable	1/4-28 4-Pin Jack	Integral Cable	1/4-28 4-Pin Jack	1/4-28 4-Pin Jack
Electrical Ground Isolation	No	No	No	Yes	Yes	Yes
Housing Material	Titanium	Titanium	Titanium	Titanium	Titanium	Titanium
Sealing	Hermetic	Hermetic	Hermetic	Hermetic	Hermetic	Hermetic
Weight	1.0 gm	1.0 gm	5.4 gm	5.0 gm	15.5 gm	15.5 gm
Size (H x L x W)	0.25 in Cube 6.35 mm Cube	0.25 x 0.375 x 0.25 in 6.35 x 9.53 x 6.35 mm	0.45 in Cube 11.4 mm Cube	0.30 x 0.55 x 0.55 in 7.6 x 14 x 14 mm	13/16 x 0.45 in [1] 13/16 in x 11.4 mm	13/16 x 0.45 in [1] 13/16 in x 11.4 mm
Mounting	Adhesive	Adhesive	5-40 Thread	Through Hole	Through Hole	Through Hole
Supplied Accessories						
Cable	034G05	034G05	—	034G05	—	—
Wax/Adhesive	080A109/080A90	080A109 / 080A90	080A109	—	080A109	080A109
Adhesive Mounting Base	—	—	080A	—	—	—
Mounting Stud/Screw	—	—	081A27 / M081A27	081B93	081B60	081B60
Removal Tool	—	—	—	039A21	039A23	039A23
Additional Versions						
Metric Mounting Thread	—	—	M354C03	M354C10	M354C02	M354C03
Integral Cable	Standard	Standard	—	Standard	—	—
Notes						
[1] Hex x Height [2] Range shown is ± 10%						

This is a small sample of PCB's triaxial accelerometer offering. Refer to PCB's Test & Measurement catalog or search "triaxial accelerometer" at www.pcb.com.

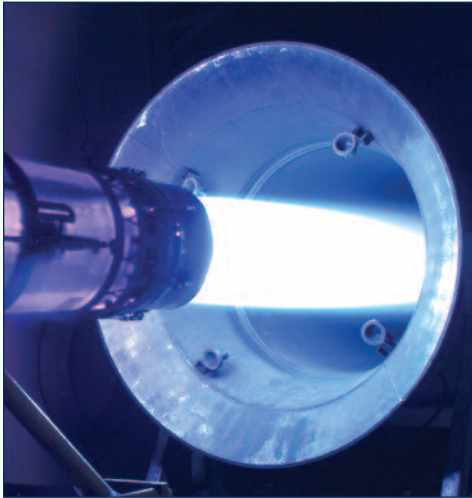

High Temperature Accelerometers

Many operating engine environments generate temperatures in excess of 550 °F (288 °C). Above this temperature, many of the design features and materials used in high temperature accelerometers change considerably.

For 550 °F to 1,200 °F (288 °C to 650 °C) operating environments, PCB® offers a range of both single-ended (measurement output as a signal and ground) and differential (measurement output as a plus and minus signal) sensors. The former tend to be smaller and more suitable for short-term testing needs, while the latter are more appropriate for long-term monitoring applications.

Obviously, the environments in which these sensors operate are challenging. In fact, in some of the highest temperature operating environments, the operating sensor measures vibration signatures while glowing red hot!

These sensors are complemented by both lab-grade and in-line charge amplifier systems. This differential charge amplifier is suitable for interfacing to any of PCB's differential charge output accelerometers.

The accelerometers and charge amplifiers summarized here are only a small subset of the available sensors that are documented in PCB's Test and Measurement Catalog or on our web site at www.pcb.com. Of course, custom designed accelerometers are always available.

	Charge Output Output 500 °F/260 °C	Charge Output 900 °F/ 482 °C	Charge Output 490 °F/ 254 °C	Differential Output 550 °F/ 288 °C		Differential Output 900 °F/ 482 °C		Single-Ended 1200 °F/ 650 °C
Model Number	357B06	357B69	356A71	357B81	357B83	357C71	357C72	357C90
Sensitivity (nominal)	5 pC/g	3 pC/g	10 pC/g	20 pC/g	100 pC/g	10 pC/g	50 pC/g	5 pC/g
Measurement Range	± 1000 g pk	± 500 g pk	± 500 g pk	± 2000 g pk	± 500 g pk	± 1000 g pk	± 500 g pk	± 1000 g pk
Broadband Resolution	[1]	[1]	[1]	[1]	[1]	[1]	[1]	[1]
Frequency Range (± 5%)	10k Hz	6k Hz	7k Hz	9k Hz	6k Hz	4k Hz	2.5k Hz	3k Hz
Resonant Frequency	≥ 50k Hz	≥ 35k Hz	≥ 25k Hz	≥ 35k Hz	≥ 20k Hz	≥ 25k Hz	≥ 13k Hz	≥ 15k Hz
Temperature Range	-65 to +500 °F -54 to +260 °C	-65 to +900 °F -54 to +482 °C	-95 to +490 °F -70 to +254 °C	-65 to +550 °F -54 to +288 °C	-65 to +550 °F -54 to +288 °C	-65 to +900 °F -54 to +482 °C	-65 to +900 °F -54 to +482 °C	-65 to +1200 °F -54 to +649 °C
Sensing Element	Ceramic/Shear	Ceramic/Compression	Ceramic/Shear	Ceramic/Shear	Ceramic/Shear	Ceramic/Compression	Ceramic/Compression	Shear
Electrical Connector	5-44 Jack	10-32 Jack	10-32 Coaxial Jack	7/16-27 2-Pin	7/16-27 2-Pin	7/16-27 2-Pin	7/16-27 2-Pin	10-32 Coaxial Jack
Electrical Case Isolation	No	No	No	Yes	Yes	Yes	Yes	Yes
Housing Material	Titanium	Inconel	Titanium	Stainless Steel	Stainless Steel	Inconel	Inconel	Inconel
Sealing	Welded Hermetic	Hermetic	Hermetic	Welded Hermetic	Welded Hermetic	Welded Hermetic	Welded Hermetic	Welded Hermetic
Weight	2.3 gm	17.8 gm	22.7 gm	50 gm	50 gm	75 gm	110 gm	75 gm
Size (Height x Dia.)	0.23 x 0.63 x 0.38 in. 5.8 x 16.4 x 9.6 mm [2]	0.875 x 0.45 in 22.2 x 11.4 mm [2]	0.5 x 0.96 x 1.0 in 12.7 x 24.4 x 25.4 mm	1.0 x 0.75 in 25.4 x 19 mm	1.0 x 0.75 in 25.4 x 19 mm	1.0 x 0.75 in 25.4 x 19 mm	1.25 x 0.75 in 31.8 x 19 mm	0.66 x 1.26 x 0.66 in 16.7 x 32 x 16.7 mm [2]
Mounting	Through Hole	10-32 Thread	Through Hole	Through Hole	Through Hole	Through Hole	Through hole	Through Hole
Supplied Accessories								
Cable	—	—	—	—	—	—	—	MI Hardline Cable with SS Braid
Mounting Stud/Screw	—	081A107/ M081A107	—	081A99 (3)	081A99 (3)	081A99 (3)	081A99 (3)	081A108
Wax/Adhesive	—	—	080A90	—	—	—	—	—
Tool	089A20	—	039A22	—	—	—	—	—
Adhesive Mounting Base	—	—	080A170	—	—	—	—	—
Cap Screw	081B36	—	081A94	—	—	—	—	—
Additional Accessories								
Mating Cable Connectors	AG	—	—	GN	GN	GN	GN	EB
Recommended Cables	003	—	—	013	013	013	013	003
Metric Mounting Thread	M357B06	—	M356A71	—	—	—	—	—
Notes								
[1] Resolution is dependent upon cable length and signal conditioner [2] Height x Length x Width								

This is a small sample of PCB's high temperature offering. Refer to PCB's Test & Measurement catalog or search "high temperature accelerometer" or "charge converter" at www.pcb.com.



Low Temperature Coefficient Accelerometers

High and low temperature extremes and thermal transients can play havoc with the quality of your data. Piezoelectric crystals are required for accurate and efficient dynamic measurements at temperature extremes, and during fast thermal gradients often exhibit undesired spiking phenomena. PCB® has developed a family of accelerometers employing new crystal designs and processes pioneered at PCB®, to minimize and eliminate this effect.

Low Temperature Coefficient Accelerometers			
	Triax		Single axis
Model Number	339A30	339A32	320C03
Sensitivity (nominal) [2]	10 mV/g	10 mV/g	10 mV/g
Measurement Range	± 500 g pk	± 500 g pk	± 500 g pk
Broadband Resolution	0.008 g rms	0.003 g rms	0.005 g rms
Frequency Range (± 5%)	2 Hz to 10k Hz	2 to 8k Hz	1 Hz to 6k Hz
Resonant Frequency	≥ 25k Hz	≥ 45 kHz	≥ 35k Hz
Temperature Range	-65 to +325 °F -54 to +163 °C	-65 to +325 °F -54 to +163 °C	-100 to +325 °F -73 to +163 °C
Sensing Element	Shear		Quartz Shear
Electrical Connector	8-36 4-Pin Jack	8-36 4-Pin Jack	10-32 Jack
Housing Material	Titanium	Titanium	Titanium
Sealing	Welded Hermetic	Welded Hermetic	Welded Hermetic
Weight	4.0 gm	3.6 gm	10.5 gm
Size	0.4 in Cube 10.2 mm Cube	0.28 x 0.47 x 0.47 in 7.0 x 12.0 x 12.0 mm	0.50 x 0.81 in 12.7 x 20.6 mm [1]
Mounting	Adhesive	Adhesive	10-32 Thread
Supplied Accessories			
Cable	034K10	034K10	—
Wax/Adhesive	080A109 / 080A90	080A109 / 080A90	080A109
Mounting Stud/Screw	—	—	081B05 / M081B05
Notes			
[1] Hex x Height [2] Range shown is ± 10%			

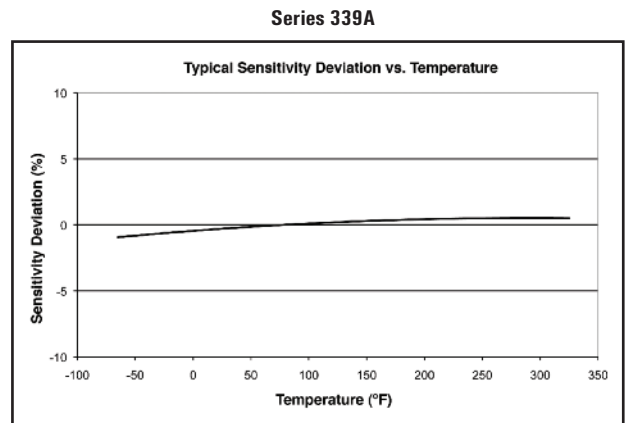
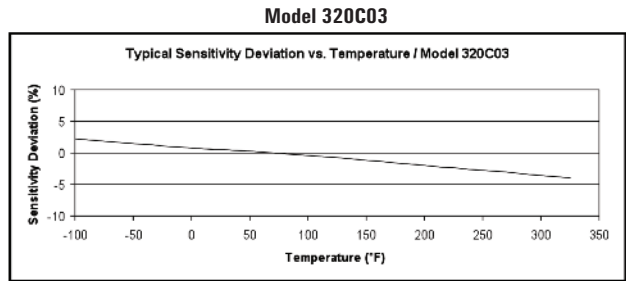

Transducer Electronic Data Sheet (TEDS)

A sensor incorporating a Transducer Electronic Data Sheet (TEDS) is a mixed-mode (analog/digital) sensor with a built-in read/write memory that contains information about the sensor and its use. A TEDS sensor has an internal memory that includes information about the manufacturer, specifications, and calibration, defined by IEEE standard 1451.4, effectively giving it the ability of “plug-and-play” self-identification within a measurement system. Using the same two-wire design of traditional piezoelectric with internal charge amplifier transducers, the TEDS sensor can flip between analog and digital modes, functioning with either a typical analog output, or with a digital bit stream output. Although a TEDS sensor can be connected to any ICP® sensor signal conditioner, only a TEDS capable ICP® signal conditioner and data acquisition equipment support the digital communication mode.

Most PCB® accelerometers are available to order with TEDS functionality by specifying the unit's model number with a “T” prefix. Model 400B76 TEDS sensor interface kit provides users with full access to support both reading and writing information to the TEDS sensor. Its Windows® GUI supports both IEEE and LMS templates, communicating with a TEDS sensor over a USB port. Model 400B76-T includes an adaptor that allows reading and writing to triaxial accelerometers with one mouse click.

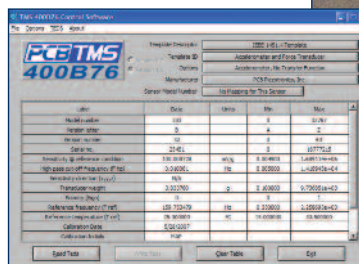



MEMS DC Response Accelerometers

PCB® Series 3711 (single axis), 3713 (triaxial), and 3741(single axis) MEMS DC response accelerometers are designed to measure low-frequency vibration and motion and are offered in full-scale ranges from ± 2 to ± 200 g to accommodate a variety of testing requirements. The units feature gas-damped, silicon MEMS sensing elements for uniform, repeatable performance and offer high frequency overload protection.

Electrically, the units offer a single-ended or differential output signal with power, signal, and ground leads for each channel. Supply voltage regulation permits operation from + 6 to + 30 VDC and the low-noise, low-impedance output signal may be transmitted over long cable lengths without degradation.

Rugged and Durable Series 3711 & 3713 MEMS DC Response

sensors are hermetically sealed in a robust titanium housing allowing for a very stable and accurate measurement in the most severe operating environments. In addition, this series is inherently insensitive to base strain and transverse acceleration effects. Supply voltage regulation permits operation from + 6 to + 30 VDC and the single-ended, low-noise, low-impedance output signal may be transmitted over long cable lengths without degradation. The series is available in single axis and triaxial versions with a 10 ft (3 m) integral cable or a multi-pin, threaded, electrical connector for easy installation and setup.



Series 3711B11



Series 3713B11



Series 3711B12 (with integral cable)



Series 3713B12 (with integral cable)

Precision Series 3741 MEMS DC Response

sensors are low-profile and low-mass with mechanical overload stops and a hard-anodized aluminum housing for added durability. The units offer a differential output signal for common-mode noise rejection and incorporate many advanced features including supply voltage regulation and a proprietary temperature compensation circuit for stable performance over the entire operational temperature range. Each unit is provided with an integral, 4-conductor, 10 ft (3 m) shielded cable. An optional mounting adaptor, Model 080A208, facilitates triaxial measurement configurations.



Series 3741B

Single Ended Output – MEMS DC Response

Sensitivity	Measurement Range (pk)	Frequency ($\pm 5\%$)	Broadband Resolution (rms)
10 mV/g	± 200 g	0 to 850 Hz	21.1 mg
40 mV/g	± 50 g	0 to 1000 Hz	6.0 mg
66.7 mV/g	± 30 g	0 to 1000 Hz	3.5 mg
66.7 mV/g, 2.5 V offset	± 30 g	0 to 25 Hz	2.4 mg
200 mV/g	± 10 g	0 to 1000 Hz	1.2 mg
1000 mV/g	± 2 g	0 to 250 Hz	0.25 mg

Model Number	3711 Single Axis	3713 Triaxial
Overload Limit (Shock)	± 3000 g pk	± 3000 g pk
Temperature Range	-65 to +250 °F -54.0 to +121 °C	-65 to +250 °F -54 to +121 °C
Excitation Voltage	6 to 30 VDC	6 to 30 VDC
Housing Material	Titanium	Titanium
Sealing	Hermetic	Hermetic
Size (H x L x W)	0.45 x 0.85 x 0.85 in 11.4 x 21.6 x 21.6 mm	0.8 in Cube 20.3 mm Cube
Weight	Connector style Integral cable style	17.3 gm 119.0 gm
Electrical Connector	1/4-28 4-Pin or 10 ft. (3 m) Integral Cable	9-Pin or 10 ft. (3 m) Integral Cable

Supplied Accessories

Easy Mount Clip	080A152	—
Adhesive Base	—	080A12
Mounting Screw/Stud	081A113 M081A113	081B05 M081B05

Additional Accessories

Triaxial Mounting Block	080A153	—
Mounting Cable Connector	AY	EN
Recommended Cable	010	037

Differential Output – MEMS DC Response

Sensitivity	Measurement Range (pk)	Frequency ($\pm 5\%$)	Broadband Resolution (rms)
10 mV/g	± 200 g	0 to 850 Hz	21.1 mg
20 mV/g	± 100 g	0 to 1000 Hz	12.0 mg
40 mV/g	± 50 g	0 to 1000 Hz	5.2 mg
66.7 mV/g	± 30 g	0 to 1000 Hz	3.5 mg
200 mV/g	± 10 g	0 to 1000 Hz	1.2 mg
1000 mV/g	± 2 g	0 to 250 Hz	0.25 mg

Overload Limit (Shock)	± 3000 g pk
Temperature Range	-65 to +250 °F -54 to +121 °C
Excitation Voltage	6 to 30 VDC
Housing Material	Anodized Aluminum
Sealing	Epoxy
Size (H x L x W)	0.30 x 1.00 x 0.85 in 7.62 x 25.4 x 21.6 mm
Weight (without cable)	9.9 gm
Electrical Connector	10 ft (3 m) Integral Cable

Supplied Accessories

Mounting Screws/Studs	(2) 081A103 (2) M081A103
-----------------------	-----------------------------

Additional Accessories

Triaxial Mounting Block	080A208
-------------------------	---------

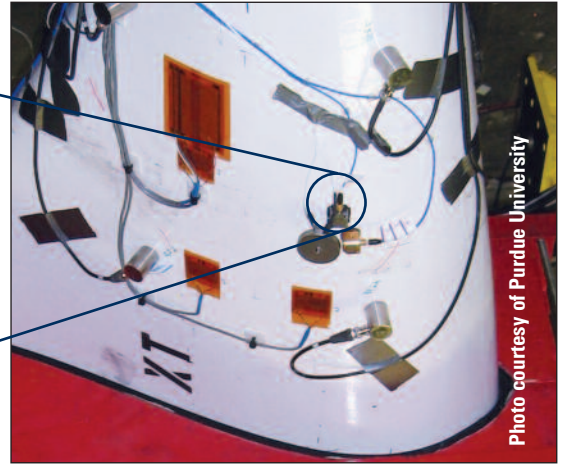
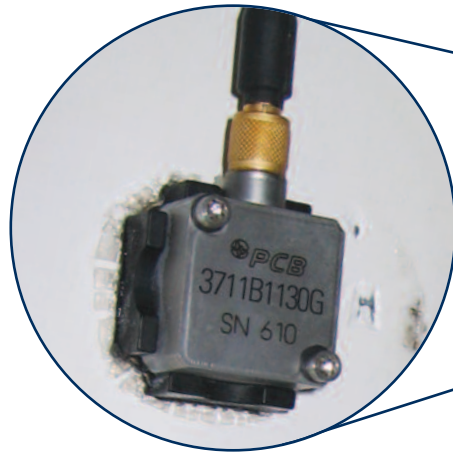

Photo courtesy of Purdue University

Model Numbering System

1) Series

- 3741B Single axis, MEMS DC response accelerometer
- 3713B Triaxial, MEMS DC response accelerometer
- 3711B Single axis, MEMS DC response accelerometer

2) Cable

- 11 Multi-pin, threaded, electrical connector (3711 & 3713 only)
- 12 Standard, 10 ft. (3.0 m) integral cable and pigtail termination

3) Measurement Range

- 2G ± 2 g measurement range corresponding to 1000 mV/g sensitivity
- 10G ± 10 g measurement range corresponding to 200 mV/g sensitivity
- 30G ± 30 g measurement range corresponding to 66.7 mV/g sensitivity
- 50G ± 50 g measurement range corresponding to 40 mV/g sensitivity
- 100G ± 100 g measurement range corresponding to 20 mV/g sensitivity (Series 3741 only)
- 200G ± 200 g measurement range corresponding to 10 mV/g sensitivity

4) Integral Cable Length (add only if selecting internal cable other than standard 10 ft - 3.0 m - length)

/XXX Specify XXX as desired cable length in feet (specify MXXX for desired cable length in meters)

5) Cable Termination

- AY 4-pin plug (Series 3711 & 3741 only)
- DZ Pigtail, stripped and tinned ends (Series 3711 & 3713 only)
- EN 9-pin plug (Series 3713B11 only)
- HW 9-pin D-sub plug for mating to Model 478A30 signal conditioner (Series 3741 only)
- LN 8-pin mini DIN for mating to Models 482C27 or 483C28 signal conditioners (Series 3741 only)
- LT 8-pin mini DIN for mating to Models 482C27 or 483C28 signal conditioners (Series 3711 only)

Example

3713B 11 10G /005 DZ Single axis MEMS DC response accelerometer, ± 10 g measurement range, 5 ft. (1.5 m) integral cable pigtail

Additional Version

3711B 03 Single axis MEMS DC response accelerometer; multi-pin, threaded, electrical connector; ± 30 g measurement range; low pass filter; 2.5 V offset

Accessories



Model 010D10 Cable
10 ft (3 m)
4-pin plug to 4-pin plug



Model 037P10 Cable
10 ft (3 m)
9-pin plug to pigtails



Model 080A153
Triaxial Mounting Block



Model 080A152
Easy Mount Clip



Series 3711 shown mounted
in Easy Mount Clip









Flight Test



Microphones

PCB Piezotronics offers a variety of acoustic measurement products, including condenser, modern prepolarized, traditional externally polarized, array, probe, low-profile surface, and special-purpose microphones. Microphone products are complemented by an assortment of preamplifiers, signal conditioners, A-weighting filters, handheld calibrators, and accessories. A large number of established aerospace, military and defense, automotive, universities, OEM's, consultants, and white goods (appliance) manufacturers have trusted their test requirements to PCB®.

The following selection is an example of PCB's wide range of acoustic sensors and accessories. For a complete overview of both products and applications, please refer to our dedicated acoustics brochure from PCB's Aerospace and Defense Division.

	Prepolarized (0V) Precision Condenser Microphones				Externally-polarized (200V) Precision Condenser Microphones	
						
Model Number	377C01	377A12	377B02	377B20	2540	2570
Nominal Microphone Diameter	1/4" 6.3 mm	1/4" 6.3 mm	1/2" 12.5 mm	1/2" 12.5 mm	1/2" 12.5 mm	1" 25.4 mm
Response Characteristic	Free-Field	Pressure	Free-Field	Random Incidence	Free-Field	Free-Field
Nominal Open Circuit Sensitivity	2 mV/Pa	0.25 mV/Pa	50 mV/Pa	50 mV/Pa	14.5 mV/Pa	48 mV/Pa
Frequency Range (± 5%)	5.4 Hz to 80k Hz	4 Hz to 20k Hz	3.14 Hz to 20k Hz	3.14 Hz to 12.5k Hz	4 Hz to 40k Hz	2.6 Hz to 20k Hz
Dynamic Range - 3% Distortion Limit [1]	165 dB	187 dB	146 dB	146 dB	160 dB	146 dB
Dynamic Range - Cartridge Thermal Noise [1]	28 dB (A)	68 dB (A)	15 dB (A)	15 dB (A)	20 dB (A)	10 dB (A)
Operating Temperature Range	-40 to +248 °F -40 to +120 °C	-40 to +248 °F -40 to +120 °C	-40 to +248 °F -40 to +120 °C	-40 to +248 °F -40 to +120 °C	-40 to +302 °F -40 to +150 °C	-40 to +302 °F -40 to +150 °C
Polarization Voltage	0V (2 to 20 mA)	0V (2 to 20 mA)	0V (2 to 20 mA)	0V (2 to 20 mA)	200V	200V
Additional Accessories						
Holder	079A10/079B23	079A10/079B23	079A11/079B23	079A11/079B23	079A11/079B23	079A11/ 079B23, 079B25
Stands	079A15/079A16, 079A18	079A15/079A16, 079A18	079A15/079A16, 079A18	079A15/079A16, 079A18	079A15/079A16, 079A18	079A15/ 079A16, 079A18
Windscreens	079A07	079A07	079A06	079A06	079A06	N/A
Recommended Preamplifiers	426B03	426B03	426E01/426A10, 426A11/HT426E01	426E01/426A10, 426A11/HT426E01	426A30	426A30
Recommended Cables	002 Low Cost, 003 CE	002 Low Cost, 003 CE	002 Low Cost, 003 CE	002 Low Cost, 003 CE	011	011
Adaptor	—	—	—	—	—	079B25
Additional Versions						
TEDS Microphone and Preamplifier Systems	378C01/TLD378C01	378A12/TLD378A12	378B02/TLD378B02	378B20/TLD378B20		
Notes						
[1] re 20 µPa						

This is a small sample of PCB's microphone offering. Refer to PCB's Test & Measurement catalog or search "377" at www.pcb.com.

Preamplifiers Designed for Prepolarized and Externally Polarized Precision Condenser Microphones

Modern Prepolarized and Traditional, Externally-Polarized Precision Condenser Microphones

A wide variety of traditional, externally-polarized and modern prepolarized free-field, pressure, and random incidence precision condenser microphones are available from PCB®. Externally-polarized models operate from a 200 V power source, while prepolarized models can operate from low cost, constant current (2 to 20 mA) ICP® signal conditioners. Externally polarized microphones can be interchanged with similar ICP® accelerometer set-ups, allowing tests and measurements with same data acquisition system. Furthermore, they show excellent performance suitable for aerospace and defense dedicated testing.

- Proven ruggedized design
- Exceptional performance in high humidity
- Individually tested for performance
- Meet IEC and ANSI standards
- Can be utilized in Type 1 systems
- Operate from ICP® sensor power (prepolarized)



This is a small sample of PCB's microphone offering. Refer to PCB's Test & Measurement catalog or search "426" at www.pcb.com.

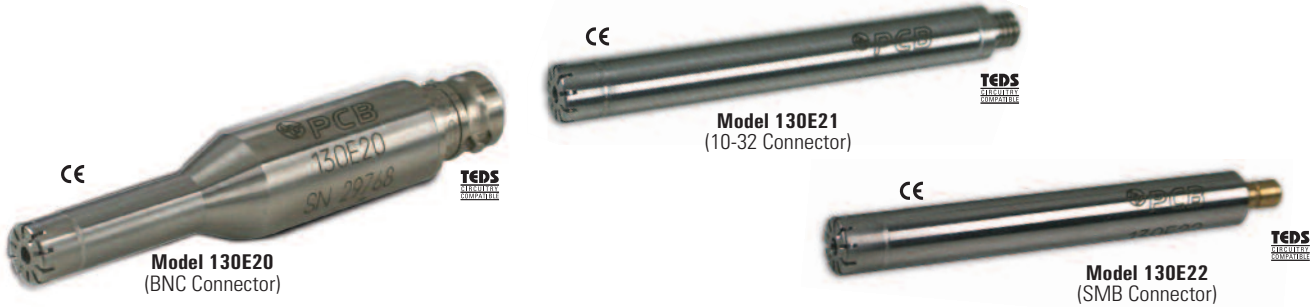

ICP® Array Microphones with Integral Preamplifier

Model Number	130E20	130E21	130E22
Microphone Diameter	1/4 in	1/4 in	1/4 in
Response	Free-Field	Free-Field	Free-Field
Sensitivity (± 3 dB at 250 Hz)	45 mV/Pa	45 mV/Pa	45 mV/Pa
Frequency Response (± 2 dB)	20 to 10k Hz	20 to 10k Hz	20 to 10k Hz
Frequency Response (± 5 dB)	20 to 20k Hz	20 to 20k Hz	20 to 20k Hz
Dynamic Range	< 30 to > 122 dB	< 30 to > 122 dB	< 30 to > 122 dB
Polarization Voltage	0 V	0 V	0 V
Temperature Range	+14 to +122 °F -10 to +55 °C	+14 to +122 °F -10 to +55 °C	+14 to +122 °F -10 to +55 °C
Connector	BNC Jack	10-32 Jack	SMB Socket
TEDS IEEE 1451.4	Included	Included	Included

This is a small sample of PCB's microphone offering. Refer to PCB's Test & Measurement catalog or search "130" at www.pcb.com.

Microphone Accessories

Microphone Power Supply

- 0 and 200 volt polarization voltage
- Extended battery life (40 hours)
- 0, 20, and 40 dB gain
- Selectable flat (Z), A, and C-weighting



Model 480A25
Microphone Preamplifier Power Supply

Microphone Calibrators



Model CAL200
Acoustic Calibrator



Model CAL250
Acoustic Calibrator



Model 394A40
Pistonphone Calibrator





Series 103B ICP® High-intensity, Sound Pressure Sensors

PCB® Series 103B has played a major role in the development of supersonic aircraft and rockets. This tiny instrument is also useful for measuring transient pressure events, air turbulence, and other such acoustic phenomena on structures or aerodynamic models.

- Capable of high-intensity sound measurement of 191 dB with 86 dB resolution
- Acceleration compensated, ceramic element virtually eliminates vibration sensitivity



Models
103B01 & 103B11 **Models**
103B02 & 103B12

High Sensitivity, ICP® Acoustic Pressure Sensors

Model Number	103B01	103B11	103B02	103B12
Measurement Range	3.3 psi 181 dB	10 psi 191 dB	3.3 psi 181 dB	10 psi 191 dB
Useful Overrange	6.7 psi [1] 187 dB [1]	20 psi [1] 197 dB [1]	6.7 psi [1] 187 dB [1]	20 psi [1] 197 dB [1]
Sensitivity	1500 mV/psi 217.5 mV/kPa	500 mV/psi 72.5 mV/kPa	1500 mV/psi 217.5 mV/kPa	500 mV/psi 72.5 mV/kPa
Maximum Dynamic Pressure Step	250 psi [4] 1725k Pa	250 psi [4] 1725k Pa	250 psi [4] 1725k Pa	250 psi [4] 1725k Pa
Resolution	0.02 mpsi 77 dB	0.06 mpsi 86 dB	0.02 mpsi 77 dB	0.06 mpsi 86 dB
Resonant Frequency	≥ 13k Hz	≥ 13k Hz	≥ 13k Hz	≥ 13k Hz
Rise Time (Reflected)	≤ 25 μsec	≤ 25 μsec	≤ 25 μsec	≤ 25 μsec
Low Frequency Response (-5 %)	5 Hz	5 Hz	5 Hz	5 Hz
Non-Linearity	≤ 2 % [2]	≤ 2 % [2]	≤ 2 % [2]	≤ 2 % [2]
Acceleration Sensitivity	≤ 0.0005 psi/g ≤ 0.0035 psi/(m/s ²)	≤ 0.0005 psi/g ≤ 0.0035 psi/(m/s ²)	≤ 0.0005 psi/g ≤ 0.0035 psi/(m/s ²)	≤ 0.0005 psi/g ≤ 0.0035 psi/(m/s ²)
Temperature Range	-100 to +250 °F -73 to +121 °C	-100 to +250 °F -73 to +121 °C	-100 to +250 °F -73 to +121 °C	-100 to +250 °F -73 to +121 °C
Discharge Time Constant (at room temp)	≥ 0.1 sec	≥ 0.1 sec	≥ 0.1 sec	≥ 0.1 sec
Electrical Connector	Integral Cable	10-32 Coaxial Jack	Integral Cable	Integral Cable
Housing Material	304L Stainless Steel	304L Stainless Steel	304L Stainless Steel	304L Stainless Steel
Diaphragm Material	316 Stainless Steel	316 Stainless Steel	316 Stainless Steel	316 Stainless Steel
Sealing	Epoxy	Welded Hermetic	Epoxy	Welded Hermetic
Supplied Accessories				
Adhesive Mounting Ring	(3) 065A66	(3) 065A66	(3) 065A66	(3) 065A66
Sleeve Clamp	061A04	061A04	—	—
English Clamp Nuts	—	—	(1) 060A10, 1/2-20 thd	(1) 060A10, 1/2-20 thd
Metric Clamp Nuts	—	—	(1) 060A24, M14x1.25 thd	(1) 060A24, M14x1.25 thd
Seal Rings	—	—	(3) 160-0242-00 O-ring	(3) 160-0242-00 O-ring
Additional Accessories				
Mating Cable Connectors	EB	EB	EB	EB
Recommended Cables	002 low cost, 003 CE	002 low cost, 003 CE	2 low cost, 003 CE	2 low cost, 003 CE
Additional Versions				
Side Connector	—	—	103B03	103B13
Metric Mount	M103B01	M103B11	M103B02	M103B12
Notes				
[1] For +10 volt output, minimum 24 VDC supply voltage required. Negative 10 volt output may be limited by output bias [2] Zero-based, least-squares, straight line method				

This is a small sample of PCB's ICP® acoustic pressure sensor offering. Refer to PCB's Test & Measurement catalog or search "103" at www.pcb.com.



Series 106B

ICP® for High Intensity, Acoustic Pressure Sensors

Model 106B and 106B50 are high sensitivity, acceleration-compensated, ICP® quartz pressure sensors suitable for measuring intense acoustic phenomena. In fact, the series is widely used for measuring acoustic fields in operating launch vehicles and their associated payloads. The Series 106 family range spans from acoustic pressures of less than 80 dB to several psi. Similar piezoelectric technology is employed in PCB's complete range of hermetically sealed dynamic pressure sensors. These products measure pressure fluctuations from acoustic levels to tens of thousands of psi and frequencies from nearly DC to tens of kHz. Their ability to measure only pressure fluctuations above a specified frequency imposed on large static pressure fields makes them uniquely suited for such applications as combustion instability monitoring.



High Sensitivity, ICP® Acoustic Pressure Sensors

Model Number	106B52	106B50	106B
Measurement Range (± 2 V output)	1 psi 6.89k Pa [1]	5 psi 34.45k Pa	8.3 psi 57.2k Pa
Sensitivity	5000 mV/psi 725 mV/kPa	500 mV/psi 72.5 mV/kPa	300 mV/psi 43.5 mV/psi
Maximum Dynamic Pressure Step	10 psi 68.9k Pa	100 psi 690k Pa	200 psi 1379k Pa
Maximum Static Pressure	50 psi 345k Pa	500 psi 3448k Pa	2 kpsi 13,790k Pa
Resolution	0.02 mpsi 0.00013k Pa	0.07 mpsi 0.00048k Pa	0.1 mpsi 0.00069k Pa
Resonant Frequency	≥ 40 kHz	≥ 40 kHz	≥ 60 kHz
Low Frequency Response (-5 %)	2.5 Hz	0.5 Hz	0.5 Hz
Acceleration Sensitivity	≤ 0.002 psi/g ≤ 0.0014 kPa/(m/s ²)	≤ 0.002 psi/g ≤ 0.0014 kPa/(m/s ²)	≤ 0.002 psi/g ≤ 0.0014 kPa/(m/s ²)
Temperature Range	-65 to +250 °F -54 to +121 °C	-65 to +250 °F -54 to +121 °C	-65 to +250 °F -54 to +121 °C
Discharge Time Constant (at room temp)	≥ 0.2 sec	≥ 1 sec	≥ 1 sec
Electrical Connector	10-32 Coaxial Jack	10-32 Coaxial Jack	10-32 Coaxial Jack
Housing Material	17-4 Stainless Steel	17-4 Stainless Steel	304/304L Stainless Steel
Diaphragm Material	316L Stainless Steel	316L Stainless Steel	316L Stainless Steel
Sealing	Welded Hermetic	Welded Hermetic	Welded Hermetic
Supplied Accessories			
English Clamp Nuts	(1) 060A11, 3/4-16, Acetal	(1) 060A11, 3/4-16, Acetal	(1) 060A12, 9/16-18 thd
Metric Clamp Nuts	(1) 060A13, M20x1.25, Acetal	(1) 060A13, M20x1.25, Acetal	(1) 060A14, M14 x 1.25 thd
Seal Rings	(3) 065A36 Acetal, 0.060 in thk	(3) 065A36 Acetal, 0.060 in thk	(1) 065A37, brass, 0.025 in thk
Additional Accessories			
Pipe Thread Adaptor	062A07, 1/2 NPT	062A07, 1/2 NPT	062A06, 1/2 NPT
English Thread Adaptor	—	—	061A60, 3/4-16 thd
Ground Isolated Adaptor, English Thread	061A65, 1.0-12 thd, Acetal	061A65, 1.0-12 thd, Acetal	061A61, 3/4-16 thd, Acetal
Water Cooled Adaptor	064A07	064A07	064B06
Mating Cable Connectors	EB	EB	EB
Recommended Stock Cables	002 Low Cost, 003 CE	002 Low Cost, 003 CE	002 Low Cost, 003 CE
Notes			
[1] For ± 5 V output			

This is a sample of PCB's Quartz ICP Pressure Sensors. Refer to PCB's Test & Measurement catalog or search "106" at www.pcb.com.



Series 113B

High Frequency, General Purpose Pressure Sensors

PCB® Series 113B dynamic pressure sensors set the standard for extremely fast, micro-second response and a wide amplitude and frequency range that allows them to excel in high-frequency applications where minimum sensor diameter is required. Typical applications include combustion studies, explosive component testing (e.g. detonators, explosive bolts), airbag testing, and measurement of air blast shock waves resulting from explosions.

Features

- Fast rise time $\leq 1 \mu\text{sec}$ from quartz element
- Ultra-high resonant frequency of $\geq 500 \text{ kHz}$
- Frequency-tailored output without the “ringing” characteristic of most other sensors
- Internal acceleration compensation minimizes shock and vibration sensitivity



Series 113B

Series 113B High Frequency, General Purpose Pressure Sensors

Model Number	113B28	113B21	113B26	113B24	113B22	113B23
Measurement Range ($\pm 5 \text{ V}$ output)	50 psi 344.7k Pa	200 psi 1379k Pa	500 psi 3450k Pa	1 kpsi 6895k Pa	5 kpsi 34,475k Pa	10 kpsi 68,950k Pa
Useful Overrange	100 psi [1] 690k Pa [1]	400 psi [1] 2758k Pa [1]	1 kpsi [1] 6895k Pa [1]	2 kpsi [1] 13,790k Pa [1]	10 kpsi [1] 68,950k Pa [1]	—
Sensitivity	100 mV/psi 14.5 mV/kPa	25 mV/psi 3.6 mV/kPa	10 mV/psi 1.45 mV/kPa	5 mV/psi 0.725 mV/kPa	1 mV/psi 0.145 mV/psi	0.5 mV/psi 0.073 mV/kPa
Maximum Pressure	1k psi 6895k Pa	1k psi 6895k Pa	10k psi 68,950k Pa	10k psi 68,950k Pa	15k psi 103,420k Pa	15k psi 103,420k Pa
Resolution	1 mpsi 0.007 kPa [3]	3 mpsi 0.021 kPa [3]	10 mpsi 0.069 kPa [3]	20 mpsi 0.138 kPa [3]	100 mpsi 0.690 kPa [3]	200 mpsi 1.38 kPa [3]
Resonant Frequency	$\geq 500\text{k Hz}$	$\geq 500\text{k Hz}$	$\geq 500\text{k Hz}$	$\geq 500\text{k Hz}$	$\geq 500\text{k Hz}$	$\geq 500\text{k Hz}$
Rise Time (Reflected)	$\leq 1 \mu\text{sec}$	$\leq 1 \mu\text{sec}$	$\leq 1 \mu\text{sec}$	$\leq 1 \mu\text{sec}$	$\leq 1 \mu\text{sec}$	$\leq 1 \mu\text{sec}$
Low Frequency Response (-5 %)	0.5 Hz	0.5 Hz	0.01 Hz	0.005 Hz	0.001 Hz	0.0005 Hz
Non-linearity	$\leq 1 \%$ [2]	$\leq 1 \%$ [2]	$\leq 1 \%$ [2]	$\leq 1 \%$ [2]	$\leq 1 \%$ [2]	$\leq 1 \%$ [2]
Acceleration Sensitivity	$\leq 0.002 \text{ psi/g}$ $\leq 0.0014 \text{ kPa/(m/s}^2\text{)}$	$\leq 0.002 \text{ psi/g}$ $\leq 0.0014 \text{ kPa/(m/s}^2\text{)}$	$\leq 0.002 \text{ psi/g}$ $\leq 0.0014 \text{ kPa/(m/s}^2\text{)}$	$\leq 0.002 \text{ psi/g}$ $\leq 0.0014 \text{ kPa/(m/s}^2\text{)}$	$\leq 0.002 \text{ psi/g}$ $\leq 0.0014 \text{ kPa/(m/s}^2\text{)}$	$\leq 0.002 \text{ psi/g}$ $\leq 0.0014 \text{ kPa/(m/s}^2\text{)}$
Temperature Range	-100 to +275 °F -73 to +135 °C	-100 to +275 °F -73 to +135 °C	-100 to +275 °F -73 to +135 °C	-100 to +275 °F -73 to +135 °C	-100 to +275 °F -73 to +135 °C	-100 to +275 °F -73 to +135 °C
Discharge Time Constant	$\geq 1 \text{ sec}$	$\geq 1 \text{ sec}$	$\geq 50 \text{ sec}$	$\geq 100 \text{ sec}$	$\geq 500 \text{ sec}$	$\geq 1000 \text{ sec}$
Electrical Connector	10-32 Coaxial Jack	10-32 Coaxial Jack	10-32 Coaxial Jack	10-32 Coaxial Jack	10-32 Coaxial Jack	10-32 Coaxial Jack
Housing Material	17-4 Stainless Steel	17-4 Stainless Steel	17-4 Stainless Steel	17-4 Stainless Steel	17-4 Stainless Steel	17-4 Stainless Steel
Diaphragm Material	Invar	Invar	Invar	Invar	Invar	Invar
Sealing	Welded Hermetic	Welded Hermetic	Welded Hermetic	Welded Hermetic	Welded Hermetic	Welded Hermetic

Supplied Accessories

Seal Rings	(3) 065A02 brass, 0.015 in thk (1) 065A05 stainless steel, 0.240 in thk
Clamp Nuts	(1) 060A03 English 5/16-24, (1) 060A05 metric M7

Additional Accessories

Installation Tooling Kits	040A10 (English), 040A11 (Metric)
Mounting Adaptors	061A01 (3/8-24), 061A10 (M10), 062A01 (1/8-NPT), 061A59 (3/8-24 Acetal, Ground Isolated), 064B02 Water Cooled, Flush Mount
Mating Cable Connectors	EB for blast and general purpose applications
Recommended Cables	002 for blast and general purpose applications, 003 for applications that require CE conformance

Additional Versions

	113B38	113B31	113B36	113B34	113B32	113B33
All Invar Material	113B38	113B31	113B36	113B34	113B32	113B33
Low Cost	—	—	111A26	111A24	111A22	111A23
Stainless Diaphragm	S113B28	S113B281	S113B26	S113B24	S113B22	S113B23
Low Cost Stainless Diaphragm	—	—	S111A26	S111A24	S111A22	S111A23

Notes

[1] For +10 volt output, minimum 24 VDC supply voltage required. Negative 10 volt output may be limited by output bias [2] Zero-based, least-squares, straight line method [3] Resolution dependent on range setting and cable length used in charge system

This is a sample of PCB's Pressure Sensor offerings. Refer to PCB's Test & Measurement catalog or search "113" at www.pcb.com.



PCB® Signal Conditioning

Airborne amplifiers



**Single-Channel, Charge Amplifier
Model 495M76**

- 15 mV/pC charge conversion
- ±166 pC input range
- 0.5 Hz to 50 Hz (-5%) frequency response
- 12 VDC power
- -40 to +250 °F (-40 to +121 °C) temperature range
- 1.0H x 2.4W x 2.52D in (25.4H x 61.0W x 64.0D mm)



**Three-Channel, Charge Amplifier
Model 495M77**

- 28 mV/pC charge conversion
- ±89 pC input range
- 0.5 Hz to 50 Hz (-5%) frequency response
- 12 VDC power
- -40 to +250 °F (-40 to +121 °C) temperature range
- 1.0H x 3.5W x 2.0D in (25.4H x 88.9W x 50.8D mm)



**Differential Charge
Series 495B10**

- 2 or 10 mV/pC charge conversion
- ±1250 or ±250 pC input range
- 10 Hz to 10 kHz (-5%) frequency response
- 10 to 30 VDC power
- -13 to +185 °F (-25 to +85 °C) temperature range
- 5.5L x 173W x 1.21H in (139.7L x 42.8W x 30.8H mm)

**Single-Channel, ICP®
Signal Conditioner/Amplifier
Model 495B**

- +180 to +4,500 mV input range
- 1 to 25 adjustable gain
- 3 Hz (-5%) to 2k Hz (-3 dB) frequency response
- 28 VDC power
- -40 to +200 °F (-40 to +93 °C) temperature range
- 2.86L x 1.13W x 0.88H in (72.7L x 28.7W x 22.4H mm)

This product is a controlled item under the International Traffic in Arms Regulations (ITAR), administered by the Office of Defense Trade Controls. Any export of this product from the United States, including any item in which this product may be incorporated, requires appropriate authorization from the U.S. State Department. Diversion contrary to U.S. law is prohibited.

In-line Charge Converters



Model 422E12

- For use with charge mode sensors
- 10 mV/pC gain
- ± 250 pC input range (±2%)
- 5 to 100k Hz frequency response (±5%)
- 3.4L x 0.5D in (85.1L x 12.7D mm)

Model 422E11

- For use with charge mode sensors
- 100 mV/pC gain
- ± 25 pC input range (±2%)
- 5 to 110k Hz frequency response (±5%)
- 3.4L x 0.5D in (85.1L x 12.7D mm)

Model 422E35

- For use with charge sensors that operate at high temperatures
- 1 mV/pC gain
- ± 2500 pC input range (±2%)
- 5 to 100k Hz frequency response (±5%)
- 3.4L x 0.5D in (85.1L x 12.7D mm)

Model 422E36

- For use with charge sensors that operate at high temperatures
- 10 mV/pC gain
- ± 250 pC input range (±2%)
- 5 to 100k Hz frequency response (±5%)
- 3.4L x 0.5D in (85.1L x 12.7D mm)



Model 422M201

- For use with charge sensors using aircraft power
- 1 & 10 mV/pC gain, dual range
- Overrange ± 3 V
- 5 Hz Low frequency response (±5%)
- 100k Hz High frequency response (20 mA)
- 3.75L x 1.25W x 1.25H in (96L x 32W x 32H mm)

Miniature, 3-Channel, ICP®
Signal Conditioner



Model 485M49

- For use with ICP® triaxial accelerometers
- 18-30 VDC supply voltage
- 4.0 (±1) mA DC supply current for ICP® sensor
- 1 to 100k Hz frequency response (±5%)
- 1.45H x 2.90W x 0.70D in (36.8H x 73.7W x 17.8D mm)

Three-Channel, ICP® Signal
Conditioner / Amplifier



Model 495M57

- Input signal +100 to +5000 mV Input range
- 0.5 to 25 adjustable gain
- 0.9 Hz to 100 Hz (-3 dB%) frequency response
- 28 VDC power
- -40 to +200 °F (-40 to +93 °C) temperature range
- 1.0L x 3.5W x 2.0H in (25.4L x 88.9W x 50.8H mm)



This is a sample of PCB's signal conditioning options. Refer to PCB's Test & Measurement catalog or search "signal conditioner" at www.pcb.com.



Cables and Connectors

PCB® builds all of our cables and most of our connectors in our own plant. This ensures quick delivery and quality support. These connectors are particularly appropriate for flight testing. For instance, our 10-32 connectors are rated to 100,000 g's without backing off of the sensor.



Handheld Calibrator

Model 394C06 Handheld Shaker is a small, self-contained, battery powered, vibration exciter specifically designed to conveniently verify accelerometer and vibration system performance. It accepts sensors weighing up to 210 grams and delivers a controlled, 1 g mechanical excitation at 159.2 Hz.



Please see these PCB Piezotronics catalogs for your other Aerospace & Defense applications:

- Ground Test
- Explosive, Gun, & Impact Testing
- Environmental Test
- OEM Capabilities

For our complete line of sensors, see our Test & Measurement Catalog.

AEROSPACE & DEFENSE
A PCB PIEZOTRONICS DIV.

3425 Walden Avenue, Depew, NY 14043-2495 USA

Toll-Free in USA 866-816-8892

Fax 716-684-0987 E-mail aerosales@pcb.com

The Global Leader in Sensors and Instrumentation For All Your Applications



Toll-Free in USA 888-684-0014
E-mail automotivesales@pcb.com



Toll-Free in USA 800-959-4464
E-mail imi@pcb.com



Toll-Free in USA 800-828-8840
E-mail info@pcb.com



Toll-Free in USA 888-258-3222
E-mail sales@larsondavis.com



Toll-Free in USA 800-860-4867
E-mail info@modalshop.com



3425 Walden Avenue, Depew, NY 14043-2495 USA

Toll-Free in USA 866-816-8892

24-hour SensorLineSM 716-684-0001

Fax 716-684-0987 E-mail aerosales@pcb.com

Web Site www.pcb.com

AS9100 CERTIFIED ■ ISO 9001 CERTIFIED ■ A2LA ACCREDITED to ISO 17025

© 2012 PCB Group, Inc. In the interest of constant product improvement, specifications are subject to change without notice. PCB, ICP, Modally Tuned, Spindler, Swiveler and TORKDISC are registered trademarks of PCB Group. SoundTrack LXT, Spark and Blaze are registered trademarks of PCB Piezotronics. SensorLine is a service mark of PCB Group. All other trademarks are property of their respective owners.

AD-FLIGHTTEST-0812

Printed in U.S.A.

The **Aerospace & Defense** division of PCB Piezotronics serves the Turbine Engine, Helicopter Health and Usage Monitoring (HUMS), Ground Vibration Test, Flight Test, Wind Tunnel Test, Fuze/Safe and Arm, Spacecraft and Aerospace Systems design and development communities with sensors and associated signal conditioning for measurement of acceleration (vibration, shock and rigid body); acoustics; pressure; force; strain; and torque. Sensor technologies employed include piezoelectric, piezoresistive (both strain gage and MEMS) and variable capacitive (both MEMS and microphone). Manufacturing operations are certified to AS9100 and ISO 9001, with calibration procedures accredited by A2LA to ISO 17025. Products can be manufactured to meet specific aerospace environmental standards, with program design requirements to meet RTCA-DO-160 and MIL-STD-810, and low outgassing designs available for specific applications.

Visit www.pcb.com to locate your nearest sales office