



**Model 039237-50051/B**

**Rotary Torque Angle Transducer, w/Auto-ID, 50 lbf-ft (68 Nm), 3/8-inch Square Drive, 10-pin PT Receptacle**

**Installation and Operating Manual**

**For assistance with the operation of this product,  
contact the PCB Piezotronics, Inc.**

**Toll-free: 716-684-0001  
24-hour SensorLine: 716-684-0001  
Fax: 716-684-0987  
E-mail: [info@pcb.com](mailto:info@pcb.com)  
Web: [www.pcb.com](http://www.pcb.com)**



## Repair and Maintenance

PCB guarantees Total Customer Satisfaction through its “Lifetime Warranty Plus” on all Platinum Stock Products sold by PCB and through its limited warranties on all other PCB Stock, Standard and Special products. Due to the sophisticated nature of our sensors and associated instrumentation, **field servicing and repair is not recommended and, if attempted, will void the factory warranty.**

Beyond routine calibration and battery replacements where applicable, our products require no user maintenance. Clean electrical connectors, housings, and mounting surfaces with solutions and techniques that will not harm the material of construction. Observe caution when using liquids near devices that are not hermetically sealed. Such devices should only be wiped with a dampened cloth—never saturated or submerged.

In the event that equipment becomes damaged or ceases to operate, our Application Engineers are here to support your troubleshooting efforts 24 hours a day, 7 days a week. Call or email with model and serial number as well as a brief description of the problem.

## Calibration

Routine calibration of sensors and associated instrumentation is necessary to maintain measurement accuracy. We recommend calibrating on an annual basis, after exposure to any extreme environmental influence, or prior to any critical test.

PCB Piezotronics is an ISO-9001 certified company whose calibration services are accredited by A2LA to ISO/IEC 17025, with full traceability to SI through N.I.S.T. In addition to our standard calibration services, we also offer specialized tests, including: sensitivity at elevated or cryogenic temperatures, phase response, extended high or low frequency response, extended range, leak testing, hydrostatic pressure testing, and others. For more information, contact your local PCB Piezotronics distributor, sales representative, or factory customer service representative.

## Returning Equipment

If factory repair is required, our representatives will provide you with a Return Material Authorization (RMA) number, which we use to reference any information you have already provided and expedite the repair process. This number should be clearly marked on the outside of all returned package(s) and on any packing list(s) accompanying the shipment.

## Contact Information

PCB Piezotronics, Inc.  
3425 Walden Ave.  
Depew, NY14043 USA  
Toll-free: (800) 828-8840  
24-hour SensorLine: (716) 684-0001  
General inquiries: [info@pcb.com](mailto:info@pcb.com)  
Repair inquiries: [rma@pcb.com](mailto:rma@pcb.com)

For a complete list of distributors, global offices and sales representatives, visit our website, [www.pcb.com](http://www.pcb.com).

## Safety Considerations

This product is intended for use by qualified personnel who recognize shock hazards and are familiar with the precautions required to avoid injury. While our equipment is designed with user safety in mind, the protection provided by the equipment may be impaired if equipment is used in a manner not specified by this manual.

Discontinue use and contact our 24-Hour Sensorline if:

- Assistance is needed to safely operate equipment
- Damage is visible or suspected
- Equipment fails or malfunctions

For complete equipment ratings, refer to the enclosed specification sheet for your product.

## Definition of Terms and Symbols

The following symbols may be used in this manual:



### DANGER

Indicates an immediate hazardous situation, which, if not avoided, may result in death or serious injury.

**CAUTION**

Refers to hazards that could damage the instrument.

**NOTE**

Indicates tips, recommendations and important information. The notes simplify processes and contain additional information on particular operating steps.

**The following symbols may be found on the equipment described in this manual:**



This symbol on the unit indicates that high voltage may be present. Use standard safety precautions to avoid personal contact with this voltage.



This symbol on the unit indicates that the user should refer to the operating instructions located in the manual.



This symbol indicates safety, earth ground.



PCB工业监视和测量设备 - 中国RoHS2公布表

PCB Industrial Monitoring and Measuring Equipment - China RoHS 2 Disclosure Table

部件名称	有害物质					
	铅 (Pb)	汞 (Hg)	镉 (Cd)	六价铬 (Cr(VI))	多溴联苯 (PBB)	多溴二苯醚 (PBDE)
住房	0	0	0	0	0	0
PCB板	X	0	0	0	0	0
电气连接器	0	0	0	0	0	0
压电晶体	X	0	0	0	0	0
环氧	0	0	0	0	0	0
铁氟龙	0	0	0	0	0	0
电子	0	0	0	0	0	0
厚膜基板	0	0	X	0	0	0
电线	0	0	0	0	0	0
电缆	X	0	0	0	0	0
塑料	0	0	0	0	0	0
焊接	X	0	0	0	0	0
铜合金/黄铜	X	0	0	0	0	0
本表格依据 SJ/T 11364 的规定编制。						
0：表示该有害物质在该部件所有均质材料中的含量均在 GB/T 26572 规定的限量要求以下。						
X：表示该有害物质至少在该部件的某一均质材料中的含量超出 GB/T 26572 规定的限量要求。						
铅是欧洲RoHS指令2011/65/ EU附件三和附件四目前由于允许的豁免。						

CHINA RoHS COMPLIANCE

Component Name	Hazardous Substances					
	Lead (Pb)	Mercury (Hg)	Cadmium (Cd)	Chromium VI Compounds (Cr(VI))	Polybrominated Biphenyls (PBB)	Polybrominated Diphenyl Ethers (PBDE)
Housing	O	O	O	O	O	O
PCB Board	X	O	O	O	O	O
Electrical Connectors	O	O	O	O	O	O
Piezoelectric Crystals	X	O	O	O	O	O
Epoxy	O	O	O	O	O	O
Teflon	O	O	O	O	O	O
Electronics	O	O	O	O	O	O
Thick Film Substrate	O	O	X	O	O	O
Wires	O	O	O	O	O	O
Cables	X	O	O	O	O	O
Plastic	O	O	O	O	O	O
Solder	X	O	O	O	O	O
Copper Alloy/Brass	X	O	O	O	O	O

This table is prepared in accordance with the provisions of SJ/T 11364.

O: Indicates that said hazardous substance contained in all of the homogeneous materials for this part is below the limit requirement of GB/T 26572.

X: Indicates that said hazardous substance contained in at least one of the homogeneous materials for this part is above the limit requirement of GB/T 26572.

Lead is present due to allowed exemption in Annex III or Annex IV of the European RoHS Directive 2011/65/EU.



# Rotary Socket Wrench Torque Transducer

## Installation and Operating Manual



For assistance with the operation of this product, contact:

**RS Technologies**

**Division of PCB Load & Torque, Inc.**

**Toll-Free in USA: 888-684-2894**

**24-hour SensorLine<sup>SM</sup>: 716-684-0001**

**Fax: 248-888-8266**

**E-mail: [rsinfo@pcbloadtorque.com](mailto:rsinfo@pcbloadtorque.com)**



1.0 INTRODUCTION

Rotary Socket Wrench Torque Transducers manufactured by RS Technologies Division of PCB Load & Torque, Inc., are widely used in the fastener assembly market to verify the performance of hand and power torque tools. These strain gage-based transducers are fitted on the output drive of a power tool and measure the torque applied by the tool to the fastener on an actual assembly. This measurement provides important information about tool shut off and can assist in establishing specifications for proper assembly.

When equipped with the optional angle encoder, the rotary torque transducer can measure the angle of fastener rotation which is an important indication of joint integrity. Torque-angle transducers can provide the data to draw torque vs. time or torque vs. angle plots that can help analyze problematic joints and determine appropriate tightening strategies. They are also a key component of a threaded fastener torque tension testing machine. Rotary torque transducers come in a wide range of capacities (from ¼ Nm up to 25,000 Nm) and fit most popular drive sizes.

All models utilize strain gages configured into a Wheatstone Bridge Circuit to produce the primary sensing element. The four-arm Wheatstone Bridge configuration is shown below in **Figure 1**. Also pictured in **Figure 1** is the wiring code for the standard 10-pin PT receptacle.

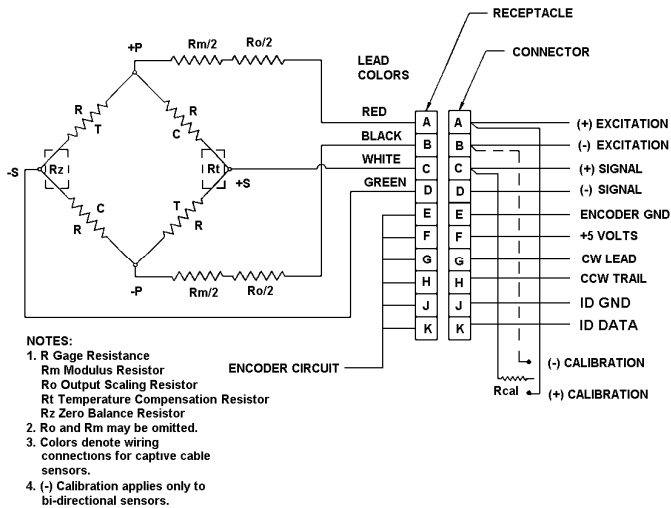

Figure 1 – Rotary Socket Wrench Transducer Wheatstone Bridge & Wiring Code

The gages are bonded to the transducer’s flexure. Typically, a regulated DC or AC excitation is applied between A and B of the bridge. When torque is applied to the transducer, the Wheatstone Bridge becomes unbalanced, producing an output signal voltage between C and D, which is proportional to the applied load. The magnitude of the output signal corresponds

to the deflection of the transducer and therefore the applied load. This configuration allows for temperature and pressure compensation, as well as cancellation of signals caused by forces not directly applied to the axis of the applied load. Output is typically expressed in units of millivolt per volt of excitation. Optional data collectors and signal conditioners are available from RS Technologies and PCB Load & Torque.

There are two basic types of rotary socket wrench torque transducers: one measures torque and angle of rotation, the other measures only torque. They are both supplied with an Auto-ID chip that can be used by data collectors provided by RS Technologies to simplify setup and calibration.

Specifications

Torque

- Output at Rated Capacity ... 2 mV/V  $\pm 0.25\%$  FS
- Shunt Calibration ... Matched 2.000mV/V  $\pm 0.25\%$  with 43.575 kOhm precision resistor
- Interchangeability ... Matched for mV/V and shunt calibration  $\pm 0.3\%$  FS
- Nonlinearity ...  $\pm 0.25\%$  FS
- Hysteresis ...  $\pm 0.25\%$  FS
- Recommended Excitation ... 10 VDC or AC RMS
- Bridge Resistance ... 350 Ohms
- Compensated Temperature Range ... +70to +150°F
- Useable Temp Range ... 0 to +200°F

General

- Receptacle ... Bendix PT02H-12-10P
- Mating Connector ... Bendix PT06A-12-10S(SR)
- Dimensions ... Refer to Standard Torque Sensor Literature

Angle

- Magnetic Encoder ... 360 Poles (540 poles on 3/4-inch drives, 720 poles on 1-inch and 1 ½-inch drives, 900 poles on 2 ½-inch drives)
- Output ... A-B Track 90 degrees phase difference flat over operating speed range
- Resolution w/Quadrature ... ¼ degree (3/16 degree on 3/4-inch drives, 1/8 degree on 1-inch drives, 1/10 degree on 2 ½-inch drives)
- Output Voltage ... High 5V, Low 0.5V
- Power Required ... 5 VDC @ 120 mA max.

Recommended Max RPM

- ¼-in Drive ... 5000
- 3/8-in Drive ... 2500
- ½-inch Drive ... 2500
- ¾-in Drive ... 2000
- 1-in Drive ... 1000
- 1 ½-in Drive ... 750
- 2 ½-in Drive ... 500

**Capacities**

The capacities of the torque-only transducers are listed in the table below.

PART NO.	DRIVE SIZE	CAPACITY
039030-50002	¼-inch Hex Drive	32 oz-in (0.23 Nm)
039030-50021	¼-inch Hex Drive	20 lb-in (2.30 Nm)
039025-50051	¼-inch Square Drive	50 lb-in (5.65 Nm)
039030-50101	¼-inch Hex Drive	100 lb-in (11.3 Nm)
039025-50101	¼-inch Square Drive	100 lb-in (11.3 Nm)
039037-50022	⅜-inch Square Drive	200 lb-in (22.7 Nm)
039037-50051	⅜-inch Square Drive	50 lb-ft (67.8 Nm)
039050-50101	½-inch Square Drive	100 lb-ft (135.6 Nm)
039050-51201	½-inch Square Drive	148 lb-ft (200 Nm)
039075-50301	¾-inch Square Drive	300 lb-ft (407 Nm)
039075-51501	¾-inch Square Drive	368 lb-ft (500 Nm)
039075-53601	¾-inch Square Drive	600 lb-ft (814 Nm)
039001-53102	1-inch Square Drive	1000 lb-ft (1356 Nm)
039001-01302	1-inch Square Drive	2213 lb-ft (3000 Nm)
039001-53033	1-inch Square Drive	3000 lb-ft (4068 Nm)
039001-01103	1 ½-in Square Drive	7350 lb-ft (10 000 Nm)
039025-00183	2 ½-in Square Drive	18 000 lb-ft (24 408 Nm)

The capacities for the torque-angle transducers are listed below.

PART NO.	DESCRIPTION	CAPACITY
039230-50002	¼-inch Hex Drive	32 oz-in (0.23 Nm)
039230-50021	¼-inch Hex Drive	20 lb-in (2.30 Nm)
039230-50101	¼-inch Hex Drive	100 lb-in (11.3 Nm)
039225-50101	¼-inch Square Drive	100 lb-in (11.3 Nm)
039237-50022	3/8-inch Square Drive	200 lb-in (22.7 Nm)
039237-50051	3/8-inch Square Drive	50 lb-ft (67.8 Nm)
039250-50101	½-inch Square Drive	100 lb-ft (135.6 Nm)
039250-51201	½-inch Square Drive	148 lb-ft (200 Nm)
039275-50301	¾-inch Square Drive	300 lb-ft (407 Nm)
039275-51501	¾-inch Square Drive	368 lb-ft (500 Nm)
039275-53601	¾-inch Square Drive	600 lb-ft (814 Nm)
039201-53102	1-inch Square Drive	1000 lb-ft (1356 Nm)
039201-01302	1-inch Square Drive	2213 lb-ft (3000 Nm)
039201-53302	1-inch Square Drive	3000 lb-ft (4068 Nm)
039301-01103	1 ½-in Square Drive	7360 lb-ft (10 000 Nm)
039625-00183	2 ½-in Square Drive	18 000 lb-ft (24 408 Nm)

**2.0 SAFETY INFORMATION**

Applied loads must be limited to 100% of the rated capacity. Application of loads exceeding rated capacity can lead to damage of the transducer and potential injury to the operator. Therefore, always use care in applying torque to fasteners being audited or tightened failure. Always observe standard plant safety procedures for operation of pneumatic and electric power tools. Operators should always observe standard shop safety requirements, such as wearing steel-toed shoes, safety glasses, etc.

**3.0 MECHANICAL INSTALLATION**

Mechanical installation consists of attaching the proper sized socket or drive fitting to the output end of the transducer. This socket or drive will be lined up with the fastener being tightened. The input end of the transducer is fitted onto the output drive of the tool. If using a torque-angle transducer, secure the housing so that it will not rotate during operation.

**NOTE:** For square drive units, the input end is the female drive; the output end is the male square drive. For hex drive units, the input end is the male drive; the output end is the female hex drive.

**4.0 ELECTRICAL INSTALLATION**

The socket wrench torque transducer is connected to a data collector or signal conditioner via the 10-pin PT receptacle located on the top of the housing. Cable assemblies for RS Technologies and other instruments are available through RS Technologies Division of PCB Load & Torque, Inc.

Connect one end of the cable to the transducer receptacle and the other end to the data collector/signal conditioner. Make sure to completely tighten the cable connector to both the transducer and the instrument.

**5.0 POLARITY**

Clockwise torque on rotary torque transducers produces a positive-going signal output. Counterclockwise torque produces a negative-going signal output. Most data collectors provide a CW/CCW adjustment to ensure correct readings.



## 6.0 SHUNT CALIBRATION

Shunt calibration is a practical method for providing field calibration of data collectors and strain gage transducers such as rotary socket wrench transducers. This provides assurance of obtaining accurate readings without having to apply known, traceable, physical input loads to the transducer, which may be impractical in an assembly line or out in the field.

Shunt calibration simulates the mechanical input to a transducer by unbalancing the bridge with a fixed resistor placed across, or in parallel with, one leg of the bridge. For clockwise shunt calibration, or +CAL, the shunt resistor ( $R_{CAL}$ ) is shunted across the +Excitation (A) and +Signal (C) leg of the bridge. For counterclockwise shunt calibration, or -CAL, the shunt resistor ( $R_{CAL}$ ) is shunted across the -Excitation (BD) and +Signal (C) leg of the bridge. See **Figure 1** for shunt resistor locations in the Wheatstone Bridge circuit utilized by rotary socket wrench torque transducers.

The rotary socket wrench transducer provided by RS Technologies Division of PCB Load & Torque Inc. comes with a calibration certificate. On the first page of this certificate you will find a calibration value in engineering units that is associated with a resistor of a specified impedance. This resistor can be installed on the data collector and used when matching up the instrument to the transducer. Follow the instructions provided with the data collector for complete details on shunt calibration procedures.

### Basic Shunt Calibration Procedure

The following procedure outlines the basic routine of shunt calibration. The actual calibration procedure performed by your data collector may be automated and will differ. Consult the data collector instruction manual for further details.

1. Connect the rotary socket wrench transducer to the data collector and allow adequate time for the system to stabilize. 2 to 5 minutes is recommended.
2. With no load on the transducer, adjust the data collector zero controls for to read zero (0).
3. Shunt the calibration resistor between the desired excitation and signal leads of the Wheatstone Bridge, as described in Section 6.0.
4. Adjust the data collector's gain or span controls as required to obtain an electrical output signal and/or numeric display that represents the simulated calibration load as indicated on the calibration certificate.
5. Remove the shunt resistor and adjust the zero if necessary.
6. If a significant zero adjustment is required, repeat Steps 2-5.

## 7.0 OPERATION

### Typical Rotary Socket Wrench Transducer System Configurations

Operation requires the connection of the transducer to a readout device, data collector, or signal conditioner. Readout instruments, data collectors, and suitable cable assemblies are available from RS Technologies Division of PCB Load & Torque, Inc.

### Operation with a Data Collector or Readout Device

The span and zero of the instrument must be set before the rotary socket wrench transducer system can be used. The span can be set using the shunt calibration value and resistor supplied by the manufacturer, or by a deadweight torque calibrator. Refer to the shunt calibration information in the instruction manual of the instrument for proper setup information.

### Rotary Socket Wrench Transducer Operation Guidelines

Rotary Socket Wrench Transducers are designed for use in measuring the torque output of electric and pneumatic fastener assembly tools. They are also used for threaded fastener testing and trouble-shooting. However, they have been used in many different rotating torque applications. The guidelines below provide some tips that will ensure proper operation and satisfactory results.

- Although the ideal operating range for rotary torque transducers is 60 to 80% of rated capacity, the rotary socket wrench torque transducers can be used between 10 and 100% of rated capacity. This is largely because the first load point for a calibration is typically at the 10% mark but also that the output signal below 10% is often too low to provide adequate resolution by the readout instrument.
- The rotary torque socket wrench transducer has an overload capability of 150% of rated capacity. This provides a safety margin in the event of an accidental overload. It is not recommended that the transducer be used to measure loads at or above 110% of rated capacity on a regular basis.
- Keep the transducer in line with the axial orientation of the fastener. This will help to avoid side loads. Excessive side loads, such as those that may occur when testing large or heavy right-angle power tools, can cause inaccurate readings or even damage the transducer.
- Ensure that both input and output drives of the transducer are fully engaged. Partial engagement may damage the transducer.
- Hex drive transducers come with a spring loaded knurled ring that retracts to permit installation and removal of the

drive bit. Make sure that both ends are fully engaged before use.

- When it's necessary to use a drive adapter, use as few as possible to avoid side loads.
- When using a transducer with an angle encoder, make sure that the housing is held secure to ensure best angle measurement accuracy.
- Rotary socket wrench torque transducers are good for use with standard pneumatic tools, impulse tools, and electric power tools. Do NOT use with "impact" pneumatic tools.

**8.0 TROUBLESHOOTING**

When having difficulty operating the rotary socket wrench transducer, refer to the following checklist.

**No output**

- ✓No power
- ✓Loose or dirty connections
- ✓Open circuit or short
- ✓Faulty or improper wiring
- ✓No torque applied

**Erratic or Improper Readings**

- ✓Excitation voltage drift
- ✓Electrical noise
- ✓Loose fixturing
- ✓Open circuit or short
- ✓Improper load applied
- ✓Cable too long

**Blinking Display**

- ✓Overload condition
- ✓Open circuit

**Zero Balance**

- ✓Load applied to transducer
- ✓Overloaded or side-loaded transducer
- ✓Open circuit
- ✓Improper electrical connections

**Zero Shift**

- ✓Fixture preload
- ✓Faulty or improper wiring
- ✓Improper zero taken

**Zero Drift**

- ✓Unconditioned power supply
- ✓Open circuit or short
- ✓Loose wiring
- ✓RFI/EMI interface
- ✓Temperature change

**Damaged or Deformed Equipment**

- ✓Improper use

**Error Analysis**

PCB Load & Torque, Inc. typically supplies accuracy information on its products in the form of individual errors (see specification sheet). For rotary socket wrench transducers they are: Non-Linearity, Hysteresis, and Non-Repeatability.

The customer can combine these individual errors to establish the maximum possible error for the measurement or just examine the applicable individual error. If the transducer is used for increasing torque measurement only, ignore the Hysteresis error. If the torque measurement is near the full rated capacity, the linearity error can be ignored. If the capability exists to correct the data through linearization-fit or a look-up-table, the error in the measurement can be minimized. A sophisticated user can get rid of all the errors except for the non-repeatability error in the measurement.

If problems persist, contact PCB Load & Torque for technical assistance.

**9.0 MAINTENANCE**

The rotary socket wrench transducers provided by RS Technologies Division of PCB Load & Torque Inc. are made of durable materials, and are intended for industrial use. However, routine maintenance, such as cleaning of electrical connectors, housings, and square drives with solutions and techniques that will not harm the physical material of construction is acceptable. The rotary socket wrench transducers should only be wiped with a damp cloth and never submerged or have liquids poured on them.

**NOTE:** There are no user-serviceable components in rotary socket wrench torque transducers provided by RS Technologies division of PCB Load & Torque Inc. Removing the cover on the unit will void the warranty.

###

*MANUAL NUMBER: 51678  
MANUAL REVISION: NR  
ECN NUMBER: 38209*

Model Number <b>039237-50051/B</b>	<b>ROTARY TORQUE, W/ENCODER AND AUTO ID</b>	Revision: NR ECN #: 47364
---------------------------------------	---	------------------------------

	<u>ENGLISH</u>	<u>SI</u>	
<b>Performance</b>			
Measurement Range(Full Scale Capacity)	50 lbf-ft	68 Nm	
Sensitivity(output at rated capacity)	2.0 mV/V	2.0 mV/V	[7]
Non-Linearity	≤ 0.25 % FS	≤ 0.25 % FS	[2]
Hysteresis	≤ 0.25 % FS	≤ 0.25 % FS	[2]
Non-Repeatability	≤ 0.05 % FS	≤ 0.05 % FS	[2]
Interchangeability	≤ 0.30 % FS	≤ 0.30 % FS	[8][2]
<b>Environmental</b>			
Overload Limit	75 lbf-ft	101 Nm	
Temperature Range(Operating)	0 to +200 °F	-18 to +93 °C	
Temperature Range(Compensated)	+70 to +150 °F	+21 to +66 °C	
Temperature Effect on Output(Maximum)	± 0.002 %Reading/°F	± 0.0018 %Reading/°C	[6]
Temperature Effect on Zero Balance(Maximum)	± 0.002 %FS/°F	± 0.0018 %FS/°C	[6]
<b>Electrical</b>			
Bridge Resistance	350 Ohm	350 Ohm	
Excitation Voltage	10 VDC	10 VDC	[1]
Insulation Resistance	≥ 5 GOhm	≥ 5 GOhm	
Zero Balance	≤ 2 % FS	≤ 2 % FS	[2]
Counts Per Revolution	1472	1472	[3]
Resolution w/ Quadrature	1/4 °	1/4 °	[3]
Output Voltage	High 5V to Low 0.5V	High 5V to Low 0.5V	[3]
Power Required(maximum)	5 VDC @ 120mA	5 VDC @ 120mA	[3]
Magnetic Encoder(Poles)	360	360	
Magnetic Encoder(Output)	See Note	See Note	[4][3]
Shunt Calibration	≤ 0.25 % FS	≤ 0.25 % FS	[5][2]
Auto ID	TTL Proprietary	TTL Proprietary	
<b>Physical</b>			
Size (Shaft Length x Housing Length x Housing Height)	3.23 in x 2.30 in x 2.00 in	82.0 mm x 58.4 mm x 50.8 mm	[9]
Weight	.85 lb	386 gm	
Mounting	3/8 inch Sq Drive	9.52 mm Sq Drive	[10]
Sensing Element	Strain Gage	Strain Gage	
Housing Material	Aluminum	Aluminum	
Shaft Material	Steel	Steel	
Electrical Connector	PT02H-12-10P	PT02H-12-10P	
Maximum Speed	2500 RPM	2500 RPM	

**OPTIONAL VERSIONS**

Optional versions have identical specifications and accessories as listed for the standard model except where noted below. More than one option may be used.

**NOTES:**

[1] Calibrated at 10 VDC, usable 5 to 20 VDC or VAC RMS.  
 [2] FS - Full Scale.  
 [3] Magnetic Encoder Specifications.  
 [4] A-B Track 90° Phase Difference, Flat Over Operating Speed  
 [5] Matched with 43.575 kOhm Precision Resistor.  
 [6] Over compensated temperature range.  
 [7] Matched to ±0.25% F.S.  
 [8] Matched for mV/V and shunt calibration.  
 [9] See Outline Drawing LT38037 for Complete Dimensions  
 [10] Per ANSI B107.4 Specifications  
 [11] See PCB Declaration of Conformance PS119 for details.

**SUPPLIED ACCESSORIES:**  
 Model 7122R-04352A PRECISION CAL RESISTOR 43.575 kOhm

**OPTIONAL ACCESSORIES:**  
 Model 080920-01000 Model 920 Portable Digital Peak Meter for torque, torque-angle or load measurement; Click-Wrench calc feature, w/battery charger, instruction manual & shoulder strap  
 Model 080962-01000 MODEL 962 DATA RECORDER  
 Model 097000-34445 INTERCONNECT CABLE  
 Model 4242R-000630 MATING CONNECTOR PT06A-12-10S(SR)

Entered: LK	Engineer: PE	Sales: DM	Approved: JSD	Spec Number:
Date: 10/31/2017	Date: 10/31/2017	Date: 10/31/2017	Date: 10/31/2017	<b>68204</b>



All specifications are at room temperature unless otherwise specified.  
 In the interest of constant product improvement, we reserve the right to change specifications without notice.



**PCB Load & Torque**  
 A Division of PCB Piezotronics  
 24350 Indopex Circle  
 Farmington Hills, MI 48335  
 UNITED STATES  
 Phone: 866-684-7107  
 E-Mail: LTSales@pcb.com  
 Web site: www.pcb.com/LoadAndTorque

LT38037

PCB Load & Torque Inc. claims proprietary rights in the information disclosed hereon. Neither it nor any reproduction thereof will be disclosed to others without the written consent of PCB Load and Torque Inc.

REVISIONS		
REV	DESCRIPTION	ECO
A	UPDATED DIM'S AND WIRING CODE - 06.21.17, PTE	46925

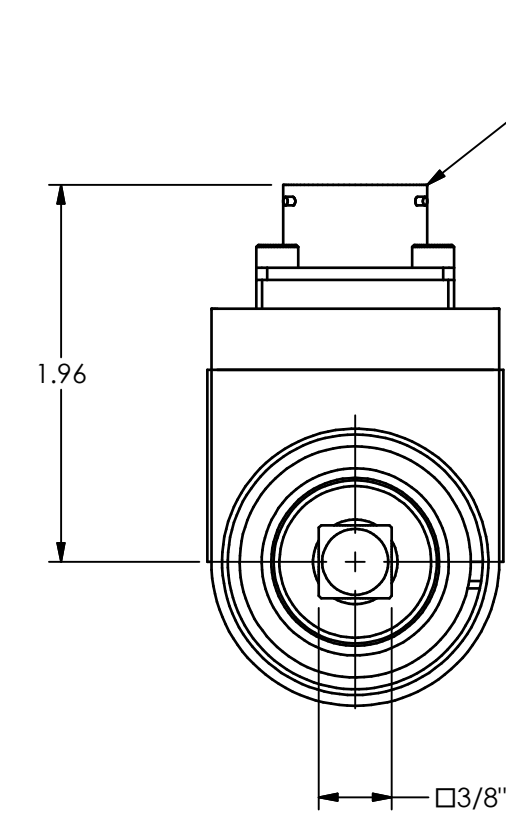
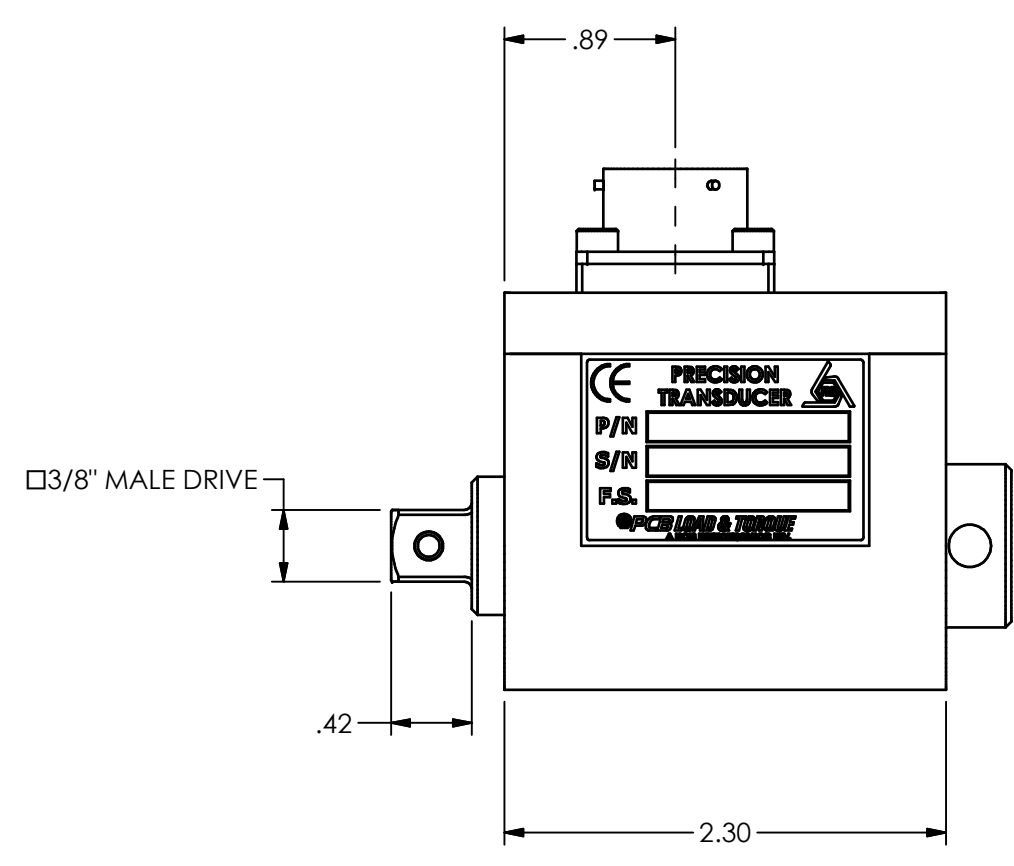
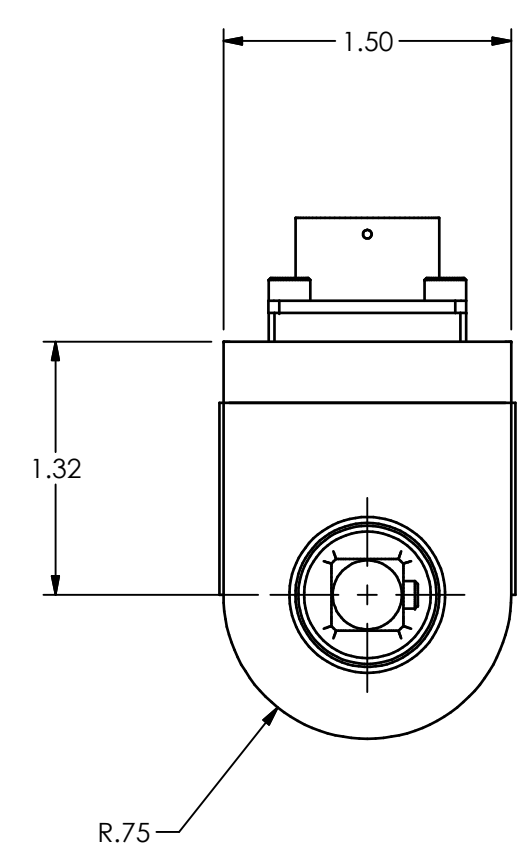
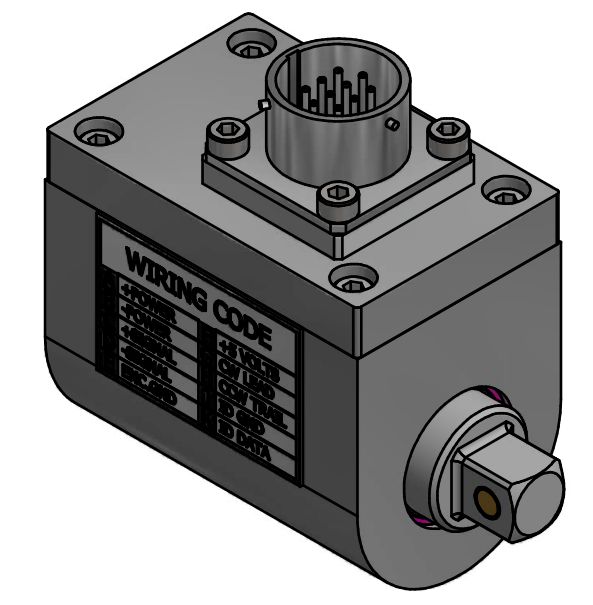
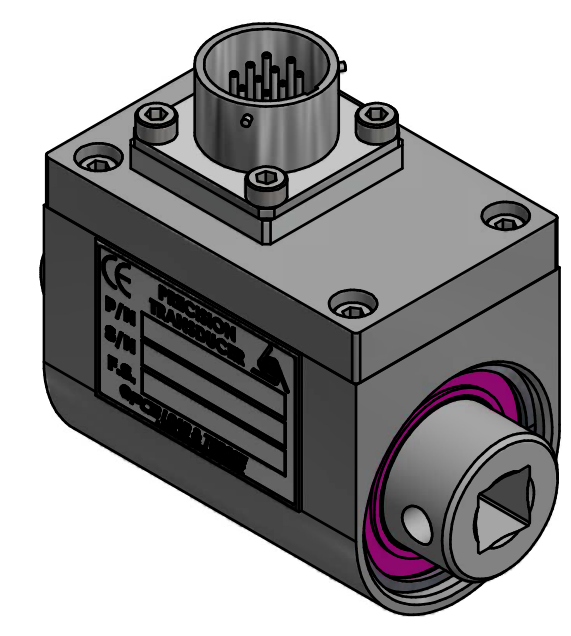
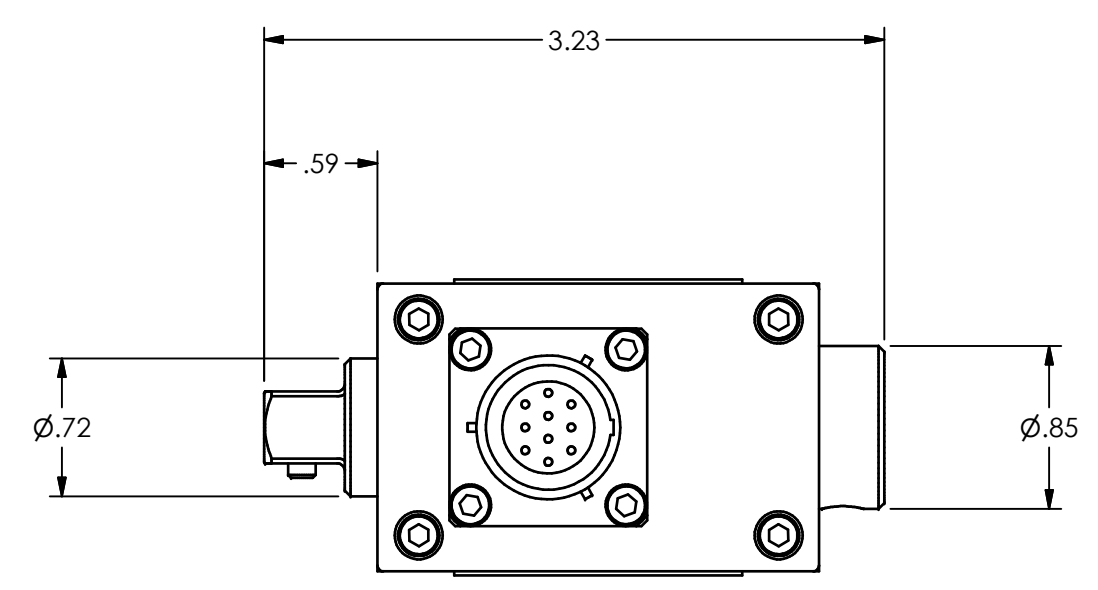

PUSH/TURN RECEPTACLE  
(BENDIX PT02H-12-10P OR EQUIV.)  
WIRING CODE:  
9037 SERIES      9237 SERIES  
PIN A +POWER    PIN A +POWER  
PIN B -POWER    PIN B -POWER  
PIN C +SIGNAL    PIN C +SIGNAL  
PIN D -SIGNAL    PIN D -SIGNAL  
PIN E N/C        PIN E ENCODER GRD  
PIN F N/C        PIN F +5V  
PIN G N/C        PIN G CW LEAD  
PIN H N/C        PIN H CCW TRAIL  
PIN J ID GRD     PIN J ID GRD  
PIN K ID DATA   PIN K ID DATA

UNLESS OTHERWISE SPECIFIED TOLERANCES ARE:		DRAWN	CHECKED	ENGINEER	 24350 Indoplex Circle, Farmington Hills, MI 48335 (716) 684-0001 E-MAIL: lti@pcbloadtorque.com DWG. NO. <b>LT38037</b> SCALE: FULL SHEET 1 OF 1			
DIMENSIONS IN INCHES	DIMENSIONS IN MILLIMETERS [IN BRACKETS]	PTE	3/22/12	JAM		3/22/12	PTE	2/28/12
DECIMALS XX ±.01 XXX ±.005	DECIMALS X ± 0.3 XX ± 0.13	TITLE OUTLINE DRAWING ROTARY TORQUE 3/8" SQ DRIVE, 10 PIN						
ANGLES ± .5 DEGREES	ANGLES ± .5 DEGREES	FILLETS AND RADII .015 MAX						
FILLETS AND RADII 0.38 MAX								