



Model 064B02

**Water-cooled adaptor, sensor flush mount, 1/2-20 thd, 1.0" hex (for Series
Installation and Operating Manual**

**For assistance with the operation of this product,
contact PCB Piezotronics, Inc.**

**Toll-free: 800-828-8840
24-hour SensorLine: 716-684-0001
Fax: 716-684-0987
E-mail: info@pcb.com
Web: www.pcb.com**



Repair and Maintenance

PCB guarantees Total Customer Satisfaction through its “Lifetime Warranty Plus” on all Platinum Stock Products sold by PCB and through its limited warranties on all other PCB Stock, Standard and Special products. Due to the sophisticated nature of our sensors and associated instrumentation, **field servicing and repair is not recommended and, if attempted, will void the factory warranty.**

Beyond routine calibration and battery replacements where applicable, our products require no user maintenance. Clean electrical connectors, housings, and mounting surfaces with solutions and techniques that will not harm the material of construction. Observe caution when using liquids near devices that are not hermetically sealed. Such devices should only be wiped with a dampened cloth—never saturated or submerged.

In the event that equipment becomes damaged or ceases to operate, our Application Engineers are here to support your troubleshooting efforts 24 hours a day, 7 days a week. Call or email with model and serial number as well as a brief description of the problem.

Calibration

Routine calibration of sensors and associated instrumentation is necessary to maintain measurement accuracy. We recommend calibrating on an annual basis, after exposure to any extreme environmental influence, or prior to any critical test.

PCB Piezotronics is an ISO-9001 certified company whose calibration services are accredited by A2LA to ISO/IEC 17025, with full traceability to SI through N.I.S.T. In addition to our standard calibration services, we also offer specialized tests, including: sensitivity at elevated or cryogenic temperatures, phase response, extended high or low frequency response, extended range, leak testing, hydrostatic pressure testing, and others. For more information, contact your local PCB Piezotronics distributor, sales representative, or factory customer service representative.

Returning Equipment

If factory repair is required, our representatives will provide you with a Return Material Authorization (RMA) number, which we use to reference any information you have already provided and expedite the repair process. This number should be clearly marked on the outside of all returned package(s) and on any packing list(s) accompanying the shipment.

Contact Information

PCB Piezotronics, Inc.
3425 Walden Ave.
Depew, NY14043 USA
Toll-free: (800) 828-8840
24-hour SensorLine: (716) 684-0001
General inquiries: info@pcb.com
Repair inquiries: rma@pcb.com

For a complete list of distributors, global offices and sales representatives, visit our website, www.pcb.com.

Safety Considerations

This product is intended for use by qualified personnel who recognize shock hazards and are familiar with the precautions required to avoid injury. While our equipment is designed with user safety in mind, the protection provided by the equipment may be impaired if equipment is used in a manner not specified by this manual.

Discontinue use and contact our 24-Hour Sensorline if:

- Assistance is needed to safely operate equipment
- Damage is visible or suspected
- Equipment fails or malfunctions

For complete equipment ratings, refer to the enclosed specification sheet for your product.

Definition of Terms and Symbols

The following symbols may be used in this manual:



DANGER

Indicates an immediate hazardous situation, which, if not avoided, may result in death or serious injury.

**CAUTION**

Refers to hazards that could damage the instrument.

**NOTE**

Indicates tips, recommendations and important information. The notes simplify processes and contain additional information on particular operating steps.

The following symbols may be found on the equipment described in this manual:



This symbol on the unit indicates that high voltage may be present. Use standard safety precautions to avoid personal contact with this voltage.



This symbol on the unit indicates that the user should refer to the operating instructions located in the manual.



This symbol indicates safety, earth ground.



PCB工业监视和测量设备 - 中国RoHS2公布表

PCB Industrial Monitoring and Measuring Equipment - China RoHS 2 Disclosure Table

部件名称	有害物质					
	铅 (Pb)	汞 (Hg)	镉 (Cd)	六价铬 (Cr(VI))	多溴联苯 (PBB)	多溴二苯醚 (PBDE)
住房	0	0	0	0	0	0
PCB板	X	0	0	0	0	0
电气连接器	0	0	0	0	0	0
压电晶体	X	0	0	0	0	0
环氧	0	0	0	0	0	0
铁氟龙	0	0	0	0	0	0
电子	0	0	0	0	0	0
厚膜基板	0	0	X	0	0	0
电线	0	0	0	0	0	0
电缆	X	0	0	0	0	0
塑料	0	0	0	0	0	0
焊接	X	0	0	0	0	0
铜合金/黄铜	X	0	0	0	0	0
本表格依据 SJ/T 11364 的规定编制。						
0：表示该有害物质在该部件所有均质材料中的含量均在 GB/T 26572 规定的限量要求以下。						
X：表示该有害物质至少在该部件的某一均质材料中的含量超出 GB/T 26572 规定的限量要求。						
铅是欧洲RoHS指令2011/65/ EU附件三和附件四目前由于允许的豁免。						

CHINA RoHS COMPLIANCE

Component Name	Hazardous Substances					
	Lead (Pb)	Mercury (Hg)	Cadmium (Cd)	Chromium VI Compounds (Cr(VI))	Polybrominated Biphenyls (PBB)	Polybrominated Diphenyl Ethers (PBDE)
Housing	O	O	O	O	O	O
PCB Board	X	O	O	O	O	O
Electrical Connectors	O	O	O	O	O	O
Piezoelectric Crystals	X	O	O	O	O	O
Epoxy	O	O	O	O	O	O
Teflon	O	O	O	O	O	O
Electronics	O	O	O	O	O	O
Thick Film Substrate	O	O	X	O	O	O
Wires	O	O	O	O	O	O
Cables	X	O	O	O	O	O
Plastic	O	O	O	O	O	O
Solder	X	O	O	O	O	O
Copper Alloy/Brass	X	O	O	O	O	O

This table is prepared in accordance with the provisions of SJ/T 11364.

O: Indicates that said hazardous substance contained in all of the homogeneous materials for this part is below the limit requirement of GB/T 26572.

X: Indicates that said hazardous substance contained in at least one of the homogeneous materials for this part is above the limit requirement of GB/T 26572.

Lead is present due to allowed exemption in Annex III or Annex IV of the European RoHS Directive 2011/65/EU.

1.0 DESCRIPTION

Various probe style charge or voltage mode quartz pressure sensors can be installed in the series 064 water-cooled adaptors for high temperature:

- combustion pressure measurements on jet and I.C. engines
- pulsation measurements on exhaust manifold and catalytic converters

Caution: Do not use series 064 adaptors for rocket motor measurements. Water jackets with ceramic Rokide® coated surfaces and ruggedized heliarc welded water tubes with AN fittings are required to withstand the rocket motor thermal and vibration environment.

NOTE: Use flexible rubber or plastic tubing **ONLY**. Use of metal tubing and fittings will damage the tubes on the water-cooled adaptor.

2.0 INSTALLATION AND OPERATION

Install the probe style sensor into the water-cooled adaptor and tighten the clamp nut to the proper installation torque of the sensor. Screw the water-cooled adaptor into the mounting port of the test vessel. Connect the electrical cable to the sensor.

Connect waterline to adaptor using standard flexible plastic tubing (Tygon® or equivalent) and cable clamps. Normal waterline pressures of 40 to 60 psi have proven satisfactory in most applications. It is not recommended to exceed 60 psi.

Caution: Do not solder silver metal tubes to the water-cooled adaptor. Heat from soldering can loosen the tubes and cause water leaks. Use of rigid waterline tubes may also cause the water tubes to fatigue due to excessive strain caused by vibration.

If AN fittings or use of rigid tubing is required, please contact your PCB factory applications engineer for details.

LEAVE SENSOR WATER COOLING ON FOR A FEW MINUTES AFTER ENGINE IS SHUT DOWN TO PREVENT HEAT SOAK DAMAGE.

PCB Piezotronics Inc. claims proprietary rights in the information disclosed hereon. Neither it nor any reproduction thereof will be disclosed to others without the written consent of PCB Piezotronics Inc.

REVISIONS

REV	DESCRIPTION	ECN	APP'D
A	UPDATE EXTENDER	15984	DM 9/02
B	ADD FIELD NOTE 5	27903	DM 1/08

7586

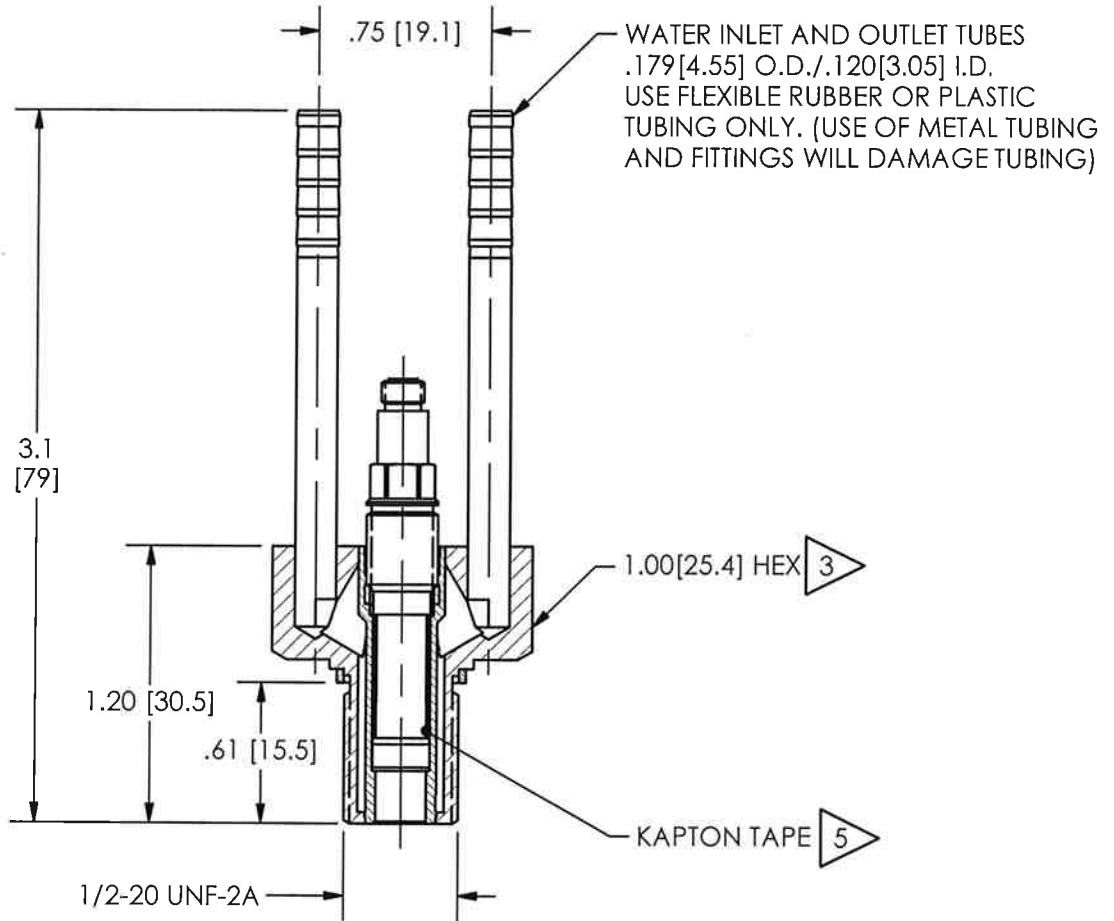

MOUNTING HOLE PREPARATION

- 1 Ø.453 [11.51] THRU
- 2 LØ.562 [14.28] X .050 [1.27] ▽
- 1/2-20 UNF-2B THRU

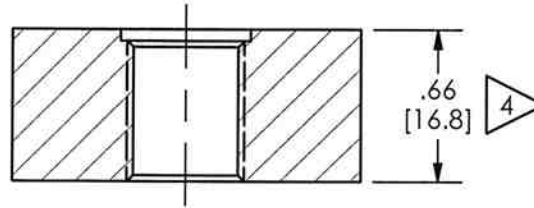

5 ONLY SUPPLIED WITH OFF GROUND OPTION.

4 INSTALLATION FOR WALL THICKNESS OF .66 [16.8]. LØ.1.325 [33.65] FOR THICKER WALLS TO CLEAR 1.00 [25.4] HEX.

3 RECOMMENDED MOUNTING TORQUE ON 1.00 [25.4] HEX: 10-15 FT LBS [14-20 Nm]

2 SEAL SURFACE SHOULD BE FLAT AND FREE OF TOOL MARKS TO WITHIN .001 [.03] TIR WITH A MIN 63 [1.6] ✓ FOR BEST RESULTS.

1 THESE DIAMETERS TO BE CONCENTRIC TO WITHIN .001 [.03] TIR.

UNLESS OTHERWISE SPECIFIED TOLERANCES ARE:

DIMENSIONS IN INCHES

DECIMALS XX ± .01
XXX ± .005

ANGLES ± 2 DEGREES

DIMENSIONS IN MILLIMETERS [IN BRACKETS]

DECIMALS X ± 0.3
XX ± 0.13

ANGLES ± 2 DEGREES

FILLETS AND RADII .003 - .005

FILLETS AND RADII [0.07 - 0.13]

DRAWN	ECB	1/3/08	MFG	PRR	1/3/08
CHK'D	DM	1/3/08	ENGR	RF	1/3/08
APP'D	NJL	1/3/08	SALES	DPC	1/3/08

TITLE

INSTALLATION DRAWING
MODEL 064B02 FLUSH MOUNTED
WATER COOLED ADAPTOR

PCB PIEZOTRONICS INC

3425 WALDEN AVE. DEPEW, NY 14043
(716) 684-0001 E-MAIL: sales@pcb.com

CODE IDENT. NO. 52681	DWG. NO. 7586
-----------------------	---------------

SCALE: FULL SHEET 1 OF 2

PCB Piezotronics Inc. claims proprietary rights in the information disclosed hereon. Neither it nor any reproduction thereof will be disclosed to others without the written consent of PCB Piezotronics Inc.

REVISIONS

REV	DESCRIPTION	ECN	APP'D
	- SEE SHEET ONE -		DM 1/08

7586

MODEL 060A03
CLAMP NUT
.250[6.35] HEX
5/16-24 UNF-2A THREAD
(NOT SUPPLIED)

MODEL 070A04
CONNECTOR EXTENDER
10-32 UNF-2A THREAD
(SUPPLIED)

MODEL 069A02
SPACER SLEEVE
.532[13.51] LONG
(SUPPLIED)

MODEL 065A08
SEAL
.027[.69] THICK

SENSOR
MODEL 111A, 112A, 113A SERIES
(NOT SUPPLIED)

MODEL 065A02
SEAL
.015[.38] THICK
(NOT SUPPLIED)

MODEL 065A22
SEAL
.015[.38] THICK

ADAPTOR
1.00[25.4] HEX
1/2-20 UNF-2A THREAD
(SUPPLIED)

MODEL 065A09
SEAL
.06[1.5] THICK
(SUPPLIED)

B

B

A

A

UNLESS OTHERWISE SPECIFIED TOLERANCES ARE:

DIMENSIONS IN INCHES	DIMENSIONS IN MILLIMETERS [IN BRACKETS]
DECIMALS XX ± .01 XXX ± .005	DECIMALS X ± 0.3 XX ± 0.13
ANGLES ± 2 DEGREES	ANGLES ± 2 DEGREES
FILLETS AND RADII .003 - .005	FILLETS AND RADII [0.07 - 0.13]

DRAWN	ECB	1/3/08	MFG	PRR	1/3/08
CHK'D	DM	1/3/08	ENGR	RF	1/3/08
APP'D	NJL	1/3/08	SALES	DPC	1/3/08

TITLE
INSTALLATION DRAWING
MODEL 064B02 FLUSH MOUNTED
WATER COOLED ADAPTOR

PCB PIEZOTRONICS™
3425 WALDEN AVE. DEPEW, NY 14043
(716) 684-0001 E-MAIL: sales@pcb.com

CODE IDENT. NO. 52681	DWG. NO. 7586
SCALE: FULL	SHEET 2 OF 2