



**Model 080A128**

**Spotface tool, 1.25" diameter, with a drill bit for a 1/4-28 tap (tap not included)**

**Installation and Operating Manual**

**For assistance with the operation of this product,  
contact the PCB Piezotronics, Inc.**

**Toll-free: 800-959-4464**

**24-hour SensorLine: 716-684-0001**

**Fax: 716-684-3823**

**E-mail: [imi@pcb.com](mailto:imi@pcb.com)**

**Web: [www.imi-sensors.com](http://www.imi-sensors.com)**



## Repair and Maintenance

PCB guarantees Total Customer Satisfaction through its “Lifetime Warranty Plus” on all Platinum Stock Products sold by PCB and through its limited warranties on all other PCB Stock, Standard and Special products. Due to the sophisticated nature of our sensors and associated instrumentation, **field servicing and repair is not recommended and, if attempted, will void the factory warranty.**

Beyond routine calibration and battery replacements where applicable, our products require no user maintenance. Clean electrical connectors, housings, and mounting surfaces with solutions and techniques that will not harm the material of construction. Observe caution when using liquids near devices that are not hermetically sealed. Such devices should only be wiped with a dampened cloth—never saturated or submerged.

In the event that equipment becomes damaged or ceases to operate, our Application Engineers are here to support your troubleshooting efforts 24 hours a day, 7 days a week. Call or email with model and serial number as well as a brief description of the problem.

## Calibration

Routine calibration of sensors and associated instrumentation is necessary to maintain measurement accuracy. We recommend calibrating on an annual basis, after exposure to any extreme environmental influence, or prior to any critical test.

PCB Piezotronics is an ISO-9001 certified company whose calibration services are accredited by A2LA to ISO/IEC 17025, with full traceability to SI through N.I.S.T. In addition to our standard calibration services, we also offer specialized tests, including: sensitivity at elevated or cryogenic temperatures, phase response, extended high or low frequency response, extended range, leak testing, hydrostatic pressure testing, and others. For more information, contact your local PCB Piezotronics distributor, sales representative, or factory customer service representative.

## Returning Equipment

If factory repair is required, our representatives will provide you with a Return Material Authorization (RMA) number, which we use to reference any information you have already provided and expedite the repair process. This number should be clearly marked on the outside of all returned package(s) and on any packing list(s) accompanying the shipment.

## Contact Information

PCB Piezotronics, Inc.  
3425 Walden Ave.  
Depew, NY14043 USA  
Toll-free: (800) 828-8840  
24-hour SensorLine: (716) 684-0001  
General inquiries: [info@pcb.com](mailto:info@pcb.com)  
Repair inquiries: [rma@pcb.com](mailto:rma@pcb.com)

For a complete list of distributors, global offices and sales representatives, visit our website, [www.pcb.com](http://www.pcb.com).

## Safety Considerations

This product is intended for use by qualified personnel who recognize shock hazards and are familiar with the precautions required to avoid injury. While our equipment is designed with user safety in mind, the protection provided by the equipment may be impaired if equipment is used in a manner not specified by this manual.

Discontinue use and contact our 24-Hour Sensorline if:

- Assistance is needed to safely operate equipment
- Damage is visible or suspected
- Equipment fails or malfunctions

For complete equipment ratings, refer to the enclosed specification sheet for your product.

## Definition of Terms and Symbols

The following symbols may be used in this manual:



### **DANGER**

Indicates an immediate hazardous situation, which, if not avoided, may result in death or serious injury.

**CAUTION**

Refers to hazards that could damage the instrument.

**NOTE**

Indicates tips, recommendations and important information. The notes simplify processes and contain additional information on particular operating steps.

**The following symbols may be found on the equipment described in this manual:**



This symbol on the unit indicates that high voltage may be present. Use standard safety precautions to avoid personal contact with this voltage.



This symbol on the unit indicates that the user should refer to the operating instructions located in the manual.



This symbol indicates safety, earth ground.



PCB工业监视和测量设备 - 中国RoHS2公布表

PCB Industrial Monitoring and Measuring Equipment - China RoHS 2 Disclosure Table

部件名称	有害物质					
	铅 (Pb)	汞 (Hg)	镉 (Cd)	六价铬 (Cr(VI))	多溴联苯 (PBB)	多溴二苯醚 (PBDE)
住房	0	0	0	0	0	0
PCB板	X	0	0	0	0	0
电气连接器	0	0	0	0	0	0
压电晶体	X	0	0	0	0	0
环氧	0	0	0	0	0	0
铁氟龙	0	0	0	0	0	0
电子	0	0	0	0	0	0
厚膜基板	0	0	X	0	0	0
电线	0	0	0	0	0	0
电缆	X	0	0	0	0	0
塑料	0	0	0	0	0	0
焊接	X	0	0	0	0	0
铜合金/黄铜	X	0	0	0	0	0
本表格依据 SJ/T 11364 的规定编制。						
0：表示该有害物质在该部件所有均质材料中的含量均在 GB/T 26572 规定的限量要求以下。						
X：表示该有害物质至少在该部件的某一均质材料中的含量超出 GB/T 26572 规定的限量要求。						
铅是欧洲RoHS指令2011/65/ EU附件三和附件四目前由于允许的豁免。						

CHINA RoHS COMPLIANCE

Component Name	Hazardous Substances					
	Lead (Pb)	Mercury (Hg)	Cadmium (Cd)	Chromium VI Compounds (Cr(VI))	Polybrominated Biphenyls (PBB)	Polybrominated Diphenyl Ethers (PBDE)
Housing	O	O	O	O	O	O
PCB Board	X	O	O	O	O	O
Electrical Connectors	O	O	O	O	O	O
Piezoelectric Crystals	X	O	O	O	O	O
Epoxy	O	O	O	O	O	O
Teflon	O	O	O	O	O	O
Electronics	O	O	O	O	O	O
Thick Film Substrate	O	O	X	O	O	O
Wires	O	O	O	O	O	O
Cables	X	O	O	O	O	O
Plastic	O	O	O	O	O	O
Solder	X	O	O	O	O	O
Copper Alloy/Brass	X	O	O	O	O	O

This table is prepared in accordance with the provisions of SJ/T 11364.

O: Indicates that said hazardous substance contained in all of the homogeneous materials for this part is below the limit requirement of GB/T 26572.

X: Indicates that said hazardous substance contained in at least one of the homogeneous materials for this part is above the limit requirement of GB/T 26572.

Lead is present due to allowed exemption in Annex III or Annex IV of the European RoHS Directive 2011/65/EU.



*INDUSTRIAL MONITORING INSTRUMENTATION DIVISION*

## ***Spot Face Tool User Instructions***

---

### ***Operating Guide with Enclosed Warranty Information***

---

***3425 Walden Avenue, Depew, New York 14043-2495***

***Phone (716) 684-0003***

***Fax (716) 684-3823***

***Toll Free Line 1-800-959-4IMI***

***MANUAL NUMBER: 18671***  
***MANUAL REVISION: A***

---



A PCB DIVISION

INDUSTRIAL MONITORING INSTRUMENTATION DIVISION

**table of contents**

---

*Introduction*..... page 3

*Installation* ..... page 3

*Operation*..... pages 3-4

*Tool Maintenance* ..... page 4

*Spot Face Tool Illustration*..... page 5

**return procedure/customer service**

---

*Return Procedure* ..... page 6

*Customer Service* ..... page 6

***introduction***

---

Spot face tools are used to create a flat circular surface to mount an accelerometer. Each model has an installed center drill that is the correct tap drill for tapping a ¼-28 UNF-2B thread.

***installation***

---

Obtain a hand drill motor and install the shank end of the spot face tool into the chuck of the drill motor. Tighten the chuck and check the direction of rotation. The rotation should be counter clockwise when looking at the chuck end of the drill motor.

***operation***

---

Choose the area on the surface where the accelerometer is to be installed. Using a center punch, mark the spot of the center of the accelerometer. Apply a small amount of light oil to the surface to be used as a cutting fluid.

Apply the point of the center drill on the spot face tool to the center punch mark, grip the drill motor firmly and begin drilling.

The drill motor should be kept as perpendicular to the axis that is going to be measured as possible. Often on castings and molded parts the axis is not necessarily perpendicular to the surface being prepared. A cross-check or torpedo level is very helpful in determining perpendicularity.

The revolution speed of the drill motor should be kept between 150 and 350 RPM to optimize the life of the tool. Allow the tool to do the cutting. Do not apply excessive pressure while drilling, this will accelerate tool wear. The addition of a lubricant or cutting fluid during the cutting process will also greatly increase tool life.



***operation continued . . .***

---

The depth of the cut is determined by the perpendicularity of the surface to the axis being measured. Remove enough material so that the entire bottom surface of the accelerometer is in contact with the spot face. The maximum depth of cut should not exceed .040”.

The position of the center drill in the spot face tool can also be adjusted for different drill depths to accommodate for the wall thickness and the material of the unit to be monitored.

***tool maintenance***

---

After extended use the spot face tools may wear and become dull. The tool can be sharpened using standard sharpening techniques. Refer to your local machine shop for sharpening.

1/4 - 28	1.00 [25.4]	.218 [5.54]	080A127
1/4 - 28	1.25 [31.8]	.218 [5.54]	080A128
1/4 - 28	1.50 [38.1]	.218 [5.54]	080A129
1/4 - 28	2.25 [57.2]	.218 [5.54]	080A134
10 - 32	1.00 [25.4]	.159 [4.04]	080A137
1/4 - 28	.75 [19.1]	.218 [5.54]	080A138
"A"	"B"	"C"	MODEL NUMBER

3.) DIMENSIONS ARE IN INCHES, DIMENSIONS IN BRACKETS ARE IN MILLIMETERS

 TAP DEPTH FOR HARD STEEL:  $\nabla .145 [3.68]$   
TAP DEPTH FOR CASTINGS:  $\nabla .255 [6.48]$

 DIMENSION FOR HARD STEEL:  $.215 [5.46]$   
DIMENSION FOR CASTINGS:  $.325 [8.26]$

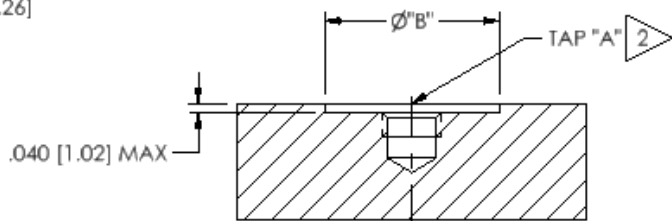
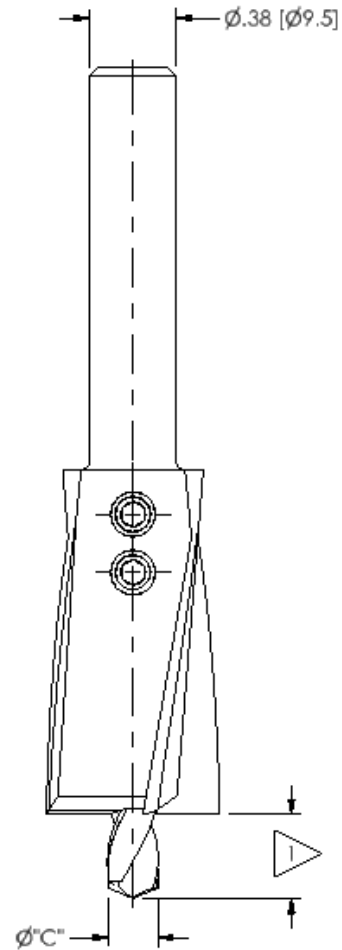



A PCB DIVISION

INDUSTRIAL MONITORING INSTRUMENTATION DIVISION

### ***return procedure***

---

To expedite returned instrumentation, contact a factory IMI applications engineer for a **RETURN MATERIAL AUTHORIZATION (RMA) NUMBER**. Please have information available such as model and serial number. Also, to insure efficient service, *provide a written description of the symptoms and problems with the equipment to a local sales representative or distributor, or contact IMI if none are located in your area.*

Customers outside the U.S. should consult their local IMI distributor for information on returning equipment. For exceptions, please contact the International Sales department at IMI to request shipping instructions and an RMA. For assistance, please call (716) 684-0003, or fax us at (716) 684-3823. You may also receive assistance via e-mail at [imi@pcb.com](mailto:imi@pcb.com) or visit our web site at [www.pcb.com](http://www.pcb.com).

### ***customer service***

---

IMI, a division of PCB Piezotronics, guarantees **Total Customer Satisfaction**. If, at any time, for any reason, you are not completely satisfied with any IMI product, IMI will repair, replace, or exchange it at no charge. You may also choose, within the warranty period, to have your purchase price refunded.

IMI offers to all customers, at no charge, 24-hour phone support. This service makes product or application support available to our customers, day or night, seven days a week. When unforeseen problems or emergency situations arise, call the **IMI Hot Line at (716) 684-0003**, and an application specialist will assist you.



# **IMI SENSORS**

**A PCB DIVISION**

3425 Walden Avenue, Depew, NY 14043-2495

Phone: (716) 684-0003 • USA Fax: (716) 684-3823 • INTL Fax: (716) 684-4703

*ICP ® is a registered trademark of PCB Piezotronics, Incorporated,  
which uniquely identifies PCB sensors that incorporate built-in microelectronics.*