



**Model 086M91**

**Modally Tuned® Impulse Hammer w/force sensor & hard plastic tip, 0 to 5k lbf, 1 mV/lbf (0.23 mV/N), 10 ft. attached coiled cable with BNC plug**

**Installation and Operating Manual**

**For assistance with the operation of this product,  
contact the PCB Piezotronics, Inc.**

**Toll-free: 716-684-0001  
24-hour SensorLine: 716-684-0001  
Fax: 716-684-0987  
E-mail: [info@pcb.com](mailto:info@pcb.com)  
Web: [www.pcb.com](http://www.pcb.com)**



## Installation and Operating Manual ICP® Modal / Impact / Impulse Hammer

### CONTENTS:

Introduction.....	1.0
Description.....	2.0
Installation and Operation.....	3.0
Testing .....	4.0
Calibration .....	5.0
Maintenance.....	6.0
Precautions .....	7.0
Warranty and Service .....	8.0



### 1.0 INTRODUCTION

The ICP® Modal / Impact / Impulse Hammer adapts your FFT analyzer for structural behavior testing. Impulse testing of the dynamic behavior of mechanical structures involves striking the test object with the force-instrumented hammer and measuring either the resultant motion with an accelerometer or the acoustic signature with a microphone. Structures generally respond as (1) rigid or elastic bodies, (2) finite elements, lumped constant models and (3) distributed parameter models conducting stress-strain (sound) waves.

Testing the functional transfer and transactional characteristics of a mechanical structure involves mounting the accelerometer at one location of interest and striking the test object with the hammer. Modal analysis and modeling involves fixing the accelerometer(s) at one location, impacting the structure at one point and then moving the accelerometer(s) to other points of interest. Integration of the acceleration signal yields velocity compliance, impedance and mobility. The hammer impulse consists of a nearly-constant force over a broad frequency range, and is therefore capable of exciting all resonances in that range. The hammer, size, length, material and velocity at impact determine the amplitude and frequency content (wave shape) of the force impulse. The impact cap material generally determines energy content. The force spectrums of an impact on a stiff steel mass for hammers with their available tips are shown below.

PCB® impulse hammers are available in sizes ranging from the mini-impulse hammer to the 12 lb sledgehammer. All sensors in this system are classified as ICP® (Integrated Circuit Piezoelectric), low impedance, voltage-mode sensors. Microelectronic, built-in amplifiers standardize sensitivities within a few percent of nominal value, which is adequate for most dynamic applications.

086E80 Family Frequency Response Curves

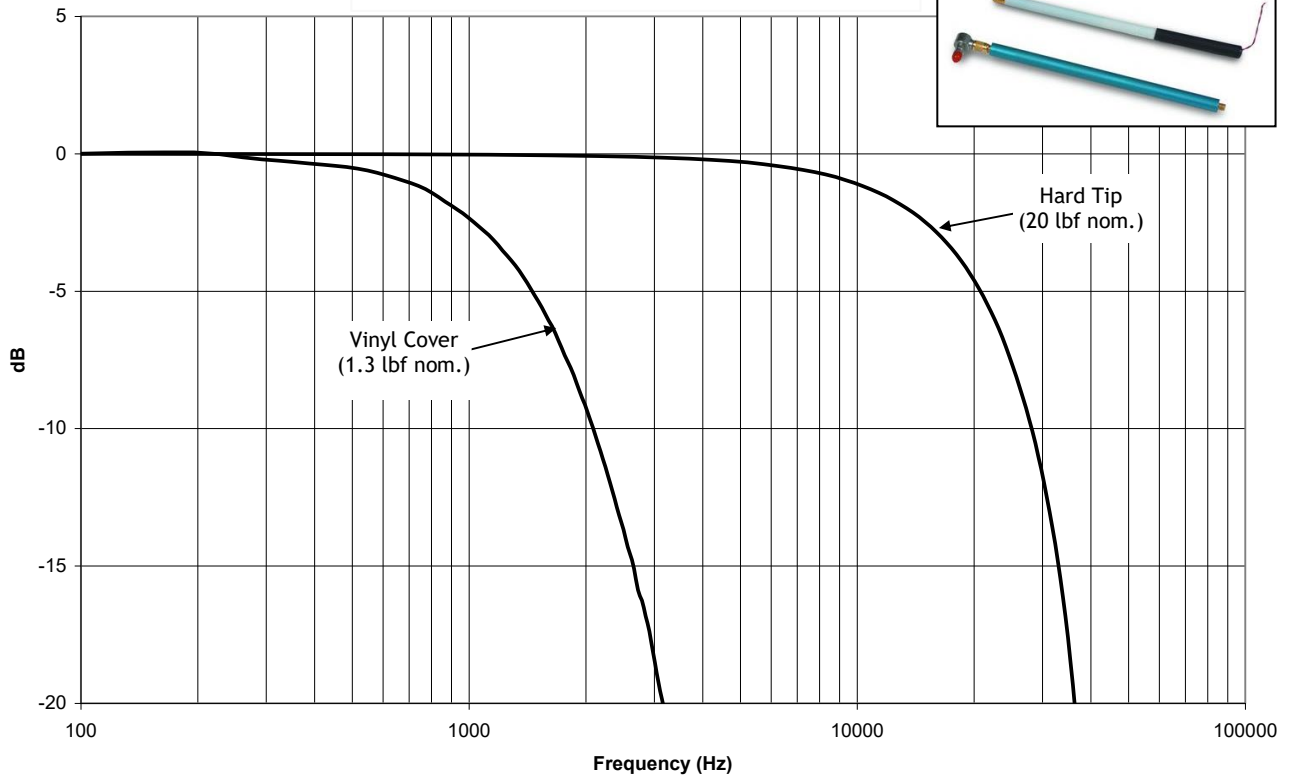

086C01 Family Frequency Response Curves

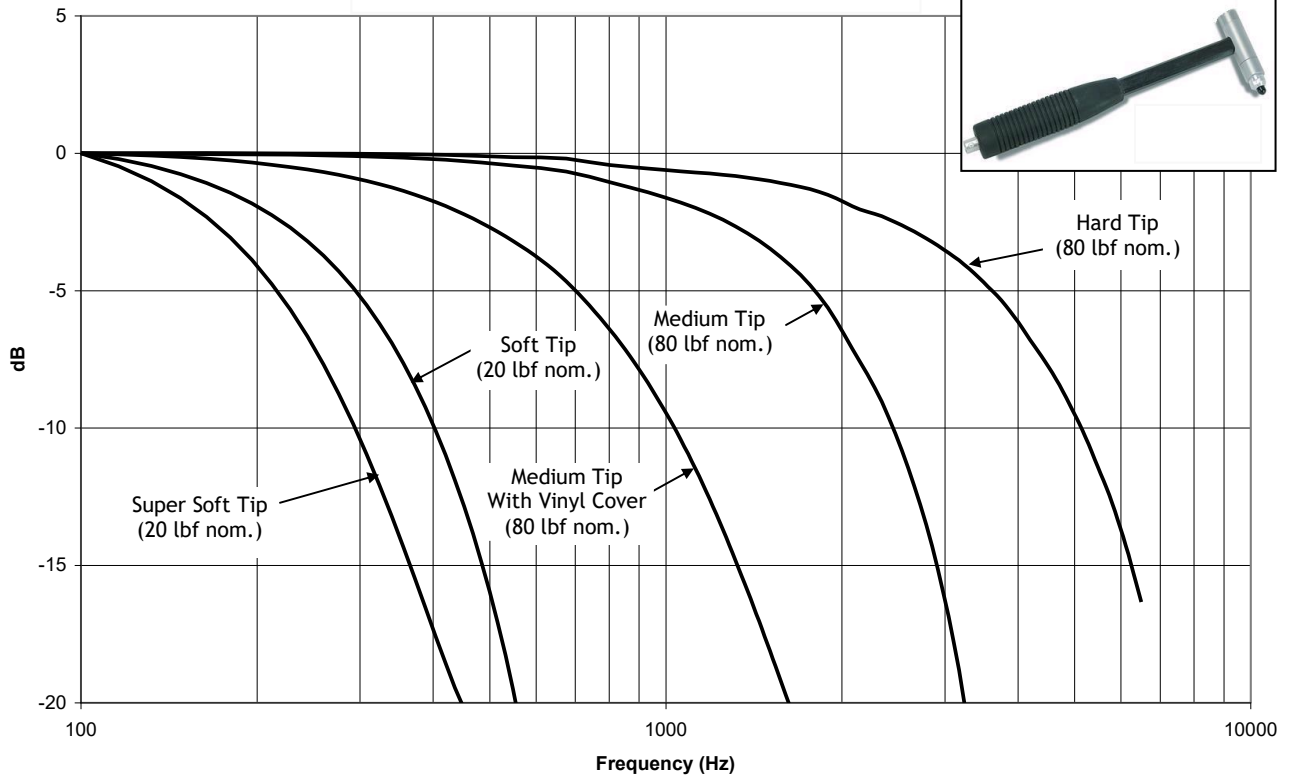

### 086C02, C03 & C04 Family Frequency Response Curves

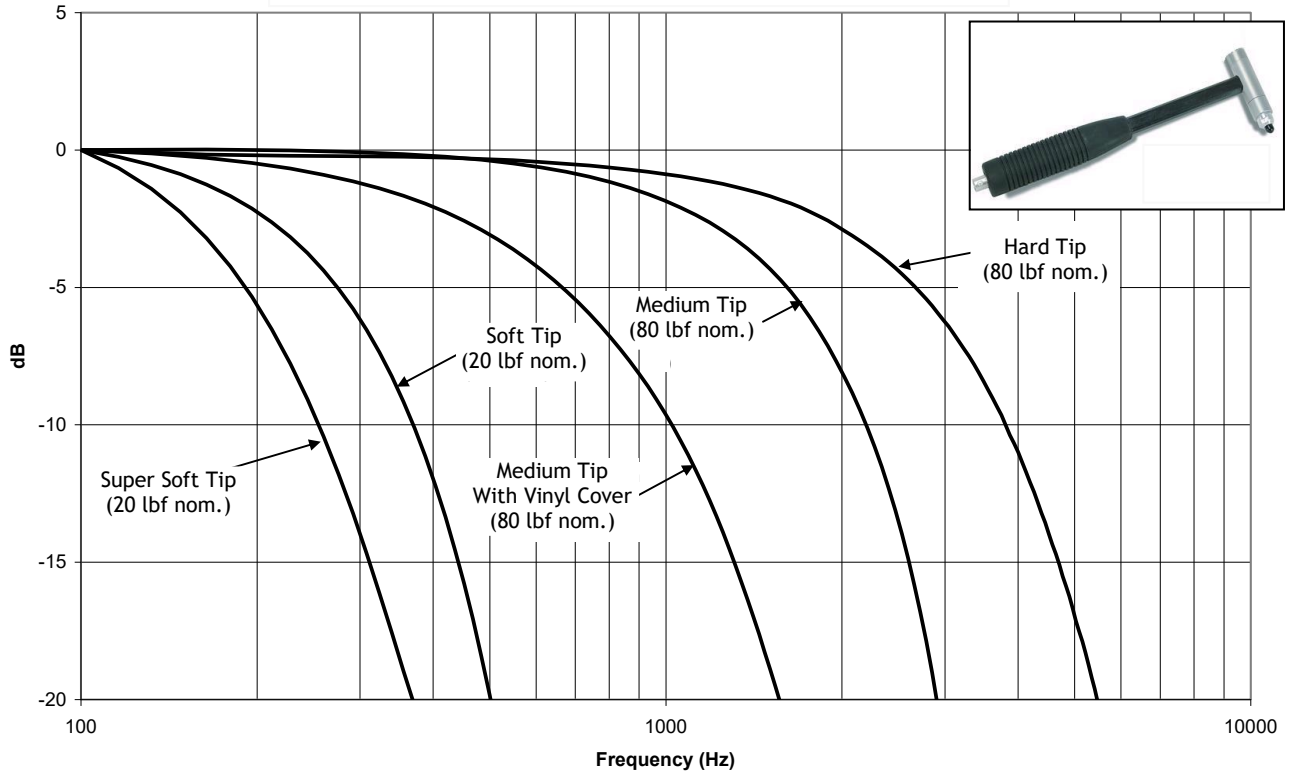

### 086D05 Family Frequency Response Curves

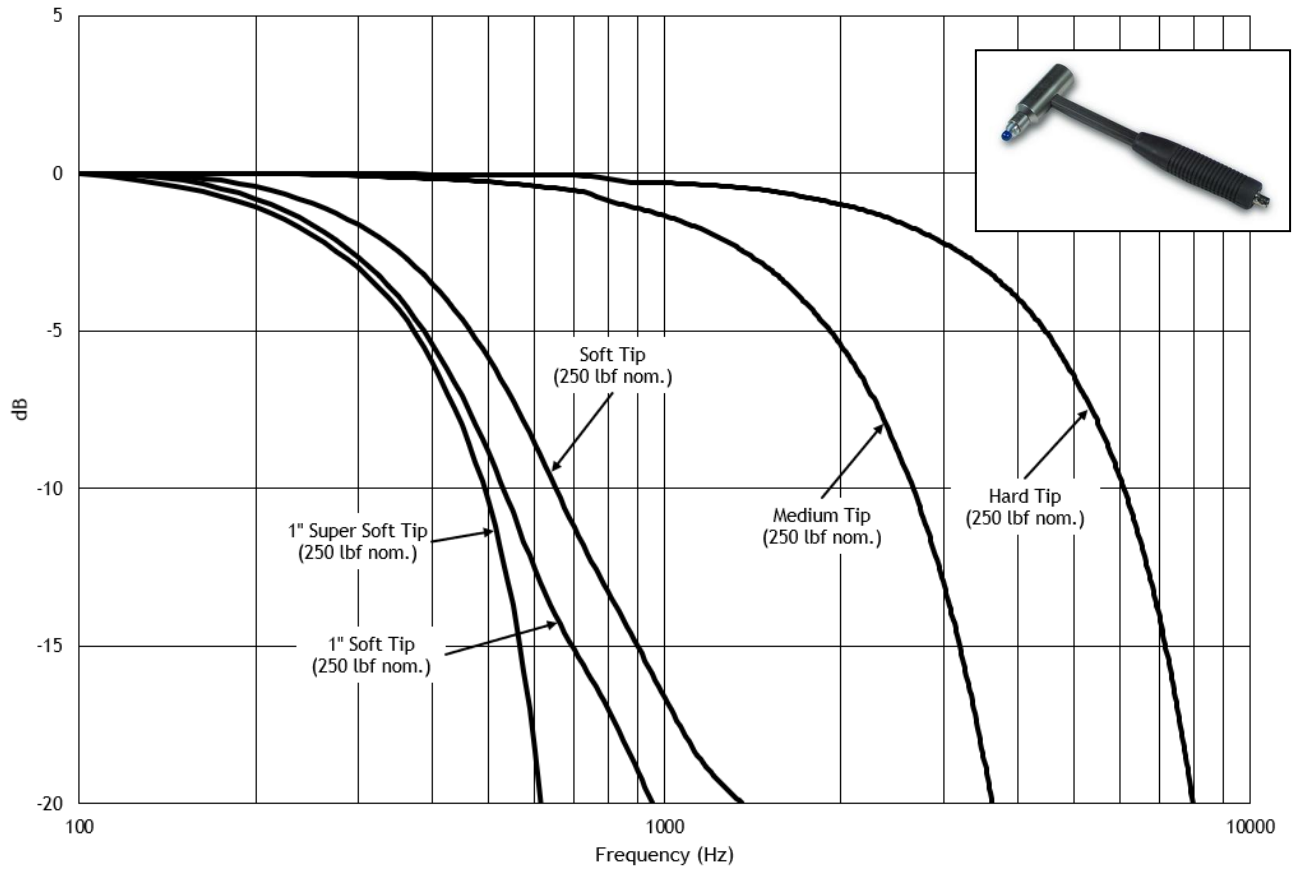

### 086D20 Family Frequency Response Curves

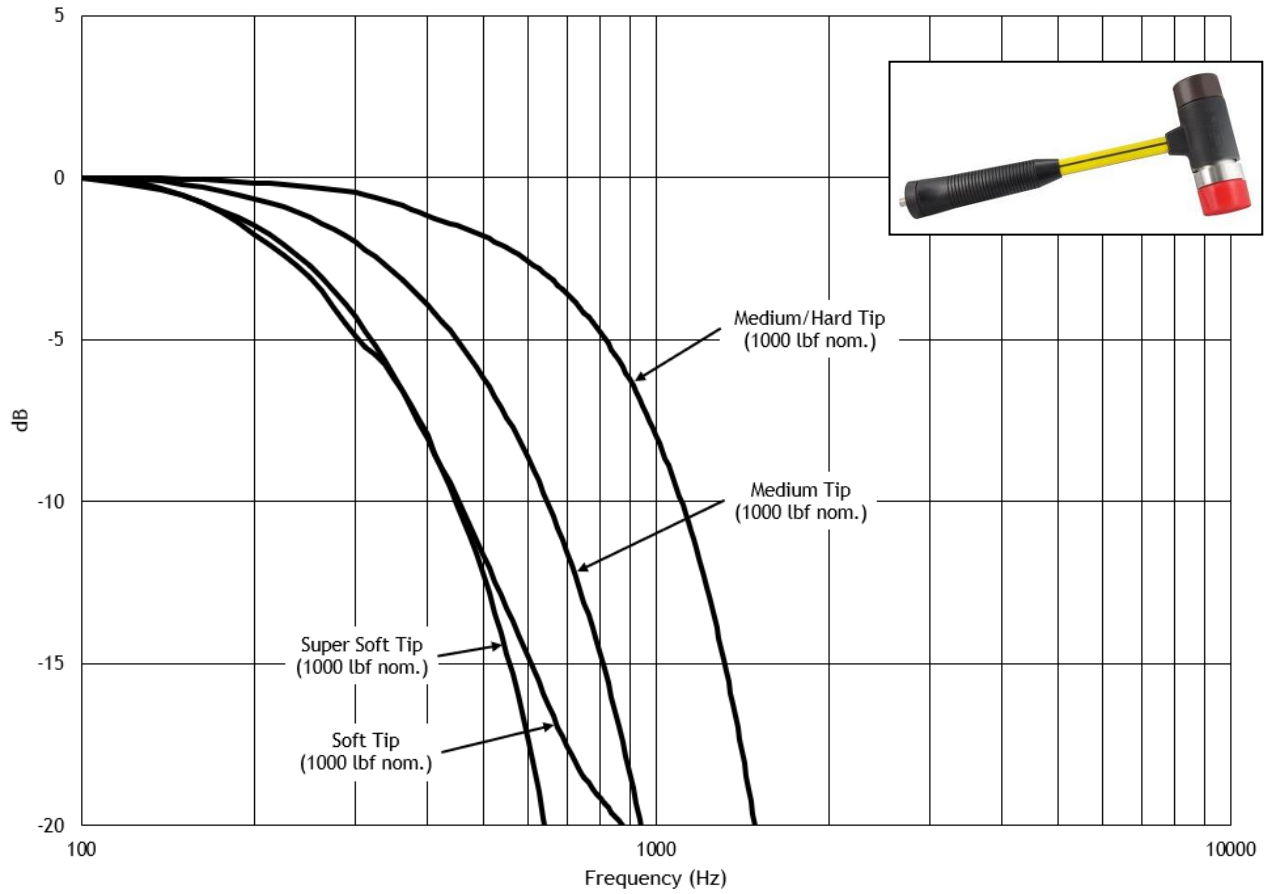

### 086D50 Family Frequency Response Curves

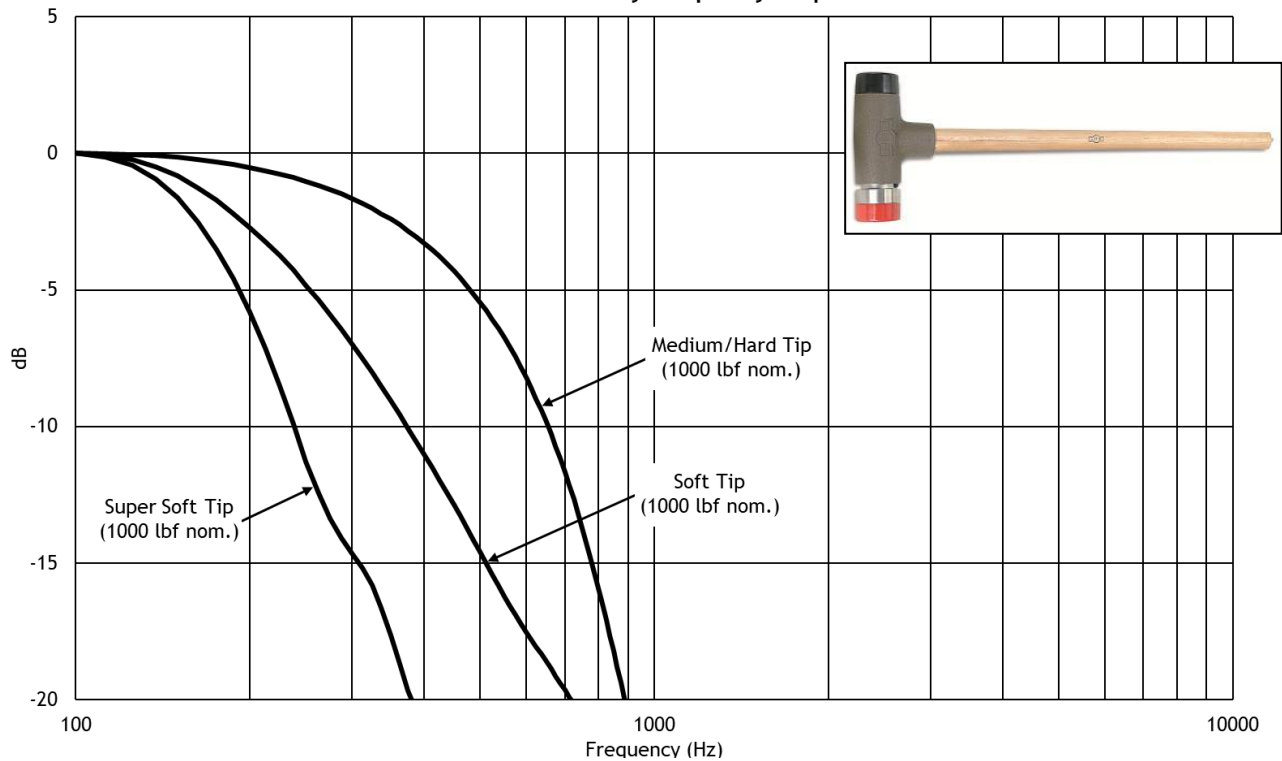

Hammer model selection involves determining the size and mass of the hammer structure which will provide the force amplitude and frequency content required for proper excitation of the structure under test. Large, heavy structures like locomotive frames, tanks and bridges require an instrumented sledhammer; small structures like compressor blades often require mini-hammers. Some very large structures may require a massive mechanical ram instrumented with a force-sensing impact head.

## **2.0 DESCRIPTION**

These hammer consists of an integral, ICP<sup>®</sup> quartz force sensor mounted on the striking end of the hammer head. The sensing element functions to transfer impact force into electrical signal for display and analysis. It is structured with rigid quartz crystals and a built-in, micro-electronic, unity gain amplifier. The cable is connected to the end of the handle for convenience, and to avoid connector damage in the event of a “miss hit.”

The ICP<sup>®</sup> sensor operates over a standard two-wire cable from a PCB<sup>®</sup> power unit. For reasons of safety, the easily-repairable ribbon wire cable is intended to be the weak link in larger hammer design. The ICP<sup>®</sup> signal conditioner supplies constant current excitation to the sensor over the signal lead and AC couples the output signal. Many FFT analyzers and data acquisition systems have ICP<sup>®</sup> power supply built in.

The hammer is a single, integral unit. Laser-welded construction of the sensor element insures reliable operation in adverse environments. The mechanical assembly is locked together with a structural epoxy adhesive, so it should not be taken apart except at the factory.

The striking end of the hammer has a threaded hole for installation of a variety of impact tips. The tip functions to transfer the force of impact to the sensor and protects the sensor face from damage. Tips of different stiffness allow you to vary the pulse width and frequency content of the force. The specific frequency range can be found in the datasheet supplied with hammer. An extender mass, supplied with most hammers, allows further tuning by concentrating more energy at lower frequencies.

## **3.0 INSTALLATION AND OPERATION**

The hammer is assembled and locked together with structural adhesive at the factory. The tips and extender mass install at opposite ends of the hammer via 10-32 threaded studs. In the case of the model 086E80 mini impulse hammer, the handle is removable.

1. With the applicable cables, connect the hammer to an ICP<sup>®</sup> signal conditioner, and then connect that to your analyzer, as shown in the applicable signal conditioners' manual.
2. Tighten the cable connectors securely by hand to insure a good electrical contact.
3. Switch the power on, and wait a minute or two for the sensor amplifier to turn on and for the coupling capacitor to fully charge. Check the power unit's meter for normal operation (e.g. meter pointer pointing in green area).
4. If a meter's pointer points in the red area, look for shorted cables or connections. If a meter's pointer points in the yellow area, look for open cables or connections.
5. Connect the accelerometer(s) in a similar manner; referring to the appropriate operating guides for the accelerometer(s) and power unit. When all power unit meters indicate normal operation (green), proceed with the tests following all sensor, power unit and analyzer operating instructions.

## 4.0 TESTING

Generally speaking, the impact tips affect the hammer impulse frequency content, and the extender affects the signal energy level. Frequency content and energy level are interrelated, so both will be affected by different hammer structures. Hammer velocity at impact will also affect both. In general, massive structures with lower stiffness require the use of the extender and soft impact tip to adequately excite low frequency resonances.

The frequency range of the hammer can be varied by changing the type of tip used. The following guidelines can be used to determine the ideal hammer configuration for a particular test setup:

1. For a higher frequency response, use a stiffer tip without the extender mass.
2. For a lower frequency response, use a softer tip and install the extender mass.
3. To increase motion signal energy, increase the impact velocity and/or hammer mass.

When using the model 086E80 mini impact hammer, the model 084A17 handle is designed for use in frequency ranges lower than those reached when using the model 084A14 handle. When using the model 084A17 handle, best results are achieved by mounting the model 084A13 extender mass to the back of the hammer as shown on the outline drawing. This will improve the low frequency content of the force input to the structure, as well as improve the “feel” of the hammer by offsetting any effective mass added to the handle base by an attached cable.

To test the behavior of your structure and to tailor the frequency bandwidth of the force, follow the following procedure:

1. Strike the test object with the hammer and process the results. Always take several averages to reduce the effects of spurious noise.

**CAUTION:** *Never impact without a hammer tip properly installed on the sensor element. In the case of the model 086E80 mini impact hammer, the sensor element is pre-installed with a steel tip.*

2. Check the measured results for signal quality (adequate signal-to-noise), no overloads (overload lights or sharp flattening of time history peaks) and no double impacts.
3. Analyze results for frequency content, and check to ensure that the reasonably flat portion of the force spectrum is sufficient to cover the structural resonances present in the acceleration spectrum. Often signal energy is sufficient to excite structural resonances at 20 dB below initial low frequency force levels.

During testing, occasionally check and tighten the electrical and mechanical connections. Repeated impacting tends to loosen them, which may result in erratic and noisy signals.

Although modal tuning has done much to eliminate this possibility, bouncing (multiple impacts) or penetration may still occur when using too heavy a hammer on too light a structure or section of a structure. This will appear as an oscillatory component superimposed on the spectrum in your data. Reject such data. Some skill and practice may still be required when testing lighter structures.

PCB's ICP<sup>®</sup> power units providing greater than 10 volts positive signal range (three x 9 volt batteries) prevent undetected overloads in the power unit. Distortion, undershoot and oscillation of the impulse time history, as viewed on the analyzer display, is caused by ringing of the analyzer's anti-aliasing filters, which is their normal behavior. To view the correct impulse waveform, switch the analyzer to a high-frequency range.

When configuring your oscilloscope or data acquisition system, it is recommended that the input be set to DC coupled. This is because, in some cases, the time constant associated with the equipment's AC coupling circuit is less than that of the impulse hammer and PCB ICP<sup>®</sup> power units. This will cause a small offset in the output voltage of the hammer after impact, which will appear as a negative dip in the response on the down slope of the response with a gradual rise back to zero over a period of time.

## **5.0 CALIBRATION**

Calibration involves testing the functional transfer behavior (sensitivity) of the sensor structure in controlled transactions and environments.

Different hammer structures have different sensitivities. This is because the test structure experiences a force greater than the crystal-sensing elements. The force of impact on the test structure is a function of the total mass of the hammer, while the force on the crystals is a function of only the mass behind them (the impact tip is in front of the crystal-sensing element). Their differences, which depend on the ratio of the tip mass to the head mass, is automatically compensated for when the hammer is properly calibrated, since the extender mass is behind the sensing element. When used, it results in a slight increase in voltage sensitivity (as shown on calibration certificate). Each hammer structure can be easily calibrated to ensure the most accurate data.

A hammer can be calibrated by hitting a freely-suspended mass instrumented with a reference accelerometer. According to Newton's second law of motion, at any instant in time, the force experienced by the mass is simply the mass multiplied by the measured acceleration. On a storage oscilloscope, dividing the peak output signal of the hammer (mV) by the mass (lb or kg), times the peak acceleration (g), gives the hammer sensitivity directly in mV/lb or mV/kg.

Calibration on a FFT analyzer produces the same result as a function of frequency. Since the transfer function of a mass behaving as a rigid body is a consistent (1/M) ratio, the force and the acceleration signals produces a calibration constant (ideally 1/M) for each discrete frequency. The effects of a non-modally tuned hammer will be readily apparent when performing this calibration.

The mass, pendulously suspended or placed on a piece of foam rubber, will behave as a rigid body. Hitting such an instrumented mass is also a good way of checking the normal operation of the hammer and instruments prior to testing. This procedure builds confidence in data results.

## **6.0 MAINTENANCE**

The sealed construction of the sensing element and the bonded construction of the hammer preclude field maintenance. Should service be required, first replace the cables (cables are often the source of trouble) and test operation again. If necessary, return the unit to the factory with a note describing the problem.

## 7.0 PRECAUTIONS

Although hammers are very rugged in construction, damage can result from misuse. When observed, the following precautions can ensure long life and accurate data.

1. Do not attempt to dismantle sensor element from hammer structure. All service should be performed at the factory.
2. Never generate more than 5 times the rated impact force range with any hammer. Generally, observe the force rating for five volts output. Excessive impact force may destroy the built-in miniature electronics.
3. Never strike an object without an impact tip properly installed in front of the force-sensing element. Damaging the precision-lapped surface of the hammer sensor can affect its behavior.
4. During testing, periodically check and tighten tip, extender and cable connections to ensure continued proper operation. Machined flats in the tips and extender facilitate tightening and removal.
5. Do not apply voltage to unit without constant current protection.
6. Do not apply more than 20 mA of current.
7. Do not exceed 30 volts supply voltage.
8. Do not subject units to temperatures above 250°F (121°C).
9. Ground the analyzer to prevent Electromagnetic Interference (EMI) from fluorescent lights or other sources effecting the signal.

## 8.0 WARRANTY AND SERVICE

All equipment and repair services provided by PCB Piezotronics, Inc. are covered by a warranty against defective material and workmanship under a **Total Customer Satisfaction** policy. See the supplemental sheet, contained with this manual, for information on our service, repair and return policies, procedures and instructions. When unexpected problems arise, call our 24-Hour SensorLine<sup>SM</sup> to discuss your immediate dynamic instrumentation needs with a factory representative. PCB guarantees **Total Customer Satisfaction**. If, at any time, for any reason, you are not completely satisfied with any PCB product, PCB will repair, replace, or exchange it at no charge. You may also choose to have your purchase price refunded. Contact PCB for a complete statement of our warranty.

3425 Walden Avenue, Depew, NY 14043-2495  
E-Mail: [info@pcb.com](mailto:info@pcb.com)  
Website: [www.pcb.com](http://www.pcb.com)

24-hour SensorLine<sup>SM</sup>: 716-684-0001  
Fax: 716-684-0987  
Toll-free (in the US): 800-828-8840

A PCB GROUP COMPANY

ISO 9001 CERTIFIED

A2LA ACCREDITED to ISO 17025

© 2025 PCB Group, Inc. In the interest of constant product improvement, specifications are subject to change without notice. PCB and ICP are registered trademarks of PCB Group, Inc. SensorLine is a service mark of PCB Group, Inc. All other trademarks are properties of the respective owners.

Manual Number: 19198  
Manual Revision: **D**  
ECO **56173**



VIB-086 Manual – 10/25  
Printed in the U.S.A.

Performance	ENGLISH	SI	
Sensitivity(± 15 %)	1 mV/lbf	0.23 mV/N	
Measurement Range	± 5,000 lbf pk	± 22,000 N pk	
Frequency Range(- 10 dB)(Hard Tip)	1,000 Hz	1,000 Hz	[1][2]
Resonant Frequency	≥ 12 kHz	≥ 12 kHz	
Non-Linearity	≤ 1 %	≤ 1 %	
Electrical			
Excitation Voltage	20 to 30 VDC	20 to 30 VDC	
Constant Current Excitation	2 to 20 mA	2 to 20 mA	
Output Impedance	< 100 Ohm	< 100 Ohm	[1]
Output Bias Voltage	8 to 14 VDC	8 to 14 VDC	
Discharge Time Constant	≥ 1,400 sec	≥ 1,400 sec	[1]
Physical			
Sensing Element	Quartz	Quartz	
Sealing	Hermetic	Hermetic	
Hammer Mass	2.4 lb	1.1 kg	
Head Diameter	2.0 in	5.1 cm	
Tip Diameter	2.0 in	5.1 cm	
Hammer Length	14.5 in	37 cm	
Electrical Connection Position	Bottom of Handle	Bottom of Handle	
Electrical Connector	BNC Jack	BNC Jack	
Cable Type	050 2-cond	050 2-cond	
Cable Length	10 ft	3.05 m	

**OPTIONAL VERSIONS**

Optional versions have identical specifications and accessories as listed for the standard model except where noted below. More than one option may be used.

**NOTES:**  
 [1]Typical.  
 [2]Varies depending on test structure. These values are from hitting a stiff steel mass. Hammer did not have extender mass attached.

**SUPPLIED ACCESSORIES:**  
 Model 084B63 Tip, 2", Med./Hard, Red/Black (3)  
 Model HCS-2 Calibration of Series 086 instrumented impact hammers (1)

Entered: ND	Engineer: GD	Sales: BS	Approved: BAM	Spec Number:
Date: 03/12/2025	Date: 03/12/2025	Date: 03/12/2025	Date: 03/12/2025	18540

All specifications are at room temperature unless otherwise specified.  
 In the interest of constant product improvement, we reserve the right to change specifications without notice.  
 ICP® is a registered trademark of PCB Piezotronics, Inc.

**PCB PIEZOTRONICS**  
AN AMPHENOL COMPANY

Phone: 716-684-0001  
 Fax: 716-684-0987  
 E-Mail: info@pcb.com

3425 Walden Avenue, Depew, NY 14043

18182

PCB Piezotronics Inc. claims proprietary rights in the information disclosed hereon. Neither it nor any reproduction thereof will be disclosed to others without written consent of PCB Piezotronics Inc.

APPLICATION		
NEXT ASS'Y	USED ON	VAR

REVISIONS				
REV	DESCRIPTION	ECN	DATE	APP'D

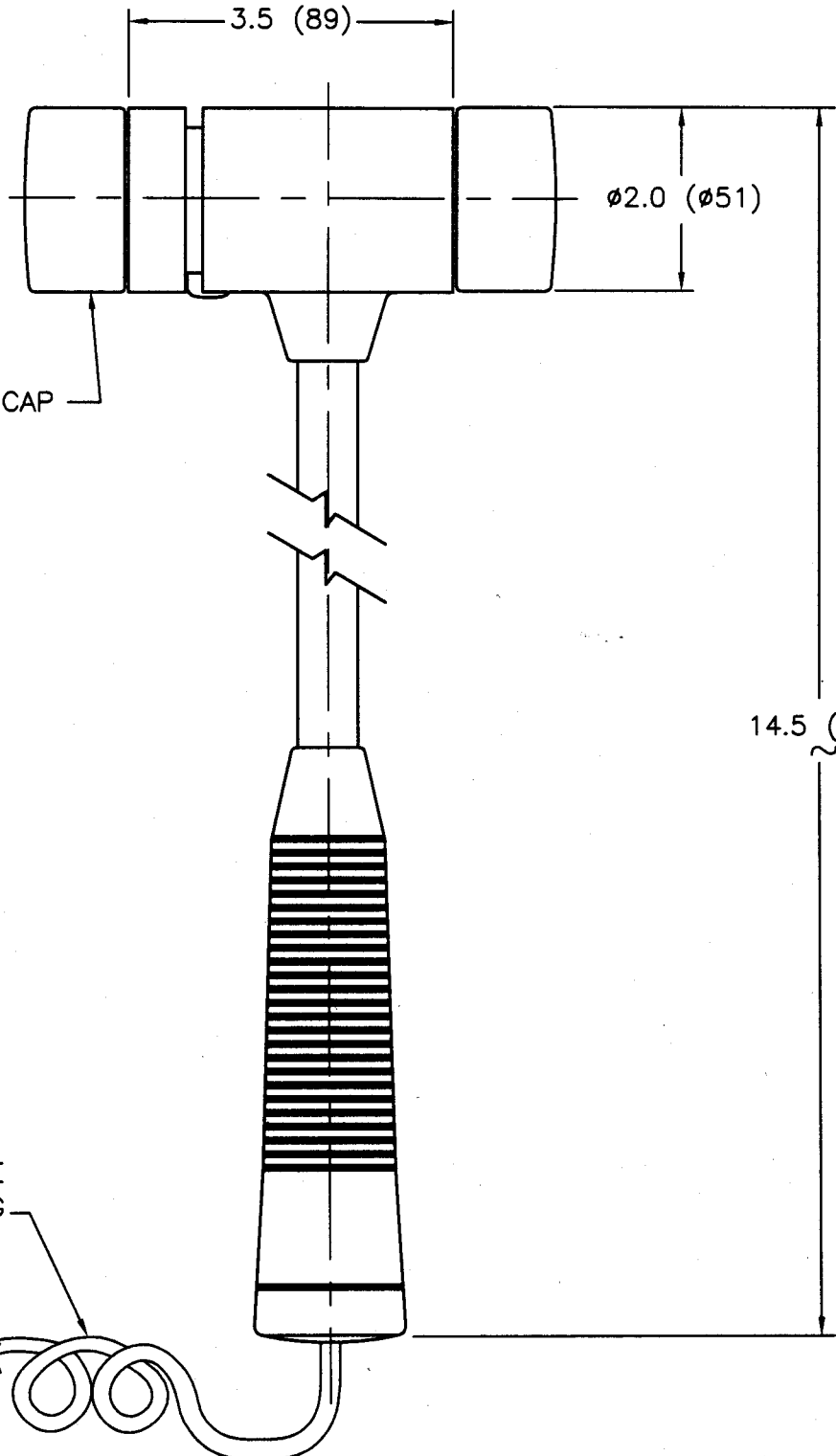

REMOVEABLE IMPACT CAP  
TYPICAL EACH END

050 INTEGRAL CABLE  
10ft.(3 METERS) LONG

BNC JACK

14.5 (368)

UNLESS SPECIFIED TOLERANCES		DRAWN	CHK'D	APP'D	MFG	ENGR	SALES	PCB PIEZOTRONICS™	
DIMENSIONS IN INCHES	DIMENSIONS IN MILLIMETERS (IN PARENTHESIS)	<i>SWZ</i>	<i>SWZ</i>	<i>Phit</i>	<i>AL</i>	<i>ARC</i>	<i>WDL</i>	3425 WALDEN AVE. DEPEW, NY 14043	18182
DECIMALS XX ±.01 XXX ±.005	DECIMALS XX ±0.3 XXX ±0.13	<i>1/2/02</i>	<i>2/2/02</i>	<i>1/23/02</i>	<i>1/23/02</i>	<i>1/23/02</i>	<i>1/16/02</i>	(716) 684-0001 EMAIL: SALES@PCB.COM	
ANGLES ±2 DEGREES	ANGLES ±2 DEGREES	TITLE		OUTLINE DRAWING		CODE IDENT. NO.		52681	
FILLETS AND RADII .003 - .005	FILLETS AND RADII (0.07 - 0.13)	MODEL 086M91		IMPULSE HAMMER		SCALE: .5X			
DD011 REV. B 03/13/98		SHEET 1 OF 1							



**Model 084B63**

**Medium/hard, red or black, 2" face, 3/8-16 threaded tip (for Model 086D20)**

**Installation and Operating Manual**

**For assistance with the operation of this product,  
contact the PCB Piezotronics, Inc.**

**Toll-free: 716-684-0001**

**24-hour SensorLine: 716-684-0001**

**Fax: 716-684-0987**

**E-mail: [info@pcb.com](mailto:info@pcb.com)**

**Web: [www.pcb.com](http://www.pcb.com)**



PCB Piezotronics Inc. claims proprietary rights in the information disclosed hereon. Neither it nor any reproduction thereof will be disclosed to others without the written consent of PCB Piezotronics Inc.

REVISIONS

REV	DESCRIPTION	DIN
NR	RELEASED TO DRAFTING	55566

80143

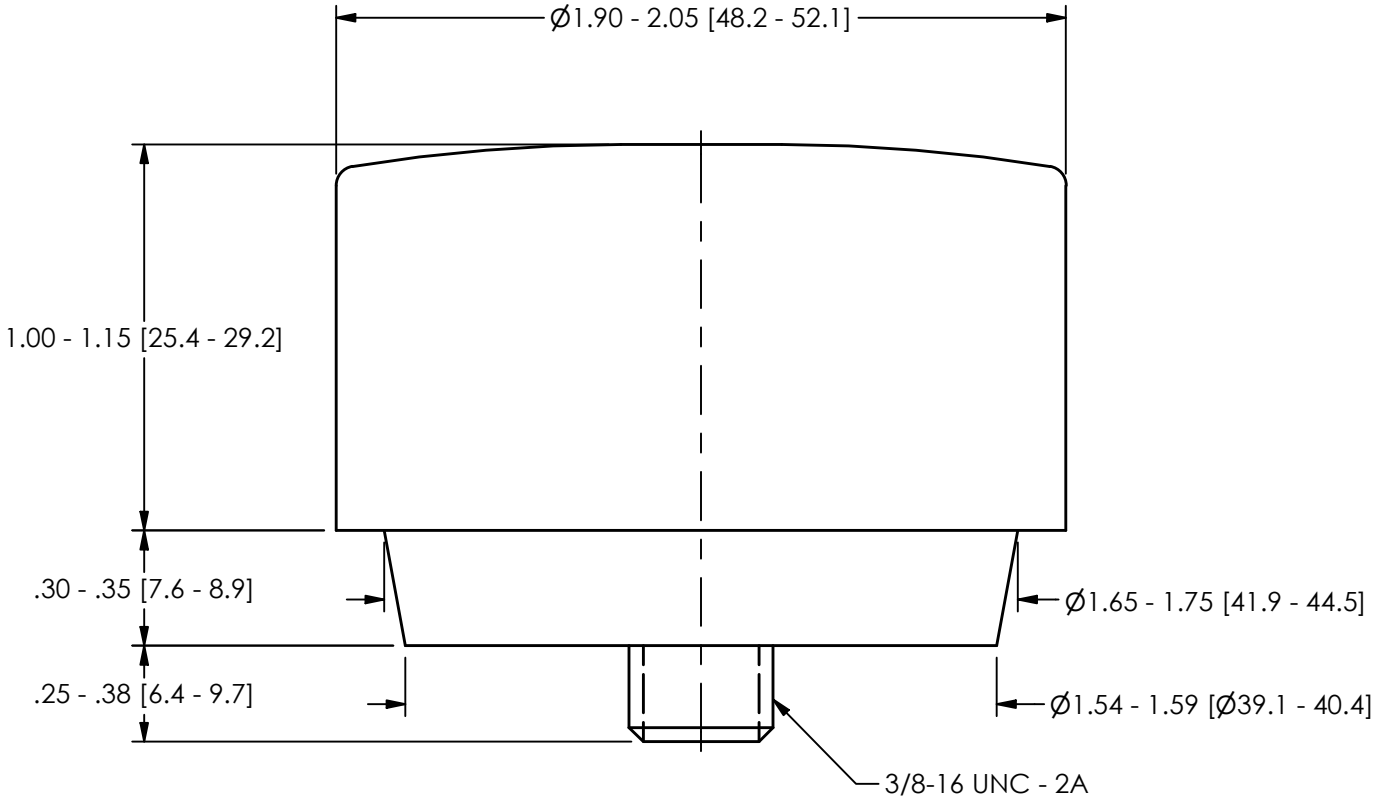

084B63	RED OR BLACK	MEDIUM/HARD
084B62	GREEN OR RED	MEDIUM
084B61	ORANGE OR BROWN	SOFT
084B60	PINK OR GRAY	SUPER SOFT
MODEL	COLOR	HARDNESS CATEGORY

UNLESS OTHERWISE SPECIFIED TOLERANCES ARE:

DIMENSIONS IN INCHES		DIMENSIONS IN MILLIMETERS [IN BRACKETS]	
DECIMALS XX ±.03		DECIMALS X ± 0.8	
XXX ±.010		XX ± 0.25	
ANGLES ± 2 DEGREES		ANGLES ± 2 DEGREES	
CABLE TOLERANCES IN ENGLISH		CABLE TOLERANCES IN METRIC	
1" ≤ LENGTH < 1'	= +1"/ - 0	2.54cm ≤ LENGTH < 30.5cm	= +2.54cm/ - 0
1' ≤ LENGTH < 5'	= +2"/ - 0	30.5cm ≤ LENGTH < 1.5m	= +5.1cm/ - 0
5' ≤ LENGTH < 100'	= +6"/ - 0	1.5m ≤ LENGTH < 30.5m	= +15.2cm/ - 0
100' ≤ LENGTH	= +1"/ - 0	30.5m ≤ LENGTH	= +30.5cm/ - 0
FILLETS AND RADII	.003 - .005	FILLETS AND RADII	0.07 - 0.13

DRAWN		CHECKED		ENGINEER	
AME	3/6/25	JDM	3/6/25	GCD	3/6/25
TITLE					
OUTLINE DRAWING 2" HAMMER TIP					

**PCB PIEZOTRONICS**  
AN AMPHENOL COMPANY

3425 WALDEN AVE. DEPEW, NY 14043  
(716) 684-0001 E-MAIL: sales@pcb.com

CODE IDENT. NO. 52681	SIZE A	DWG. NO. 80143
SCALE: 2X	SHEET 1 OF 1	