



Model 102B13

Cryogenic ICP® pressure sensor, 10k psi, 0.5 mV/psi, 3/8-24 mtg thd, ground isolated with safety wire holes

Installation and Operating Manual

This manual contains the 061A01, 14907-03 installation and operating manuals that comprise a Model 102B13 Cryogenic ICP® pressure sensor, 10k psi, 0.5 mV/psi, 3/8-24 mtg thd, ground isolated with safety wire holes kit.

**For assistance with the operation of this product,
contact the PCB Piezotronics, Inc.**

**Toll-free: 716-684-0001
24-hour SensorLine: 716-684-0001
Fax: 716-684-0987
E-mail: info@pcb.com
Web: www.pcb.com**



Repair and Maintenance

PCB guarantees Total Customer Satisfaction through its “Lifetime Warranty Plus” on all Platinum Stock Products sold by PCB and through its limited warranties on all other PCB Stock, Standard and Special products. Due to the sophisticated nature of our sensors and associated instrumentation, **field servicing and repair is not recommended and, if attempted, will void the factory warranty.**

Beyond routine calibration and battery replacements where applicable, our products require no user maintenance. Clean electrical connectors, housings, and mounting surfaces with solutions and techniques that will not harm the material of construction. Observe caution when using liquids near devices that are not hermetically sealed. Such devices should only be wiped with a dampened cloth—never saturated or submerged.

In the event that equipment becomes damaged or ceases to operate, our Application Engineers are here to support your troubleshooting efforts 24 hours a day, 7 days a week. Call or email with model and serial number as well as a brief description of the problem.

Calibration

Routine calibration of sensors and associated instrumentation is necessary to maintain measurement accuracy. We recommend calibrating on an annual basis, after exposure to any extreme environmental influence, or prior to any critical test.

PCB Piezotronics is an ISO-9001 certified company whose calibration services are accredited by A2LA to ISO/IEC 17025, with full traceability to SI through N.I.S.T. In addition to our standard calibration services, we also offer specialized tests, including: sensitivity at elevated or cryogenic temperatures, phase response, extended high or low frequency response, extended range, leak testing, hydrostatic pressure testing, and others. For more information, contact your local PCB Piezotronics distributor, sales representative, or factory customer service representative.

Returning Equipment

If factory repair is required, our representatives will provide you with a Return Material Authorization (RMA) number, which we use to reference any information you have already provided and expedite the repair process. This number should be clearly marked on the outside of all returned package(s) and on any packing list(s) accompanying the shipment.

Contact Information

PCB Piezotronics, Inc.
3425 Walden Ave.
Depew, NY14043 USA
Toll-free: (800) 828-8840
24-hour SensorLine: (716) 684-0001
General inquiries: info@pcb.com
Repair inquiries: rma@pcb.com

For a complete list of distributors, global offices and sales representatives, visit our website, www.pcb.com.

Safety Considerations

This product is intended for use by qualified personnel who recognize shock hazards and are familiar with the precautions required to avoid injury. While our equipment is designed with user safety in mind, the protection provided by the equipment may be impaired if equipment is used in a manner not specified by this manual.

Discontinue use and contact our 24-Hour Sensorline if:

- Assistance is needed to safely operate equipment
- Damage is visible or suspected
- Equipment fails or malfunctions

For complete equipment ratings, refer to the enclosed specification sheet for your product.

Definition of Terms and Symbols

The following symbols may be used in this manual:



DANGER

Indicates an immediate hazardous situation, which, if not avoided, may result in death or serious injury.

**CAUTION**

Refers to hazards that could damage the instrument.

**NOTE**

Indicates tips, recommendations and important information. The notes simplify processes and contain additional information on particular operating steps.

The following symbols may be found on the equipment described in this manual:



This symbol on the unit indicates that high voltage may be present. Use standard safety precautions to avoid personal contact with this voltage.



This symbol on the unit indicates that the user should refer to the operating instructions located in the manual.



This symbol indicates safety, earth ground.



PCB工业监视和测量设备 - 中国RoHS2公布表

PCB Industrial Monitoring and Measuring Equipment - China RoHS 2 Disclosure Table

部件名称	有害物质					
	铅 (Pb)	汞 (Hg)	镉 (Cd)	六价铬 (Cr(VI))	多溴联苯 (PBB)	多溴二苯醚 (PBDE)
住房	0	0	0	0	0	0
PCB板	X	0	0	0	0	0
电气连接器	0	0	0	0	0	0
压电晶体	X	0	0	0	0	0
环氧	0	0	0	0	0	0
铁氟龙	0	0	0	0	0	0
电子	0	0	0	0	0	0
厚膜基板	0	0	X	0	0	0
电线	0	0	0	0	0	0
电缆	X	0	0	0	0	0
塑料	0	0	0	0	0	0
焊接	X	0	0	0	0	0
铜合金/黄铜	X	0	0	0	0	0
本表格依据 SJ/T 11364 的规定编制。						
0：表示该有害物质在该部件所有均质材料中的含量均在 GB/T 26572 规定的限量要求以下。						
X：表示该有害物质至少在该部件的某一均质材料中的含量超出 GB/T 26572 规定的限量要求。						
铅是欧洲RoHS指令2011/65/ EU附件三和附件四目前由于允许的豁免。						

CHINA RoHS COMPLIANCE

Component Name	Hazardous Substances					
	Lead (Pb)	Mercury (Hg)	Cadmium (Cd)	Chromium VI Compounds (Cr(VI))	Polybrominated Biphenyls (PBB)	Polybrominated Diphenyl Ethers (PBDE)
Housing	O	O	O	O	O	O
PCB Board	X	O	O	O	O	O
Electrical Connectors	O	O	O	O	O	O
Piezoelectric Crystals	X	O	O	O	O	O
Epoxy	O	O	O	O	O	O
Teflon	O	O	O	O	O	O
Electronics	O	O	O	O	O	O
Thick Film Substrate	O	O	X	O	O	O
Wires	O	O	O	O	O	O
Cables	X	O	O	O	O	O
Plastic	O	O	O	O	O	O
Solder	X	O	O	O	O	O
Copper Alloy/Brass	X	O	O	O	O	O

This table is prepared in accordance with the provisions of SJ/T 11364.

O: Indicates that said hazardous substance contained in all of the homogeneous materials for this part is below the limit requirement of GB/T 26572.

X: Indicates that said hazardous substance contained in at least one of the homogeneous materials for this part is above the limit requirement of GB/T 26572.

Lead is present due to allowed exemption in Annex III or Annex IV of the European RoHS Directive 2011/65/EU.

**OPERATING GUIDE
DYNAMIC (CRYOGENIC)
ICP® PRESSURE SENSORS
MODELS 102B10, B11, B13, B14**

1.0 DESCRIPTION

This sensor series consists of a Model 112A quartz pressure element coupled to a special MOSFET amplifier circuit to permit operation at cryogenic temperatures.

Cryogenic sensors use special electronics that have some characteristics differing from standard designs.

Polarity of the output signal is positive-going for increasing pressure.

2.0 INSTALLATION

Refer to installation drawing for mounting hole preparation. The outer housing of the thread adaptor is ground isolated from the sensing element.

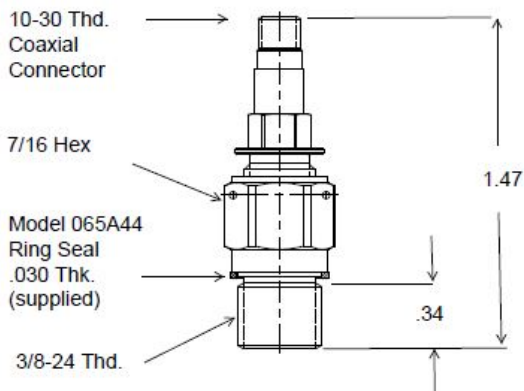

Series 102B10: Cryogenic Pressure Sensor

Prepare mounting ports in accordance with the installation drawing for the specific model, paying particular attention to sealing surfaces. These surfaces must be smooth and free from chatter marks, nicks and other irregularities which could prevent a pressure-tight seal.

Seals are provided with each sensor and should always be used. Extra seals for all standard models are in stock at the factory. It is recommended to replace the seals every time the sensor is re-installed.

Although these low-impedance sensors are not affected by moisture, in extreme environments such as cryogenic, it is advisable to protect cable connections with shrink tubing. Low-noise cable

(003A) is not necessary. Model 070A09 solder connector adaptor permits the use of ordinary two-wire cable.

3.0 OPERATION

These sensors are operated like standard ICP® sensors.

For general laboratory-type use, either Model 480C02 battery-powered signal conditioner or Model 482A06 line-powered signal conditioner is recommended for use with Cryogenic Sensors. Both Models provide 2 mA constant current to power the sensor electronics.

Other standard signal conditioners Series 481A, 482A, and 483A may also be used, provided the current is adjusted to 2 mA. All above Models include a bias de-coupling capacitor in series with the output connector.

For telemetry applications, Model 495A signal conditioner provides band pass filtering, adjustable gain, bias and limiting.

4.0 CALIBRATION

Because of the relatively short time constants of these sensors (see specification sheet at the front of this manual), only dynamic calibration methods can be used.

5.0 MAINTENANCE

Because of the miniature size and built-in electronics of these units, field maintenance is not recommended.

**OPERATING GUIDE
DYNAMIC (CRYOGENIC)
ICP[®] PRESSURE SENSORS
MODELS 102B10, B11, B13, B14**

6.0 CAUTION

The FET amplifier used in these sensors is a special low-noise device with gate breakdown voltage of 125 volts.

This voltage rating can be exceeded by either imposing a high-pressure step or a fast-rising pressure ramp to the diaphragm in excess of the rating for the sensor.

Slowly applied or released static pressure levels, within the mechanical capability of the sensor, are not dangerous since the charge generated by the quartz element has time to leak off through the FET bias resistor.

It is important to note that the following two pressure ratings are involved:

1. Maximum total pressure (mechanical consideration).
2. Maximum step pressure (electrical consideration).

NOTE: To avoid damage to the sensor, limit pressure application to maximum values on specification sheet at the front of this manual.

The maximum step pressure may be exceeded up to the maximum total pressure level provided the total pressure (rise or fall) takes place.

	ENGLISH	SI
Performance		
Measurement Range(for ±5V output)	10 kpsi	68,950 kPa
Useful Overrange	15 kpsi	103,425 kPa
Sensitivity(± 15 %)	0.5 mV/psi	0.073 mV/kPa
Maximum Pressure(static)	15 kpsi	103,425 kPa
Resolution	200 mpsi	1.4 kPa [1]
Resonant Frequency	≥ 250 kHz	≥ 250 kHz
Rise Time	≤ 2.0 μ sec	≤ 2.0 μ sec
Low Frequency Response(- 5 %)	0.1 Hz	0.1 Hz
Non-Linearity	< 1 % FS	< 1 % FS [2]
Environmental		
Acceleration Sensitivity	≤ 0.002 psi/g	≤ 0.0014 kPa/(m/s ²)
Temperature Range(Operating)	-320 to +212 °F	-196 to +100 °C
Temperature Coefficient of Sensitivity	≤ 0.06 %/°F	≤ 0.108 %/°C
Maximum Shock	20,000 g pk	196,140 m/s ² pk
Electrical		
Output Polarity(Positive Pressure)	Positive	Positive
Discharge Time Constant(at room temp)	≥ 5 sec	≥ 5 sec
Excitation Voltage	20 to 30 VDC	20 to 30 VDC
Constant Current Excitation	2 to 20 mA	2 to 20 mA
Output Impedance	< 100 Ohm	< 100 Ohm
Output Bias Voltage	9 to 13 VDC	9 to 13 VDC
Physical		
Sensing Element	Quartz	Quartz
Housing Material	Stainless Steel	Stainless Steel
Diaphragm	316L Stainless Steel	316L Stainless Steel
Sealing	Welded Hermetic	Welded Hermetic
Electrical Connector	10-32 Coaxial Jack	10-32 Coaxial Jack
Weight	0.388 oz	11.00 gm

OPTIONAL VERSIONS

Optional versions have identical specifications and accessories as listed for the standard model except where noted below. More than one option may be used.

M - Metric Mount
Supplied Accessory: Model 065A34 Seal ring 0.435" OD x 0.397" ID x 0.030" Cu (3)

NOTES:

[1]Typical.
[2]Zero-based, least-squares, straight line method.
[3]See PCB Declaration of Conformance PS023 for details.

SUPPLIED ACCESSORIES:

Model 065A34 Seal ring 0.435" OD x 0.397" ID x 0.030" Cu (3)
Model 065A44 Seal ring 0.435" OD x 0.377" ID x 0.030" thk Cu (3)

Entered: ND	Engineer: MP	Sales: MV	Approved: RPF	Spec Number:
Date: 03/04/2022	Date: 03/04/2022	Date: 03/04/2022	Date: 03/04/2022	74948

PCB PIEZOTRONICS
AN AMPHENOL COMPANY

Phone: 716-684-0001
Fax: 716-684-0987
E-Mail: info@pcb.com

3425 Walden Avenue, Depew, NY 14043



All specifications are at room temperature unless otherwise specified.
In the interest of constant product improvement, we reserve the right to change specifications without notice.
ICP® is a registered trademark of PCB Piezotronics, Inc.



Model 14907-03

Installation and Operating Manual

**For assistance with the operation of this product,
contact the PCB Piezotronics, Inc.**

Toll-free: 716-684-0001

24-hour SensorLine: 716-684-0001

Fax: 716-684-0987

E-mail: info@pcb.com

Web: www.pcb.com



Repair and Maintenance

PCB guarantees Total Customer Satisfaction through its “Lifetime Warranty Plus” on all Platinum Stock Products sold by PCB and through its limited warranties on all other PCB Stock, Standard and Special products. Due to the sophisticated nature of our sensors and associated instrumentation, **field servicing and repair is not recommended and, if attempted, will void the factory warranty.**

Beyond routine calibration and battery replacements where applicable, our products require no user maintenance. Clean electrical connectors, housings, and mounting surfaces with solutions and techniques that will not harm the material of construction. Observe caution when using liquids near devices that are not hermetically sealed. Such devices should only be wiped with a dampened cloth—never saturated or submerged.

In the event that equipment becomes damaged or ceases to operate, our Application Engineers are here to support your troubleshooting efforts 24 hours a day, 7 days a week. Call or email with model and serial number as well as a brief description of the problem.

Calibration

Routine calibration of sensors and associated instrumentation is necessary to maintain measurement accuracy. We recommend calibrating on an annual basis, after exposure to any extreme environmental influence, or prior to any critical test.

PCB Piezotronics is an ISO-9001 certified company whose calibration services are accredited by A2LA to ISO/IEC 17025, with full traceability to SI through N.I.S.T. In addition to our standard calibration services, we also offer specialized tests, including: sensitivity at elevated or cryogenic temperatures, phase response, extended high or low frequency response, extended range, leak testing, hydrostatic pressure testing, and others. For more information, contact your local PCB Piezotronics distributor, sales representative, or factory customer service representative.

Returning Equipment

If factory repair is required, our representatives will provide you with a Return Material Authorization (RMA) number, which we use to reference any information you have already provided and expedite the repair process. This number should be clearly marked on the outside of all returned package(s) and on any packing list(s) accompanying the shipment.

Contact Information

PCB Piezotronics, Inc.
3425 Walden Ave.
Depew, NY14043 USA
Toll-free: (800) 828-8840
24-hour SensorLine: (716) 684-0001
General inquiries: info@pcb.com
Repair inquiries: rma@pcb.com

For a complete list of distributors, global offices and sales representatives, visit our website, www.pcb.com.

Safety Considerations

This product is intended for use by qualified personnel who recognize shock hazards and are familiar with the precautions required to avoid injury. While our equipment is designed with user safety in mind, the protection provided by the equipment may be impaired if equipment is used in a manner not specified by this manual.

Discontinue use and contact our 24-Hour Sensorline if:

- Assistance is needed to safely operate equipment
- Damage is visible or suspected
- Equipment fails or malfunctions

For complete equipment ratings, refer to the enclosed specification sheet for your product.

Definition of Terms and Symbols

The following symbols may be used in this manual:



DANGER

Indicates an immediate hazardous situation, which, if not avoided, may result in death or serious injury.

**CAUTION**

Refers to hazards that could damage the instrument.

**NOTE**

Indicates tips, recommendations and important information. The notes simplify processes and contain additional information on particular operating steps.

The following symbols may be found on the equipment described in this manual:



This symbol on the unit indicates that high voltage may be present. Use standard safety precautions to avoid personal contact with this voltage.



This symbol on the unit indicates that the user should refer to the operating instructions located in the manual.



This symbol indicates safety, earth ground.



PCB工业监视和测量设备 - 中国RoHS2公布表

PCB Industrial Monitoring and Measuring Equipment - China RoHS 2 Disclosure Table

部件名称	有害物质					
	铅 (Pb)	汞 (Hg)	镉 (Cd)	六价铬 (Cr(VI))	多溴联苯 (PBB)	多溴二苯醚 (PBDE)
住房	0	0	0	0	0	0
PCB板	X	0	0	0	0	0
电气连接器	0	0	0	0	0	0
压电晶体	X	0	0	0	0	0
环氧	0	0	0	0	0	0
铁氟龙	0	0	0	0	0	0
电子	0	0	0	0	0	0
厚膜基板	0	0	X	0	0	0
电线	0	0	0	0	0	0
电缆	X	0	0	0	0	0
塑料	0	0	0	0	0	0
焊接	X	0	0	0	0	0
铜合金/黄铜	X	0	0	0	0	0
本表格依据 SJ/T 11364 的规定编制。						
0：表示该有害物质在该部件所有均质材料中的含量均在 GB/T 26572 规定的限量要求以下。						
X：表示该有害物质至少在该部件的某一均质材料中的含量超出 GB/T 26572 规定的限量要求。						
铅是欧洲RoHS指令2011/65/ EU附件三和附件四目前由于允许的豁免。						

CHINA RoHS COMPLIANCE

Component Name	Hazardous Substances					
	Lead (Pb)	Mercury (Hg)	Cadmium (Cd)	Chromium VI Compounds (Cr(VI))	Polybrominated Biphenyls (PBB)	Polybrominated Diphenyl Ethers (PBDE)
Housing	O	O	O	O	O	O
PCB Board	X	O	O	O	O	O
Electrical Connectors	O	O	O	O	O	O
Piezoelectric Crystals	X	O	O	O	O	O
Epoxy	O	O	O	O	O	O
Teflon	O	O	O	O	O	O
Electronics	O	O	O	O	O	O
Thick Film Substrate	O	O	X	O	O	O
Wires	O	O	O	O	O	O
Cables	X	O	O	O	O	O
Plastic	O	O	O	O	O	O
Solder	X	O	O	O	O	O
Copper Alloy/Brass	X	O	O	O	O	O

This table is prepared in accordance with the provisions of SJ/T 11364.

O: Indicates that said hazardous substance contained in all of the homogeneous materials for this part is below the limit requirement of GB/T 26572.

X: Indicates that said hazardous substance contained in at least one of the homogeneous materials for this part is above the limit requirement of GB/T 26572.

Lead is present due to allowed exemption in Annex III or Annex IV of the European RoHS Directive 2011/65/EU.

Performance	ENGLISH	SI	
Sensitivity(+/- 15 %)	1.1 pC/psi	0.16 pC/kPa	
Measurement Range	10,000 psi	6,896 kPa	[1]
Cycle Pressure	16,000 psi	110,000 kPa	
Maximum Pressure(Total)	15,000 psi	103,421 kPa	
Resonant Frequency	≥ 250 kHz	≥ 250 kHz	
Rise Time(Reflected)	≤ 2.0 μ sec	≤ 2.0 μ sec	
Non-Linearity	≤ 1.0 % FS	≤ 1.0 % FS	[1]
Environmental			
Acceleration Sensitivity(Final)	≤ 0.002 psi/g	≤ 0.0014 kPa/(m/s ²)	
Temperature Range(Operating)	-320 to +212 °F	-196 to +100 °C	
Temperature Coefficient of Sensitivity	≤ 0.06 %/°F	≤ 0.11 %/°C	
Maximum Flash Temperature	3,000 °F	1,650 °C	
Maximum Vibration	2,000 g pk	19,613 m/s ² pk	
Maximum Shock	20,000 g pk	196,133 m/s ² pk	
Electrical			
Output Polarity(Positive)	Positive	Positive	
Capacitance	17 to 24 pF	17 to 24 pF	
Insulation Resistance(Room Temp.)	≥ 10 ¹² Ohm	≥ 10 ¹² Ohm	
Physical			
Sensing Element	Quartz	Quartz	
Sensing Geometry	Compression	Compression	
Housing Material	304L/316L Stainless Steel	304L/316L Stainless Steel	
Diaphragm	316L Stainless Steel	316L Stainless Steel	
Sealing	Epoxy	Epoxy	
Electrical Connector	10-32 Coaxial Plug	10-32 Coaxial Plug	
Mounting Torque	23 to 35 in-lb	26.4 to 40.3 kg-cm	[2]

OPTIONAL VERSIONS

Optional versions have identical specifications and accessories as listed for the standard model except where noted below. More than one option may be used.

NOTES:
 [1] Calibration steps: 10,000 psi, 5,000 psi, 2,000 psi, 1,000 psi, 500 psi, 200 psi, 100 psi, 50 psi
 [2] When used with standard mounting hardware.

--	--	--	--

Entered: LK	Engineer: NJL	Sales:	Approved: RPF	Spec Number:
Date: 07/13/2020	Date: 07/13/2020	Date:	Date: 07/13/2020	72684

PCB Internal Use Only

For Internal Use Only

All specifications are at room temperature unless otherwise specified.
 In the interest of constant product improvement, we reserve the right to change specifications without notice.



Model 061A01

Mounting adaptor, 3/8-24 external thd to 5/16-24 internal thd, 17-4 SS (for Series 111, 112 & 113)

Installation and Operating Manual

**For assistance with the operation of this product,
contact the PCB Piezotronics, Inc.**

Toll-free: 716-684-0001

24-hour SensorLine: 716-684-0001

Fax: 716-684-0987

E-mail: info@pcb.com

Web: www.pcb.com



Repair and Maintenance

PCB guarantees Total Customer Satisfaction through its “Lifetime Warranty Plus” on all Platinum Stock Products sold by PCB and through its limited warranties on all other PCB Stock, Standard and Special products. Due to the sophisticated nature of our sensors and associated instrumentation, **field servicing and repair is not recommended and, if attempted, will void the factory warranty.**

Beyond routine calibration and battery replacements where applicable, our products require no user maintenance. Clean electrical connectors, housings, and mounting surfaces with solutions and techniques that will not harm the material of construction. Observe caution when using liquids near devices that are not hermetically sealed. Such devices should only be wiped with a dampened cloth—never saturated or submerged.

In the event that equipment becomes damaged or ceases to operate, our Application Engineers are here to support your troubleshooting efforts 24 hours a day, 7 days a week. Call or email with model and serial number as well as a brief description of the problem.

Calibration

Routine calibration of sensors and associated instrumentation is necessary to maintain measurement accuracy. We recommend calibrating on an annual basis, after exposure to any extreme environmental influence, or prior to any critical test.

PCB Piezotronics is an ISO-9001 certified company whose calibration services are accredited by A2LA to ISO/IEC 17025, with full traceability to SI through N.I.S.T. In addition to our standard calibration services, we also offer specialized tests, including: sensitivity at elevated or cryogenic temperatures, phase response, extended high or low frequency response, extended range, leak testing, hydrostatic pressure testing, and others. For more information, contact your local PCB Piezotronics distributor, sales representative, or factory customer service representative.

Returning Equipment

If factory repair is required, our representatives will provide you with a Return Material Authorization (RMA) number, which we use to reference any information you have already provided and expedite the repair process. This number should be clearly marked on the outside of all returned package(s) and on any packing list(s) accompanying the shipment.

Contact Information

PCB Piezotronics, Inc.
3425 Walden Ave.
Depew, NY14043 USA
Toll-free: (800) 828-8840
24-hour SensorLine: (716) 684-0001
General inquiries: info@pcb.com
Repair inquiries: rma@pcb.com

For a complete list of distributors, global offices and sales representatives, visit our website, www.pcb.com.

Safety Considerations

This product is intended for use by qualified personnel who recognize shock hazards and are familiar with the precautions required to avoid injury. While our equipment is designed with user safety in mind, the protection provided by the equipment may be impaired if equipment is used in a manner not specified by this manual.

Discontinue use and contact our 24-Hour Sensorline if:

- Assistance is needed to safely operate equipment
- Damage is visible or suspected
- Equipment fails or malfunctions

For complete equipment ratings, refer to the enclosed specification sheet for your product.

Definition of Terms and Symbols

The following symbols may be used in this manual:



DANGER

Indicates an immediate hazardous situation, which, if not avoided, may result in death or serious injury.

**CAUTION**

Refers to hazards that could damage the instrument.

**NOTE**

Indicates tips, recommendations and important information. The notes simplify processes and contain additional information on particular operating steps.

The following symbols may be found on the equipment described in this manual:



This symbol on the unit indicates that high voltage may be present. Use standard safety precautions to avoid personal contact with this voltage.



This symbol on the unit indicates that the user should refer to the operating instructions located in the manual.



This symbol indicates safety, earth ground.



PCB工业监视和测量设备 - 中国RoHS2公布表

PCB Industrial Monitoring and Measuring Equipment - China RoHS 2 Disclosure Table

部件名称	有害物质					
	铅 (Pb)	汞 (Hg)	镉 (Cd)	六价铬 (Cr(VI))	多溴联苯 (PBB)	多溴二苯醚 (PBDE)
住房	0	0	0	0	0	0
PCB板	X	0	0	0	0	0
电气连接器	0	0	0	0	0	0
压电晶体	X	0	0	0	0	0
环氧	0	0	0	0	0	0
铁氟龙	0	0	0	0	0	0
电子	0	0	0	0	0	0
厚膜基板	0	0	X	0	0	0
电线	0	0	0	0	0	0
电缆	X	0	0	0	0	0
塑料	0	0	0	0	0	0
焊接	X	0	0	0	0	0
铜合金/黄铜	X	0	0	0	0	0
本表格依据 SJ/T 11364 的规定编制。						
0：表示该有害物质在该部件所有均质材料中的含量均在 GB/T 26572 规定的限量要求以下。						
X：表示该有害物质至少在该部件的某一均质材料中的含量超出 GB/T 26572 规定的限量要求。						
铅是欧洲RoHS指令2011/65/ EU附件三和附件四目前由于允许的豁免。						

CHINA RoHS COMPLIANCE

Component Name	Hazardous Substances					
	Lead (Pb)	Mercury (Hg)	Cadmium (Cd)	Chromium VI Compounds (Cr(VI))	Polybrominated Biphenyls (PBB)	Polybrominated Diphenyl Ethers (PBDE)
Housing	O	O	O	O	O	O
PCB Board	X	O	O	O	O	O
Electrical Connectors	O	O	O	O	O	O
Piezoelectric Crystals	X	O	O	O	O	O
Epoxy	O	O	O	O	O	O
Teflon	O	O	O	O	O	O
Electronics	O	O	O	O	O	O
Thick Film Substrate	O	O	X	O	O	O
Wires	O	O	O	O	O	O
Cables	X	O	O	O	O	O
Plastic	O	O	O	O	O	O
Solder	X	O	O	O	O	O
Copper Alloy/Brass	X	O	O	O	O	O

This table is prepared in accordance with the provisions of SJ/T 11364.

O: Indicates that said hazardous substance contained in all of the homogeneous materials for this part is below the limit requirement of GB/T 26572.

X: Indicates that said hazardous substance contained in at least one of the homogeneous materials for this part is above the limit requirement of GB/T 26572.

Lead is present due to allowed exemption in Annex III or Annex IV of the European RoHS Directive 2011/65/EU.

061-1010-90

PCB Piezotronics Inc. claims proprietary rights in the information disclosed hereon. Neither it nor any reproduction thereof will be disclosed to others without the written consent of PCB Piezotronics Inc.

REVISIONS		
REV	DESCRIPTION	DIN
E	UPDATED NOTES & ADDED DETAIL VIEW	53692

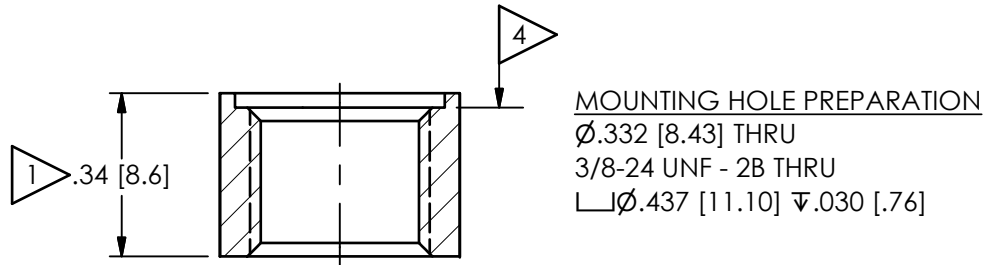
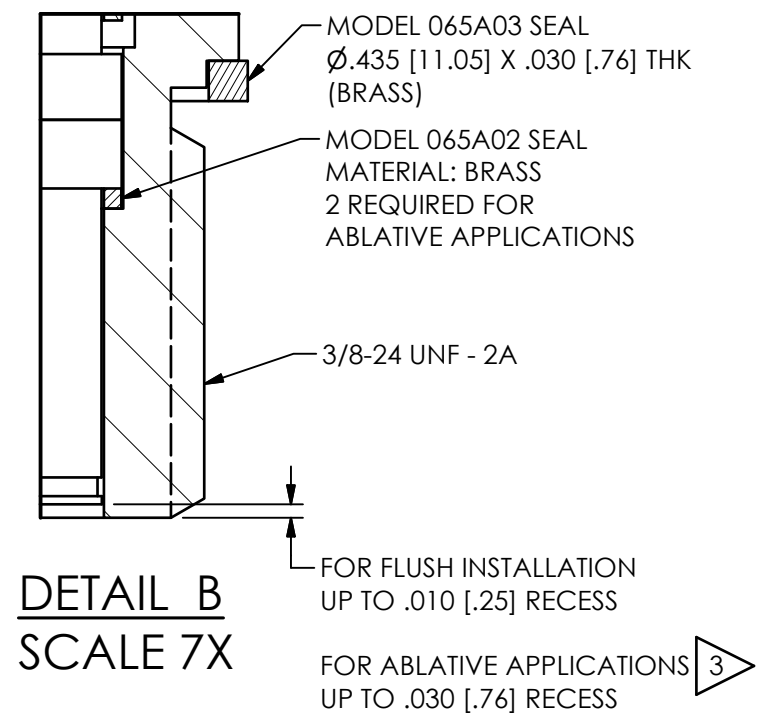
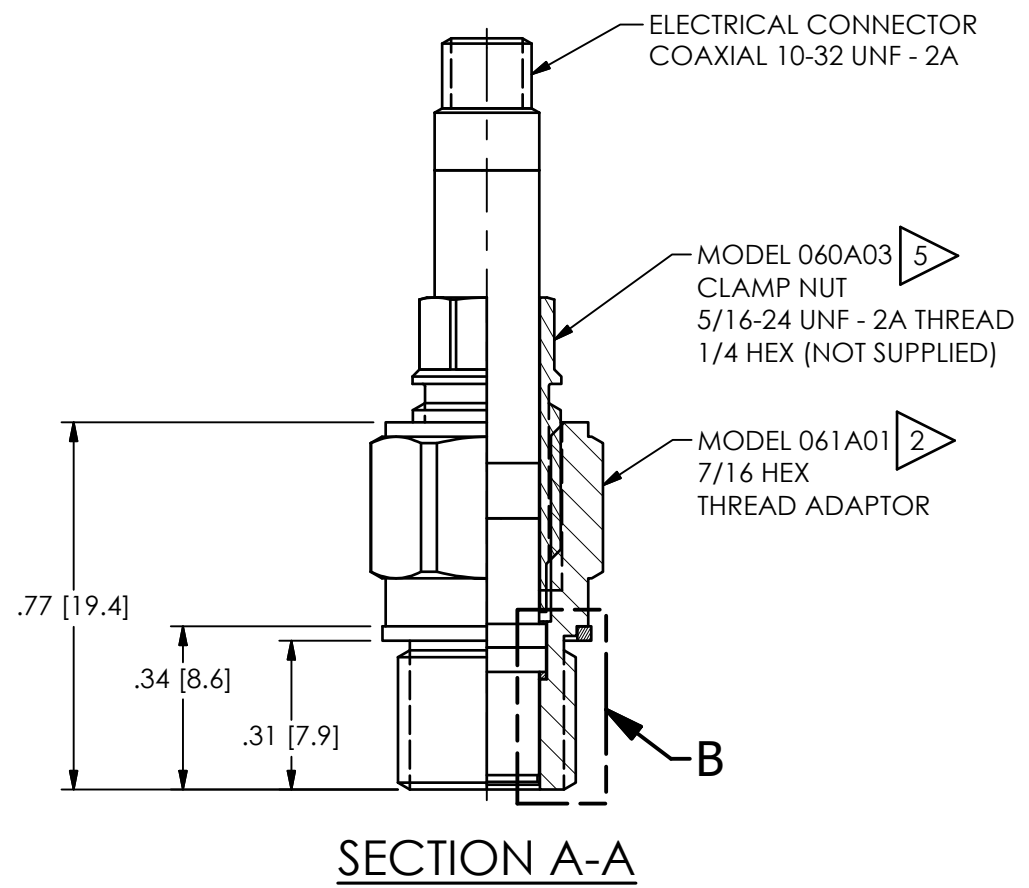
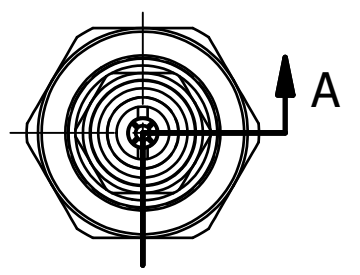

- 5 MOUNTING TORQUE ON 1/4 HEX, 25-35 IN-LBS [2.82-3.95 N-m]
- 4 SEAL SURFACE MUST BE FLAT AND FREE OF TOOL MARKS WITH A MIN SURFACE FINISH OF 63
- 3 RTV ABLATIVE COATING IS APPLIED TO THE DIAPHRAGM FOR FLASH TEMPERATURE PROTECTION, REPLACE WITH MOMENTIVE RTV106 ADHESIVE SEALANT BLACK VINYL ELECTRICIANS TAPE HAS ALSO BEEN FOUND TO BE AN EFFECTIVE ABLATIVE MATERIAL AS IS DC-4 SILICONE GREASE
- 2 MOUNTING TORQUE ON 7/16 HEX, 5-8 FT-LBS [6.78-10.85 N-m]
- 1 ABOVE INSTALLATION SHOWN FOR WALL THICKNESS OF .34 [8.64], C'BORE THICKER WALLS Ø.75 [19.05] TO CLEAR 7/16 HEX AND ALLOW FOR SOCKET WRENCH

UNLESS OTHERWISE SPECIFIED TOLERANCES ARE:		DRAWN		CHECKED		ENGINEER		PCB PIEZOTRONICS AN AMPHENOL COMPANY	
DIMENSIONS IN INCHES		NJF	03/17/23	JJF	03/17/23	RF	03/17/23		3425 WALDEN AVE. DEPEW, NY 14043 (716) 684-0001 E-MAIL: sales@pcb.com
DECIMALS XX ±.01 XXX ±.005		DIMENSIONS IN MILLIMETERS [IN BRACKETS] DECIMALS X ±0.3 XX ±0.13		TITLE				CODE IDENT. NO. 52681	DWG. NO. 061-1010-90
ANGLES ± 2 DEGREES		CABLE TOLERANCES IN ENGLISH		INSTALLATION DRAWING				SCALE: 2.5X	SHEET 1 OF 1
CABLE TOLERANCES IN METRIC		FILLETS AND RADII .003 - .005		MODEL 061A01 THREAD ADAPTOR					
1" ≤ LENGTH < 1' = +1' / - 0		FILLETS AND RADII 0.07 - 0.13							
1' ≤ LENGTH < 5' = +2' / - 0									
5' ≤ LENGTH < 100' = +6' / - 0									
100' ≤ LENGTH = +1' / - 0									
2.54cm ≤ LENGTH < 30.5cm = +2.54cm / - 0									
30.5cm ≤ LENGTH < 1.5m = +5.1cm / - 0									
1.5m ≤ LENGTH < 30.5m = +15.2cm / - 0									
30.5m ≤ LENGTH = +30.5cm / - 0									



Model 102B13

Cryogenic ICP® pressure sensor, 10k psi, 0.5 mV/psi, 3/8-24 mtg thd, ground isolated with safety wire holes

Installation and Operating Manual

This manual contains the 061A01, 14907-03 installation and operating manuals that comprise a Model 102B13 Cryogenic ICP® pressure sensor, 10k psi, 0.5 mV/psi, 3/8-24 mtg thd, ground isolated with safety wire holes kit.

**For assistance with the operation of this product,
contact the PCB Piezotronics, Inc.**

**Toll-free: 716-684-0001
24-hour SensorLine: 716-684-0001
Fax: 716-684-0987
E-mail: info@pcb.com
Web: www.pcb.com**



Repair and Maintenance

PCB guarantees Total Customer Satisfaction through its “Lifetime Warranty Plus” on all Platinum Stock Products sold by PCB and through its limited warranties on all other PCB Stock, Standard and Special products. Due to the sophisticated nature of our sensors and associated instrumentation, **field servicing and repair is not recommended and, if attempted, will void the factory warranty.**

Beyond routine calibration and battery replacements where applicable, our products require no user maintenance. Clean electrical connectors, housings, and mounting surfaces with solutions and techniques that will not harm the material of construction. Observe caution when using liquids near devices that are not hermetically sealed. Such devices should only be wiped with a dampened cloth—never saturated or submerged.

In the event that equipment becomes damaged or ceases to operate, our Application Engineers are here to support your troubleshooting efforts 24 hours a day, 7 days a week. Call or email with model and serial number as well as a brief description of the problem.

Calibration

Routine calibration of sensors and associated instrumentation is necessary to maintain measurement accuracy. We recommend calibrating on an annual basis, after exposure to any extreme environmental influence, or prior to any critical test.

PCB Piezotronics is an ISO-9001 certified company whose calibration services are accredited by A2LA to ISO/IEC 17025, with full traceability to SI through N.I.S.T. In addition to our standard calibration services, we also offer specialized tests, including: sensitivity at elevated or cryogenic temperatures, phase response, extended high or low frequency response, extended range, leak testing, hydrostatic pressure testing, and others. For more information, contact your local PCB Piezotronics distributor, sales representative, or factory customer service representative.

Returning Equipment

If factory repair is required, our representatives will provide you with a Return Material Authorization (RMA) number, which we use to reference any information you have already provided and expedite the repair process. This number should be clearly marked on the outside of all returned package(s) and on any packing list(s) accompanying the shipment.

Contact Information

PCB Piezotronics, Inc.
3425 Walden Ave.
Depew, NY14043 USA
Toll-free: (800) 828-8840
24-hour SensorLine: (716) 684-0001
General inquiries: info@pcb.com
Repair inquiries: rma@pcb.com

For a complete list of distributors, global offices and sales representatives, visit our website, www.pcb.com.

Safety Considerations

This product is intended for use by qualified personnel who recognize shock hazards and are familiar with the precautions required to avoid injury. While our equipment is designed with user safety in mind, the protection provided by the equipment may be impaired if equipment is used in a manner not specified by this manual.

Discontinue use and contact our 24-Hour Sensorline if:

- Assistance is needed to safely operate equipment
- Damage is visible or suspected
- Equipment fails or malfunctions

For complete equipment ratings, refer to the enclosed specification sheet for your product.

Definition of Terms and Symbols

The following symbols may be used in this manual:



DANGER

Indicates an immediate hazardous situation, which, if not avoided, may result in death or serious injury.

**CAUTION**

Refers to hazards that could damage the instrument.

**NOTE**

Indicates tips, recommendations and important information. The notes simplify processes and contain additional information on particular operating steps.

The following symbols may be found on the equipment described in this manual:



This symbol on the unit indicates that high voltage may be present. Use standard safety precautions to avoid personal contact with this voltage.



This symbol on the unit indicates that the user should refer to the operating instructions located in the manual.



This symbol indicates safety, earth ground.



PCB工业监视和测量设备 - 中国RoHS2公布表

PCB Industrial Monitoring and Measuring Equipment - China RoHS 2 Disclosure Table

部件名称	有害物质					
	铅 (Pb)	汞 (Hg)	镉 (Cd)	六价铬 (Cr(VI))	多溴联苯 (PBB)	多溴二苯醚 (PBDE)
住房	0	0	0	0	0	0
PCB板	X	0	0	0	0	0
电气连接器	0	0	0	0	0	0
压电晶体	X	0	0	0	0	0
环氧	0	0	0	0	0	0
铁氟龙	0	0	0	0	0	0
电子	0	0	0	0	0	0
厚膜基板	0	0	X	0	0	0
电线	0	0	0	0	0	0
电缆	X	0	0	0	0	0
塑料	0	0	0	0	0	0
焊接	X	0	0	0	0	0
铜合金/黄铜	X	0	0	0	0	0
本表格依据 SJ/T 11364 的规定编制。						
0：表示该有害物质在该部件所有均质材料中的含量均在 GB/T 26572 规定的限量要求以下。						
X：表示该有害物质至少在该部件的某一均质材料中的含量超出 GB/T 26572 规定的限量要求。						
铅是欧洲RoHS指令2011/65/ EU附件三和附件四目前由于允许的豁免。						

CHINA RoHS COMPLIANCE

Component Name	Hazardous Substances					
	Lead (Pb)	Mercury (Hg)	Cadmium (Cd)	Chromium VI Compounds (Cr(VI))	Polybrominated Biphenyls (PBB)	Polybrominated Diphenyl Ethers (PBDE)
Housing	O	O	O	O	O	O
PCB Board	X	O	O	O	O	O
Electrical Connectors	O	O	O	O	O	O
Piezoelectric Crystals	X	O	O	O	O	O
Epoxy	O	O	O	O	O	O
Teflon	O	O	O	O	O	O
Electronics	O	O	O	O	O	O
Thick Film Substrate	O	O	X	O	O	O
Wires	O	O	O	O	O	O
Cables	X	O	O	O	O	O
Plastic	O	O	O	O	O	O
Solder	X	O	O	O	O	O
Copper Alloy/Brass	X	O	O	O	O	O

This table is prepared in accordance with the provisions of SJ/T 11364.

O: Indicates that said hazardous substance contained in all of the homogeneous materials for this part is below the limit requirement of GB/T 26572.

X: Indicates that said hazardous substance contained in at least one of the homogeneous materials for this part is above the limit requirement of GB/T 26572.

Lead is present due to allowed exemption in Annex III or Annex IV of the European RoHS Directive 2011/65/EU.

PCB Piezotronics Inc. claims proprietary rights in the information disclosed hereon. Neither it nor any reproduction thereof will be disclosed to others without the written consent of PCB Piezotronics Inc.

70414

REVISIONS		
REV	DESCRIPTION	DIN
A	UPDATED TORQUE NOTE	52229

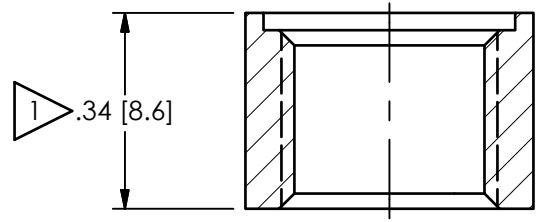
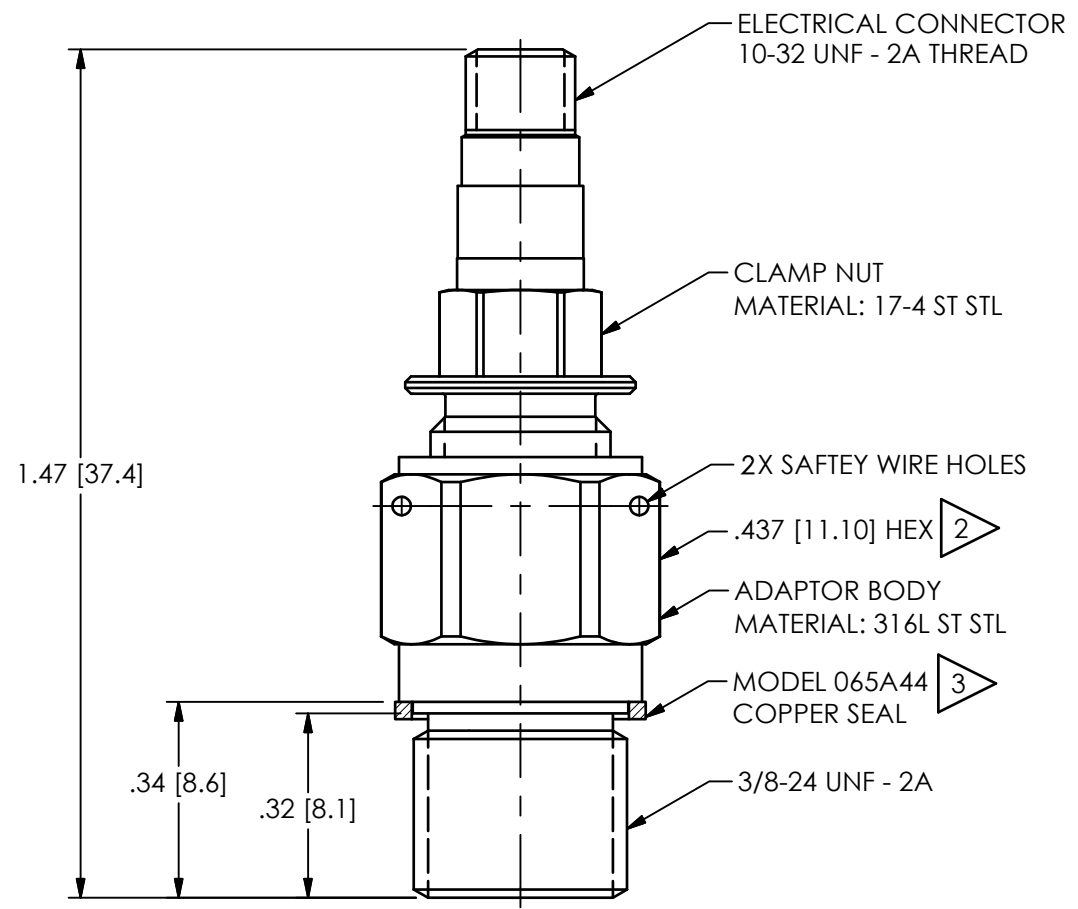
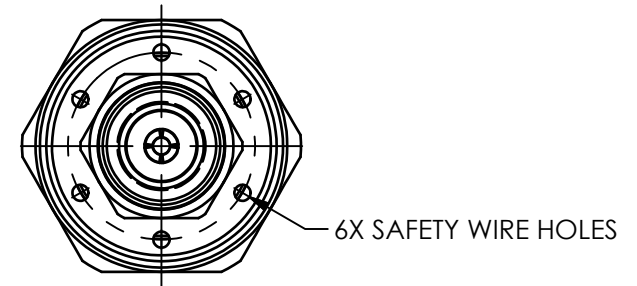

MOUNTING HOLE PREPARATION:
 \varnothing .332 [8.43] THRU
 \llcorner \varnothing .437 [11.10] ∇ .030 [.76]
 3/8-24 UNF-2B THRU

- 3 MODEL 065M29 ST STL SEAL AVAILABLE
- 2 MOUNTING TORQUE ON 7/16 HEX: 5 - 8 FT LBS [6.78 - 10.85 Nm] WITHOUT THREAD LUBRICANT
- 1 ABOVE INSTALLATION SHOWN FOR WALL THICKNESS OF .34 [8.6] THICK, \llcorner THICKER WALLS \varnothing .75 [19.0] TO CLEAR .437 [11.10] HEX AND ALLOW FOR SOCKET WRENCH

UNLESS OTHERWISE SPECIFIED TOLERANCES ARE:		DRAWN		CHECKED		ENGINEER			
DIMENSIONS IN INCHES	DIMENSIONS IN MILLIMETERS [IN BRACKETS]	JJF	10/27/21	JJF	10/27/21	MJP	10/27/21		
DECIMALS XX ±.01 XXX ±.005	DECIMALS X ±0.3 XX ±0.13	TITLE INSTALLATION DRAWING CRYOGENIC GROUND ISOLATED ICP® PRESSURE SENSOR							
ANGLES ± 2 DEGREES	ANGLES ± 2 DEGREES								
CABLE TOLERANCES IN ENGLISH 1' ≤ LENGTH < 1' = +1' / - 0 1' ≤ LENGTH < 5' = +2' / - 0 5' ≤ LENGTH < 100' = +6' / - 0 100' ≤ LENGTH = +1' / - 0	CABLE TOLERANCES IN METRIC 2.54cm ≤ LENGTH < 30.5cm = +2.54cm / - 0 30.5cm ≤ LENGTH < 1.5m = +5.1cm / - 0 1.5m ≤ LENGTH < 30.5m = +15.2cm / - 0 30.5m ≤ LENGTH = +30.5cm / - 0								
FILLETS AND RADII .003 - .005	FILLETS AND RADII 0.07 - 0.13								
		CODE IDENT. NO. 52681		DWG. NO. 70414		SCALE: 3X		SHEET 1 OF 1	