

108-1020-90

PCB Piezotronics Inc. claims proprietary rights in the information disclosed hereon. Neither it nor any reproduction thereof will be disclosed to others without the written consent of PCB Piezotronics Inc.

REVISIONS		
REV	DESCRIPTION	DIN
H	CORRECTED MOUNTING HOLES	51799

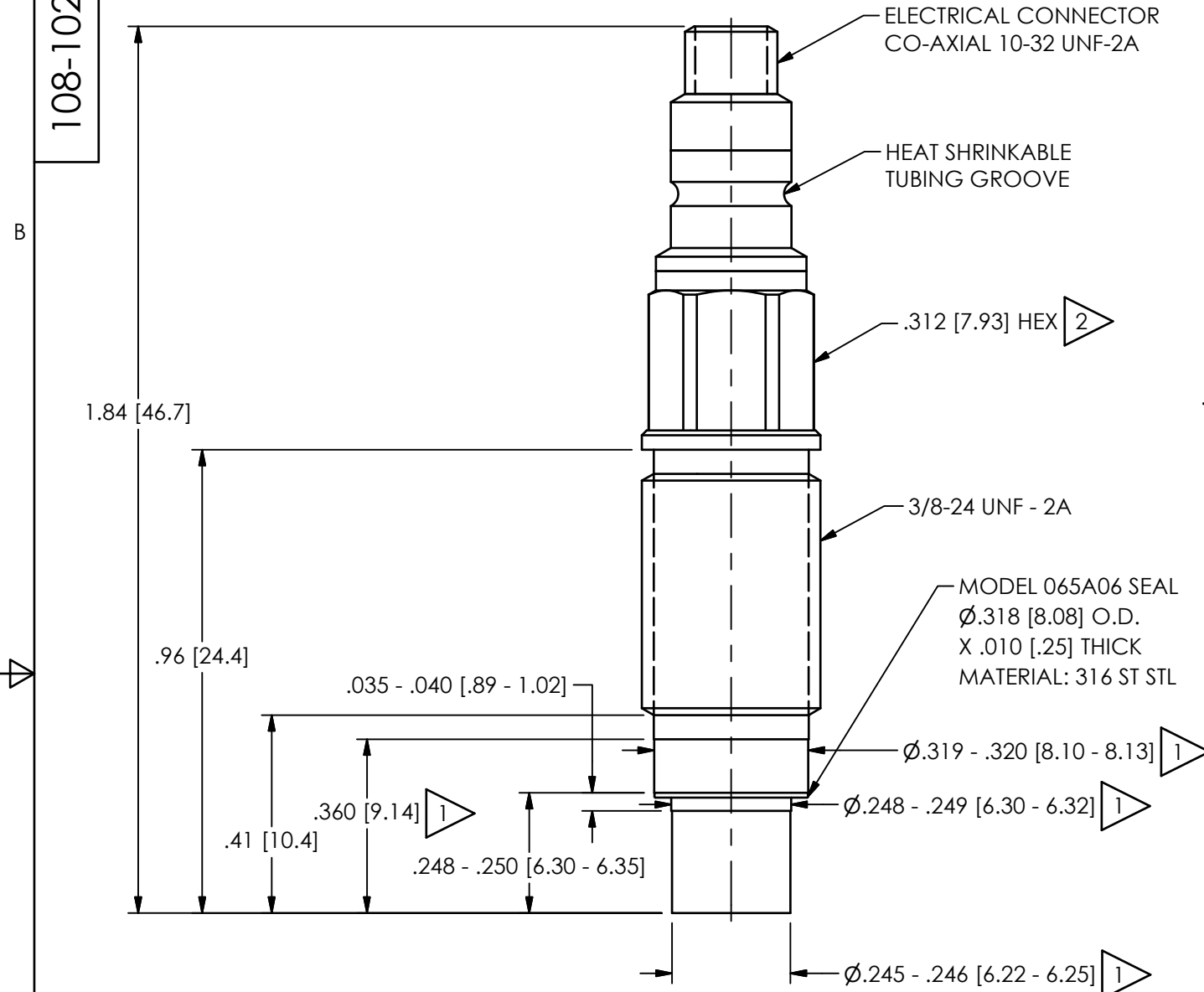

FLUSH INSTALLATION

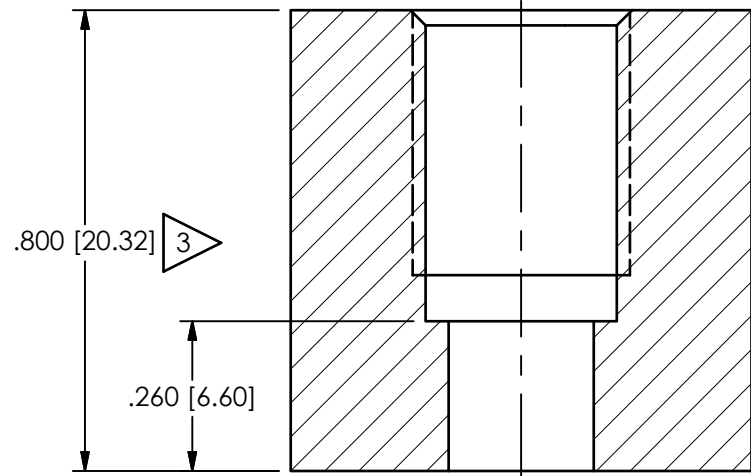

RECESSED INSTALLATION

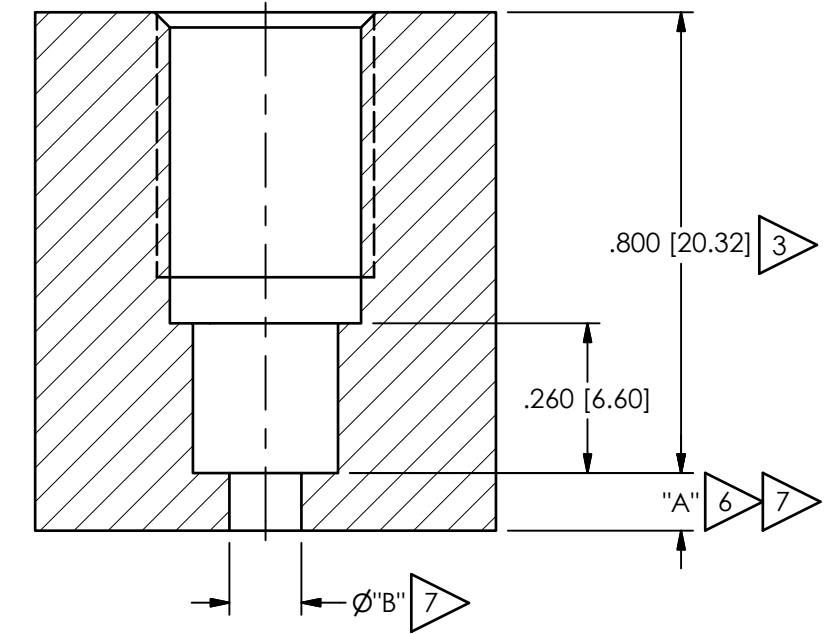

MOUNTING HOLE DIMENSIONS

- 3 5 Ø.252 ±.001 [6.40 ±.03] THRU
- 4 5 L Ø.332 ±.001 [8.43 ±.03] (▽.540 [13.72])
- 8 3/8-24 UNF-2B (▽.460 [11.68])

MOUNTING HOLE DIMENSIONS

- 3 5 Ø.252 ±.001 [6.40 ±.03] (▽.800 [20.32])
- 4 5 L Ø.332 ±.001 [8.43 ±.03] (▽.540 [13.72])
- 8 3/8-24 UNF-2B (▽.460 [11.68])

- 8 CAUTION: DO NOT TOUCH SEAL SURFACE WITH TAP WHEN TAPPING HOLE
- 7 DIMENSION "A" & "B" TO SUIT USER REQUIREMENTS
- 6 KEEP "A" AS SHORT AS POSSIBLE, SEE OPERATING GUIDE FOR OPTIMUM PASSAGE LENGTH
- 5 THESE DIAMETERS TO BE CONCENTRIC WITHIN .001 [.03] TIR
- 4 SEAL SURFACE SHOULD BE FLAT AND FREE OF TOOL MARKS WITH A MINIMUM FINISH OF 63 [1.6] FOR BEST RESULTS
- 3 DIMENSIONS SHOWN ARE FOR .800 [20.32] WALL THICKNESS. C'BORE FOR THICKER WALL
- 2 RECOMMENDED MOUNTING TORQUE ON .312 [7.93] HEX: 20-25 FT-LBS [27-34 Nm]
- 1 MATERIAL: C-300 MARAGING STEEL

UNLESS OTHERWISE SPECIFIED TOLERANCES ARE:		DRAWN		CHECKED		ENGINEER	
DIMENSIONS IN INCHES	DIMENSIONS IN MILLIMETERS [IN BRACKETS]	JJF	5/21/21	JJF	5/21/21	NJL	5/21/21
DECIMALS XX ±.01 XXX ±.005	DECIMALS X ±.03 XX ±.013	TITLE INSTALLATION DRAWING MODEL 108A02, 108A04 HERMETICALLY SEALED PRESSURE SENSOR					
ANGLES ± 2 DEGREES	ANGLES ± 2 DEGREES						
FILLETS AND RADII .003 - .005	FILLETS AND RADII 0.07 - 0.13	CODE IDENT. NO. 52681		DWG. NO. 108-1020-90		SCALE: 3X SHEET 1 OF 1	



3425 WALDEN AVE. DEPEW, NY 14043
(716) 684-0001 E-MAIL: sales@pcb.com