



Model 3501B1220KG

Piezoresistive Accelerometer

Installation and Operating Manual

**For assistance with the operation of this product,
contact the PCB Piezotronics, Inc.**

**Toll-free: 716-684-0001
24-hour SensorLine: 716-684-0001
Fax: 716-684-0987
E-mail: info@pcb.com
Web: www.pcb.com**



Repair and Maintenance

PCB guarantees Total Customer Satisfaction through its “Lifetime Warranty Plus” on all Platinum Stock Products sold by PCB and through its limited warranties on all other PCB Stock, Standard and Special products. Due to the sophisticated nature of our sensors and associated instrumentation, **field servicing and repair is not recommended and, if attempted, will void the factory warranty.**

Beyond routine calibration and battery replacements where applicable, our products require no user maintenance. Clean electrical connectors, housings, and mounting surfaces with solutions and techniques that will not harm the material of construction. Observe caution when using liquids near devices that are not hermetically sealed. Such devices should only be wiped with a dampened cloth—never saturated or submerged.

In the event that equipment becomes damaged or ceases to operate, our Application Engineers are here to support your troubleshooting efforts 24 hours a day, 7 days a week. Call or email with model and serial number as well as a brief description of the problem.

Calibration

Routine calibration of sensors and associated instrumentation is necessary to maintain measurement accuracy. We recommend calibrating on an annual basis, after exposure to any extreme environmental influence, or prior to any critical test.

PCB Piezotronics is an ISO-9001 certified company whose calibration services are accredited by A2LA to ISO/IEC 17025, with full traceability to SI through N.I.S.T. In addition to our standard calibration services, we also offer specialized tests, including: sensitivity at elevated or cryogenic temperatures, phase response, extended high or low frequency response, extended range, leak testing, hydrostatic pressure testing, and others. For more information, contact your local PCB Piezotronics distributor, sales representative, or factory customer service representative.

Returning Equipment

If factory repair is required, our representatives will provide you with a Return Material Authorization (RMA) number, which we use to reference any information you have already provided and expedite the repair process. This number should be clearly marked on the outside of all returned package(s) and on any packing list(s) accompanying the shipment.

Contact Information

PCB Piezotronics, Inc.
3425 Walden Ave.
Depew, NY14043 USA
Toll-free: (800) 828-8840
24-hour SensorLine: (716) 684-0001
General inquiries: info@pcb.com
Repair inquiries: rma@pcb.com

For a complete list of distributors, global offices and sales representatives, visit our website, www.pcb.com.

Safety Considerations

This product is intended for use by qualified personnel who recognize shock hazards and are familiar with the precautions required to avoid injury. While our equipment is designed with user safety in mind, the protection provided by the equipment may be impaired if equipment is used in a manner not specified by this manual.

Discontinue use and contact our 24-Hour Sensorline if:

- Assistance is needed to safely operate equipment
- Damage is visible or suspected
- Equipment fails or malfunctions

For complete equipment ratings, refer to the enclosed specification sheet for your product.

Definition of Terms and Symbols

The following symbols may be used in this manual:



DANGER

Indicates an immediate hazardous situation, which, if not avoided, may result in death or serious injury.

**CAUTION**

Refers to hazards that could damage the instrument.

**NOTE**

Indicates tips, recommendations and important information. The notes simplify processes and contain additional information on particular operating steps.

The following symbols may be found on the equipment described in this manual:



This symbol on the unit indicates that high voltage may be present. Use standard safety precautions to avoid personal contact with this voltage.



This symbol on the unit indicates that the user should refer to the operating instructions located in the manual.



This symbol indicates safety, earth ground.



PCB工业监视和测量设备 - 中国RoHS2公布表

PCB Industrial Monitoring and Measuring Equipment - China RoHS 2 Disclosure Table

部件名称	有害物质					
	铅 (Pb)	汞 (Hg)	镉 (Cd)	六价铬 (Cr(VI))	多溴联苯 (PBB)	多溴二苯醚 (PBDE)
住房	0	0	0	0	0	0
PCB板	X	0	0	0	0	0
电气连接器	0	0	0	0	0	0
压电晶体	X	0	0	0	0	0
环氧	0	0	0	0	0	0
铁氟龙	0	0	0	0	0	0
电子	0	0	0	0	0	0
厚膜基板	0	0	X	0	0	0
电线	0	0	0	0	0	0
电缆	X	0	0	0	0	0
塑料	0	0	0	0	0	0
焊接	X	0	0	0	0	0
铜合金/黄铜	X	0	0	0	0	0
本表格依据 SJ/T 11364 的规定编制。						
0：表示该有害物质在该部件所有均质材料中的含量均在 GB/T 26572 规定的限量要求以下。						
X：表示该有害物质至少在该部件的某一均质材料中的含量超出 GB/T 26572 规定的限量要求。						
铅是欧洲RoHS指令2011/65/ EU附件三和附件四目前由于允许的豁免。						

CHINA RoHS COMPLIANCE

Component Name	Hazardous Substances					
	Lead (Pb)	Mercury (Hg)	Cadmium (Cd)	Chromium VI Compounds (Cr(VI))	Polybrominated Biphenyls (PBB)	Polybrominated Diphenyl Ethers (PBDE)
Housing	O	O	O	O	O	O
PCB Board	X	O	O	O	O	O
Electrical Connectors	O	O	O	O	O	O
Piezoelectric Crystals	X	O	O	O	O	O
Epoxy	O	O	O	O	O	O
Teflon	O	O	O	O	O	O
Electronics	O	O	O	O	O	O
Thick Film Substrate	O	O	X	O	O	O
Wires	O	O	O	O	O	O
Cables	X	O	O	O	O	O
Plastic	O	O	O	O	O	O
Solder	X	O	O	O	O	O
Copper Alloy/Brass	X	O	O	O	O	O

This table is prepared in accordance with the provisions of SJ/T 11364.

O: Indicates that said hazardous substance contained in all of the homogeneous materials for this part is below the limit requirement of GB/T 26572.

X: Indicates that said hazardous substance contained in at least one of the homogeneous materials for this part is above the limit requirement of GB/T 26572.

Lead is present due to allowed exemption in Annex III or Annex IV of the European RoHS Directive 2011/65/EU.

1.0 Introduction

This Operating Guide contains information that will familiarize the user with the basic operation and installation of the 3500/3600 Series Piezoresistive (PR) Shock Accelerometers. However, it is not intended to cover all of the specific measurement challenges that one may encounter while using the device. Therefore, if you have detailed questions or are unsure of how to properly operate the sensor after reading this Operating Guide, please contact a PCB Application Engineer using our 24-Hour SensorLine™ at 716-684-0001.

2.0 Principle of Operation

PR accelerometers are passive devices which require stable external power, typically a regulated dc voltage such as 10V (or more recently 5V or 3.3V), to operate with new electronics. These full-bridge sensors include four, active, silicon strain-sensing elements which change resistance proportionally to an applied acceleration. In response to an acceleration input, the resistance will increase for two of the sensing elements and the resistance will decrease for the other two elements, as shown in the Wheatstone-bridge circuit of Figure 1. The sensitivity of the bridge is proportional to the Excitation Voltage.

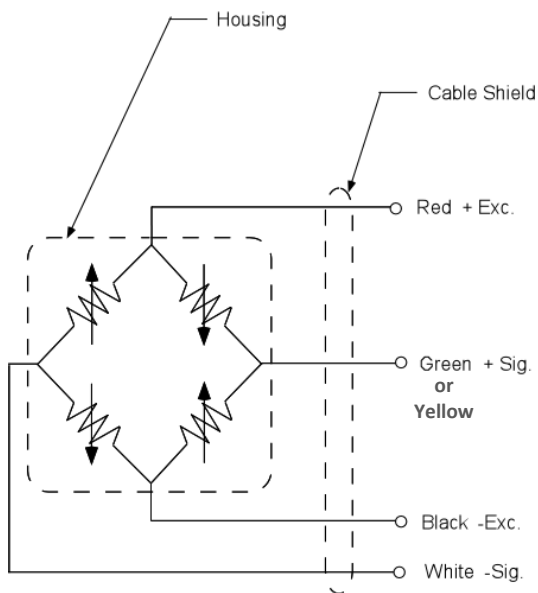

Figure 1 – Wheatstone Bridge Circuit

Terminology related to PR devices includes:

ZMO – Zero Measurand Output, also called bias or offset, is the output when no input acceleration is applied.

TSS – Thermal Sensitivity Shift, the change of sensitivity due to temperature. The sensors are uncompensated, so they

display a slight linear decrease in sensitivity as temperature increases.

TZS – Thermal Zero Shift, the change in ZMO due to temperature. This is less predictable, and from unit to unit may have positive or negative slope, although it will be stable for any one unit.

3.0 Features

The 3500/3600 Series uses micro-electromechanical systems (MEMS) technology, in which all structural and electronic components are manufactured in silicon using electronic microfabrication technologies. MEMS devices are preferred in many high shock impact measurements over piezoelectric elements, since these PR devices are inherently DC coupled, exploit the strength of single crystal silicon (SCS) and display minimal zero shift. However, an additional characteristic of SCS is extremely low internal damping, which results in susceptibility to overshoot and resonant excitation. Although the stiffness of silicon can allow extremely high resonant frequencies in some MEMS shock sensor designs, PCB MEMS sensors take a different approach in which the resonant frequency is intentionally lowered to reduce the response to higher frequency energy present in shock events. The relatively low resonance also creates displacements of the seismic element sufficient to introduce squeeze film damping. Air is used rather than a fluid so thermal effects on damping are negligible.

Manufactured using recent advances in semiconductor processing, the PCB MEMS design consists of a mildly under-damped sensor with sufficient bandwidth to accurately track rigid-body vehicle deceleration. Resonant amplification is reduced by orders of magnitude, and survivability is increased.

Ruggedness is enhanced through the use of mechanical stops. The sensors are manufactured as the sandwich of three wafers, with the active core surrounded by the two outer wafers which provide hermetic protection and restrict the travel of the proof mass.

Because many such applications are coupled with battery powered conditioning and data acquisition, PCB MEMS sensors were designed with relatively high value resistors (approximately 10 times that of other devices) to maximize battery life.

4.0 Common Applications

The 3500/3600 Series PR Shock Accelerometers achieve true DC response for measuring long duration shock. For this reason, they are preferred for applications in which integration from acceleration to velocity or displacement may be

performed. These are violent events. Because of the critical nature of these and similar test applications, PCB MEMS DC Accelerometers have been designed and manufactured with the following common characteristics:

- Rugged, all-welded, titanium housing, or ceramic housing, insures reliability and durability in demanding applications and environments.
- The MEMS sensor includes over-range stops set at approximately twice the full range.
- Gas damping attenuates unwanted high-frequency output.

5.0 Sensor Installation

The 3500/3600 Series DC Accelerometers are available in various forms. Review Outline Drawings and/or Installation Drawings provided with sensors for specific details and requirements related to hardware, mounting, materials, packaging, cabling, etc.

For certain applications not requiring a signal cable, surface mount technology (SMT) style sensors are available upon request. Contact PCB Application Engineers to discuss specific application requirements.

When choosing a mounting method, it's important to take characteristics like location, temperature, environment, and surface condition into consideration. The sensor must be mounted on a clean, flat surface to avoid the potential for misalignment and/or limited contact with the mounting surface which may diminish the sensor's performance. Mounting surface flatness, finish & preparation requirements are indicated on the provided Sensor Installation Drawing. Mounting the sensor will require a clean contact surface to avoid small particles or debris trapped between the mounting surface and sensor that can preload the accelerometer case with unwanted static strain, possibly resulting in zero-shift during a shock measurement.

- Prepare a smooth, flat mounting surface and, if applicable, drill and tap mounting holes according to the Sensor Installation Drawing.
- Wipe clean the mounting surface and, as appropriate, apply a thin film of couplant, such as machinist oil, to enhance transmissibility by filling small voids in the mounting surface and increasing mounting stiffness.
- Hand-tighten the sensor (or mounting hardware, as appropriate), then torque down per the Sensor Installation Drawing. In extreme conditions it's recommended to

check the mounting torque after each measurement. It's also recommended that a thread locking adhesive be applied to any threads, if applicable.

Ceramic LCC (leadless chip carrier) packages available in this series are designed to be installed on circuit boards with conventional surface mounting techniques. An under-fill epoxy is recommended to be used for additional mechanical strength.

6.0 Power

Normally PR devices are powered with regulated excitation, since the sensitivity is proportional to input voltage. PCB MEMS sensors generally exhibit good proportionality (due to minimal self-heating of the comparatively high-resistance elements). Still, it is generally recommended to obtain the calibrated sensitivity using the intended excitation voltage. In integrated applications, in which the data acquisition is powered by the same voltage that supplies the bridge, it is possible to reduce the effect of variations in excitation on overall system sensitivity by using the excitation voltage as the reference for the data acquisition.

7.0 Typical Measurement System

The output from the sensor is typically routed to a bridge conditioner then an oscilloscope or various data acquisition instruments. Consult PCB Application Engineering for additional signal conditioning options. To take advantage of the DC response of the accelerometer, the readout device must be in a DC coupled state. Consult the appropriate manufacturer or product manual for your readout device for details.

8.0 Sensor Verification

Generally the ZMO of a PR transducer is a good measure of the health of the transducer. Input Resistance (from Red to Black) or Output Resistance (from Green or Yellow to White), is less commonly used to check the condition, since resistance changes with temperature. A thorough check of the health (suggested both before and after an expensive test) must include calibration of the sensitivity.

In some laboratories which use piezoresistive transducers, it is customary to check the continuity and gain of the conditioning and data acquisition system using a technique called "Shunt Calibration". By temporarily unbalancing the bridge with a shunt resistor placed in parallel with a leg of the bridge (usually between the "+ Sig" wire and either the "+ Exc" or "- Exc"), dc shifts of the offset are created. Whereas the process does not calibrate the transducer, it is a check of system gain, with accuracy of the resultant dc shift in output dependent on the degree that the resistances of both the leg of the bridge and

the shunt resistor are accurately known. Among other sources of variability, temperature can change the value of the resistors, and therefore the Shunt Calibration output. The user should be aware that because the sensors are full bridge transducers, all legs are active and will have temperature coefficients typical of piezoresistive sensors (approximately +0.1%/degree C).

9.0 Sensor Calibration

For shock accelerometers, the most appropriate, accurate and reliable calibration is with a comparison shock using a back-to-back reference and pneumatic exciter, as described in ISO 16063-22, "Methods for the calibration of vibration and shock transducers — Part 22: Shock calibration by comparison to a reference transducer." PCB offers this calibration as a service.

10.0 Maintenance and Repair

Because of the sophisticated nature of PCB instrumentation, field repair of the equipment is not recommended. Most PCB sensors are of modular construction and are factory repairable. A repair or replacement quotation is available at no charge. Before returning equipment for repair, it is recommended that the user confer with a factory application engineer (or international representative) to first troubleshoot the problem.

11.0 Return Procedure

To expedite the repair process, contact a factory application engineer to obtain a Return Material Authorization (RMA) number prior to sending equipment to the factory. Please have information, such as model number, serial number and description of the problem, available.

Customers outside the U.S. should consult their local PCB distributor for information on returning equipment. For exceptions to this guideline, please contact the International Sales department to request shipping instructions and an RMA.

For further assistance, please call (716) 684-0001 or fax us at (716) 684-0987. You may also receive assistance via e-mail at sales@pcb.com or visit our web site at www.pcb.com

12.0 Customer Service / Warranty

The employees of PCB strive to provide superior, unmatched customer service. Should you at any time find yourself dissatisfied with any PCB product for any reason, consult a factory Application Engineer or local representative/distributor to discuss repair, refund, or exchange procedures.

When unexpected measurement problems arise, call our 24-hour Sensor Line™ at (716) 684-0001 to discuss your

immediate dynamic instrumentation needs with a Factory Representative.

	<u>ENGLISH</u>	<u>SI</u>	
Performance			
Sensitivity(± 50 %)(at 10 VDC excitation)	0.010 mV/g	0.001 mV/(m/s ²)	[1]
Sensitivity	0.001 mV/V/g	0.0001 mV/V/(m/s ²)	
Measurement Range	± 20 kg	± 196,100 m/s ² pk	
Frequency Range(± 1 dB)	0 to 10,000 Hz	0 to 10,000 Hz	
Resonant Frequency	>60 kHz	>60 kHz	
Damping Ratio	5 % Critical	5 % Critical	[5]
Non-Linearity(per 10,000 g (98,100 m/s ²))	≤ 1 %	≤ 1 %	
Transverse Sensitivity	≤ 3 %	≤ 3 %	
Environmental			
Overload Limit(Shock)	± 60,000 g pk	± 588,000 m/s ² pk	[4]
Overload Limit(Mechanical Stops)	≥ 30 kg	≥ 294,200 m/s ² pk	
Temperature Range(Operating)	-65 to 250 °F	-54 to 121 °C	
Temperature Coefficient of Sensitivity	-0.11 %/°F	-0.20 %/°C	[5]
Zero g Offset Temperature Shift	± 10 mV	± 10 mV	[6]
Base Strain Sensitivity	0.10 g/µε	0.98 (m/s ²)/µε	[5]
Magnetic Sensitivity	10 µg/gauss	0.98 (m/s ²)/Tesla	[5]
Electrical			
Excitation Voltage(Maximum)	15.0 VDC	15.0 VDC	
Current Consumption	<3 mA	<3 mA	
Input Resistance(± 2000 Ohm)	6000 Ohm	6000 Ohm	[1]
Output Resistance(± 2000 Ohm)	6000 Ohm	6000 Ohm	[1]
Offset Voltage	-40 to +40 mVDC	-40 to +40 mVDC	[1]
Settling Time	0.01 sec	0.01 sec	[2]
Electrical Isolation(Case)	≥ 10 ⁷ Ohm	≥ 10 ⁷ Ohm	[3]
Physical			
Sensing Element	Piezoresistive MEMS	Piezoresistive MEMS	
Sensing Geometry	Full Active	Full Active	
Housing Material	Titanium	Titanium	
Sealing	Epoxy	Epoxy	
Size (Hex x Height)	3/8 in x .50 in	3/8 in x 12.7 mm	
Weight(without cable)	0.088 oz	2.5 gm	[5]
Electrical Connector	Integral Cable	Integral Cable	
Electrical Connection Position	Side	Side	
Cable Type	096 4-cond silicone jacket	096 4-cond silicone jacket	
Cable Termination	Pigtail Ends	Pigtail Ends	
Cable Length	10 ft	3.05 m	
Mounting	Integral Stud	Integral Stud	
Mounting Thread	1/4-28 Male	1/4-28 Male	

OPTIONAL VERSIONS		
Optional versions have identical specifications and accessories as listed for the standard model except where noted below. More than one option may be used.		
M - Metric Mount		
Mounting Thread	M6 x 0.75 Male	M6 x 0.75 Male

- NOTES:**
- [1] Verified with test data provided on supplied calibration certificate.
 - [2] Settling Time is the maximum time after power-up for the Offset Voltage to be within +/-2% of Measurement Range output of the final offset value. Mounting surface must be at thermal equilibrium.
 - [3] Individually tested to ensure compliance with specified value.
 - [4] Half-sine pulse duration, ≥ 20 µsec.
 - [5] Typical.
 - [6] -65 to +250 °F, ref. 75 °F (-54 to +121 °C, ref. 24 °C)
 - [7] See PCB Declaration of Conformance PS151 for details.

SUPPLIED ACCESSORIES:
 Model ACS-62 Shock Pulse Calibration of single axis piezoresistive shock accelerometer to maximum amplitude of 5k g, 10.0 VDC excitation

Entered: LK	Engineer: JS	Sales: RWM	Approved: JJB	Spec Number:
Date: 11/28/2017	Date: 11/28/2017	Date: 11/28/2017	Date: 11/28/2017	65013



All specifications are at room temperature unless otherwise specified.
 In the interest of constant product improvement, we reserve the right to change specifications without notice.

ICP® is a registered trademark of PCB Group, Inc.

3425 Walden Avenue, Depew, NY 14043

Phone: 716-684-0001
Fax: 716-684-0987
E-Mail: info@pcb.com

PCB Piezotronics Inc. claims proprietary rights in the information disclosed hereon. Neither it nor any reproduction thereof will be disclosed to others without the written consent of PCB Piezotronics Inc.

65015



**ESD SENSITIVE
CLASS 2 HANDLING REQUIRED**

4 MOUNTING HOLE PREPARATION:
 $\varnothing.218[5.41] \nabla .30 [7.6] \text{ MIN}$
 $1/4-28 \text{ UNF-3B } \nabla .20[5.1] \text{ MIN}$

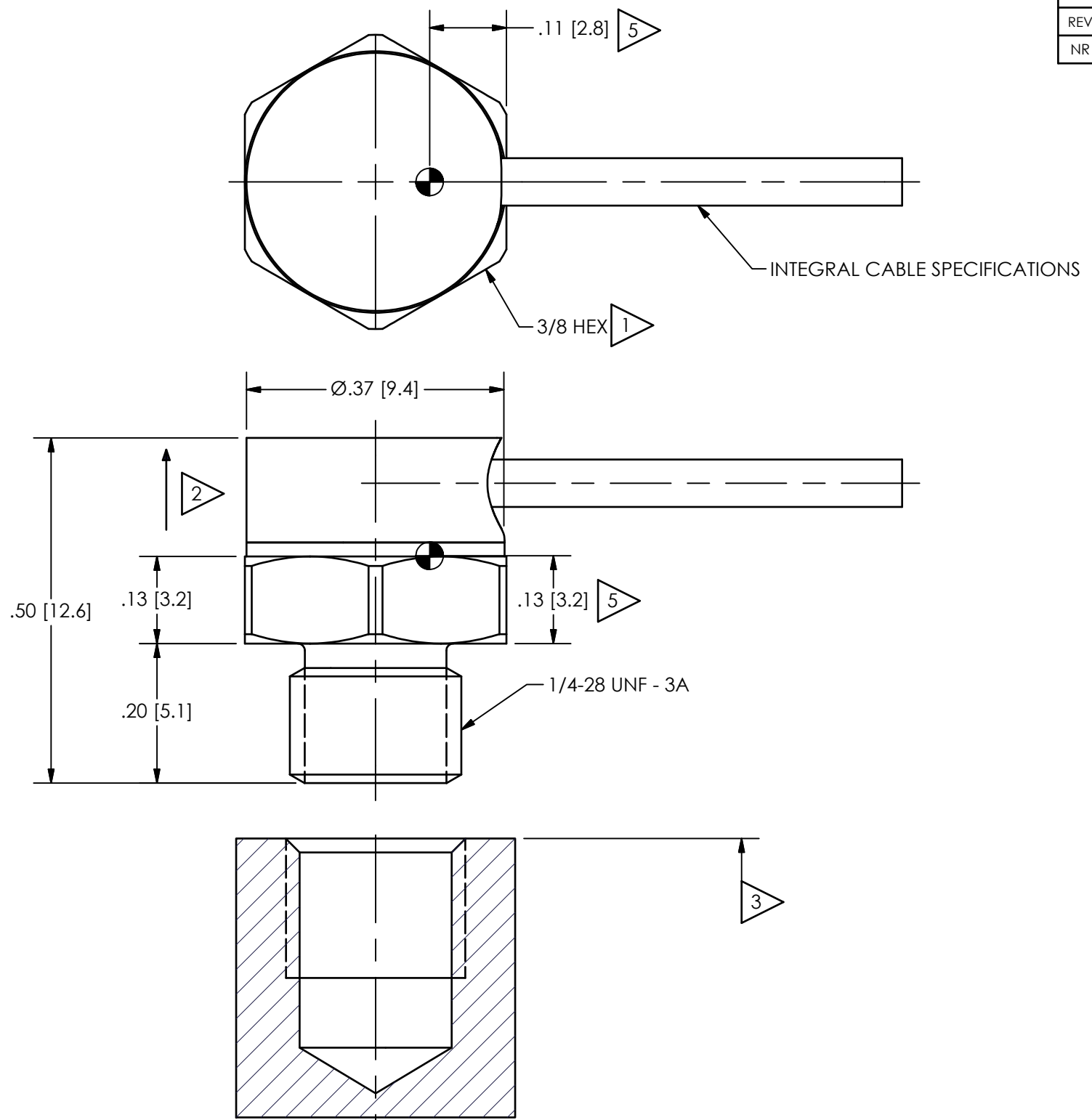

REVISIONS		
REV	DESCRIPTION	ECO
NR	RELEASED TO DRAFTING	45768

ELECTRICAL CONNECTIONS
 GREEN : + SIGNAL
 WHITE : - SIGNAL
 RED: + EXCITATION
 BLACK: - EXCITATION

- 5 CENTER OF SEISMIC MASS
- 4 DRILL PERPENDICULAR TO MOUNTING SURFACE TO WITHIN $\pm 1^\circ$
- 3 RECOMMENDED MOUNTING SURFACE SHOULD BE FLAT TO WITHIN $.0003(.008)$
TIR OVER $\varnothing.650[16.51]$ WITH A SURFACE FINISH OF 32 $[\text{.08}]$ FINISH FOR BEST RESULTS
- 2 DIRECTION OF POSITIVE OUTPUT
- 1 RECOMMENDED MOUNTING TORQUE ON $3/8 \text{ HEX}$, 1-2 FOOT POUND
[1.4-2.7 NEWTON METERS]

UNLESS OTHERWISE SPECIFIED TOLERANCES ARE:		DRAWN		CHECKED		ENGINEER	
DIMENSIONS IN INCHES	DIMENSIONS IN MILLIMETERS [IN BRACKETS]	KRM	9/20/16	JDG	9/20/16	GCD	9/20/16
DECIMALS XX $\pm .01$ XXX $\pm .005$	DECIMALS X ± 0.3 XX ± 0.13	TITLE INSTALLATION DRAWING MODEL 3501B12XXKG SERIES ACCELEROMETER					
ANGLES ± 2 DEGREES	ANGLES ± 2 DEGREES						
FILLETS AND RADII .003 - .005	FILLETS AND RADII 0.07 - 0.13	CODE IDENT. NO. 52681		DWG. NO. 65015		3425 WALDEN AVE. DEPEW, NY 14043 (716) 684-0001 E-MAIL: sales@pcb.com	
		SCALE: 5X		SHEET 1 OF 1			

