



Model 3753A1220G

Triaxial variable capacitance MEMS accelerometer, 20g, single-ended, screw mount, integral 10 ft cable

Installation and Operating Manual

**For assistance with the operation of this product,
contact the PCB Piezotronics, Inc.**

**Toll-free: 716-684-0001
24-hour SensorLine: 716-684-0001
Fax: 716-684-0987
E-mail: info@pcb.com
Web: www.pcb.com**



General OPERATING GUIDE

for use with

High Sensitivity DC ACCELEROMETERS

PCB ASSUMES NO RESPONSIBILITY FOR DAMAGE CAUSED TO THIS PRODUCT AS A RESULT OF PROCEDURES THAT ARE INCONSISTENT WITH THIS OPERATING GUIDE

1.0 Introduction

This operating guide contains information that will familiarize the user with the basic operation and installation of the 3753 Series MEMS DC Accelerometers. However, it is not intended to cover all of the specific measurement challenges that one may encounter while using the device. Therefore, if you have detailed questions or are unsure of how to properly operate the sensor after reading this “Operating Guide”, please contact a PCB Application Engineer using our 24-Hour SensorLine™ at 716-684-0001.

2.0 Common Applications and Features

The 3753 Series MEMS DC Accelerometers achieve true DC response for measuring uniform (or constant) acceleration and low-frequency vibration. For this reason, they are often used to:

- Perform ride quality assessments of elevators, automobiles, trains, and amusement park rides.
- Analyze the low frequency characteristics of buildings, bridges, and large aerospace objects.
- Acquire tilt and orientation data for feedback control and stabilization purposes.

Because of the critical nature of these and similar test applications, all 3753 series MEMS DC Accelerometers have been designed and manufactured with the following common characteristics:

- Built-in electronics provide conveniently standardized sensitivities and low-noise output signals unmatched by similar sensing technologies.
- Internal voltage regulator allows sensor to be powered from virtually any unregulated DC voltage source, such as a bench-top power supply or portable battery source.
- Filtering attenuates unwanted high-frequency vibration, and provides stable performance over the entire operating temperature range.

- Electrical case isolation minimizes ground loops during installations.
- Sensor housing is isolated from mounting surface by the anodized aluminum housing.

3.0 Principle of Operation

The sensor element is connected as a bridge element in the circuit. The electrical characteristics of one portion of the bridge increase in value while the characteristics of the other portion decrease when exposed to acceleration. This approach minimizes common mode errors and improves non-linearity.

A selection of full scale measurement ranges is attained by modifying the stiffness of the suspension system of the proof mass. A high natural frequency is accomplished through the combination of a lightweight proof mass and suspension stiffness.

4.0 Typical Measurement System

The 3753 series DC Accelerometers are available in a triaxial package. The output signal is routed to follow-on signal conditioning via integral cable. Since the High Sensitivity DC Accelerometers contain a built-in voltage regulator, they may be powered from virtually any power source without adversely affecting sensor performance, please refer to sensor specification for voltage range and current requirements. Consult PCB Application Engineering for signal conditioning options if needed. The output from the signal conditioner is typically routed to readout instrumentation such as oscilloscopes or various model data acquisition instruments.

5.0 Sensor Installation

When choosing an installation technique, be certain to carefully examine the different application characteristics that may affect sensor performance. A summary of the recommended mounting methods is provided below.

Screw Mount: Recommended for permanent mount applications or in test situations that require a rugged or secure installation. The necessary information, including surface finish, mounting hole dimensions, and recommended mounting torque for installing the sensor is listed on the enclosed Sensor Installation Drawing. It is recommended that an experienced technician or machinist with good machining capabilities adequately prepare the surface.

Adhesive Mount: Recommended for temporary mounting of the sensor or when the test object surface cannot be properly prepared for screw mounting. Wax works well for temporary mount applications under conditions where the operating temperature will not melt the wax or the acceleration levels will not dislodge the sensor from the test object. If using cyanoacrylate-based adhesives for a quick mounting method or two-part epoxies for a more secure mount, care must be taken as to not damage the sensor during removal.

NOTE: *A chemical debonder should always be used*

With so many adhesives in use (everything from super glues, dental cement, epoxies, etc), there is no universal de-bonding agent available. The de-bonder for the Loctite 454 adhesive that PCB offers is Acetone. If you are using anything other than Loctite 454, you will have to check with the individual manufacturers for their de-bonding recommendations. The de-bonding agent must be allowed to penetrate the surface in order to properly react with the adhesive, so it is advisable to wait a few minutes before removing the sensor.

After the de-bonding agent has softened the adhesive, use a gentle shearing (or twisting) motion to remove the base and/or sensor from the test structure.

6.0 Powering

The 3753 Series contains built-in microelectronics that will operate from many PCB Sensor Signal Conditioners. These signal conditioners provide the necessary voltage and current required for all of the powering options available on the 3753 series. If a signal conditioner is needed, please consult with the factory for the proper conditioner that best fits the application.

The 3753 series may also be powered by other voltage sources such as DC voltage laboratory supplies, automotive or marine batteries, or low-voltage supplies designed for powering PC Board components. Ensure that the source provides power within the excitation voltage range and current listed on the specification sheet for that model. It is important to note that since the accelerometers contain a built-in voltage regulator, precise calibration of the power source is generally not required.

7.0 Operation

After the sensor has been installed and the cable connected for proper operation, there are a couple of measurement points to take note of:

- To take advantage of the DC response of the accelerometer, the readout device must be in a DC coupled state. Consult the appropriate manufacturer or product manual for your readout device for details.
- Because the 3753 series can measure static (constant) accelerations, the DC offset voltage will be affected by the positional alignment relative to the Earth's gravity. If the sensor is mounted parallel with the Earth's surface, the sensor will be experiencing 1 g of acceleration and the offset voltage will increase by the sensitivity of the accelerometer.
- If the sensor is extended, in the case of an integral cable sensor, or a cable length other than 10 ft is used, in the case of sensor with an integral connector, the offset voltage will change. To determine the accelerometer's offset, rotate the unit 90° so that the sensor is on its side with the sensing axis perpendicular to Earth's gravity and record the DC output. This value is the new "zero-g offset voltage."
- Connect the shield wire, which is connected to the sensor housing, to the signal instrumentation ground to maximize electrical noise shielding. Do not leave shield unconnected.

- Each of the sensor outputs (X/Y/Z), will have a bias voltage of 2.5VDC while at 0g orientation per respective axis. The output from the sensor ($\pm 2V$ FSO) will be varying on this bias voltage. Therefore, the maximum sensor FSO is 0.5VDC to 4.5VDC. This represents the $\pm 2V$ from the acceleration full scale range plus the 2.5VDC 0g offset.

8.0 Sensor Verification

If the sensor has been handled in a rough manner or before using a sensor for a critical measurement application, it is a good idea to verify that the sensor's sensitivity is still within specification. An accurate static calibration of the 3753 series can be performed using the Earth's Gravitational Field as a reference. The sensor can simply be "flipped" (rotated 180°) in the Earth's Gravity to obtain the scaling factor (sensitivity) and DC offset. First, place the accelerometer in a +1g orientation so that the base is resting on the table and the model number is facing up. The sensing axis will be parallel with the Earth's gravity with the sensor experiencing +1g acceleration. Record the DC output by using a DVM. Then rotate the sensor 180° so that the sensor is inverted (the top of the sensor is resting on the table) and the sensor is experiencing -1g acceleration. Record the DC output. To calculate the sensitivity of the accelerometer, refer to equation 8.1.

$$\text{Sensitivity} = \frac{(+1g) - (-1g)}{2} \quad \text{Eq 8.1}$$

9.0 Sensor Calibration

Due to ISO 9001, ISO Guide 25, or other contractual requirements, it may become necessary to send the accelerometer back to PCB for recalibration. In this case, a complete back-to-back frequency response test will be performed with NIST traceable equipment. It is recommended that the sensor should be stored in its original packaging when not in use or if needed to be shipped.

10.0 Return Procedure

To expedite the return process, contact a factory Application Engineer to obtain a Return Material Authorization (RMA) number prior to sending equipment to the factory. Please have information, such as model number, serial number and description of the problem, available.

Customers outside the U.S. should consult their local PCB distributor for information on returning equipment. For exceptions to this guideline, please contact the International Sales department to request shipping instructions and an RMA.

For further assistance, please call (716) 684-0001 or fax us at (716) 684-0987. You may also receive assistance via e-mail at info@pcb.com or visit our web site at www.pcb.com.

11.0 Customer Service / Warranty

The employees of PCB strive to provide superior, unmatched customer service. Should you at any time find yourself dissatisfied with any PCB product for any reason, consult a factory Application Engineer or local representative/distributor to discuss refund or exchange procedures.

When unexpected measurement problems arise, call our 24-hour SensorLine™ at (716) 684-0001 to discuss your immediate dynamic instrumentation needs with a PCB Application Engineer.

Model Number
3753A 1220G

TRIAxIAL VC MEMS ACCELEROMETER

Revision: NR
ECN #: 56326

Performance	ENGLISH	SI	
Sensitivity(± 10 %)	100 mV/g	10.2 mV/(m/s ²)	[1]
Measurement Range	± 20 g pk	± 196.2 m/s ² pk	
Frequency Range(± 5 %)	0 to 550 Hz	0 to 550 Hz	
Frequency Range(± 3 dB)	0 to 1,500 Hz	0 to 1,500 Hz	
Resonant Frequency	5.5 kHz	5.5 kHz	[2]
Phase Response(100 Hz)	< 10 °	< 10 °	
Non-Linearity	1 %	1 %	[3][2]
Broadband Resolution(0.5 to 100 Hz)	1,000 µg rms	9,810 µm/sec ² rms	[2]
Transverse Sensitivity	1 %	1 %	[2]
Environmental			
Overload Limit(Shock)	± 5,000 g pk	± 49,050 m/s ² pk	
Temperature Range(Operating)	-40 to +250 °F	-40 to +121 °C	
Temperature Coefficient of Sensitivity	± 1 %	± 1 %	[2][4]
Zero g Offset Temperature Coefficient	± 1 % FSO	± 1 % FSO	[5][2][4]
Base Strain Sensitivity	0.0006 g/µε	0.006 (m/s ²)/µε	[2]
Electrical			
Bias Voltage	2.4 to 2.6 VDC	2.4 to 2.6 VDC	
Excitation Voltage	5 to 32 VDC	5 to 32 VDC	
Current Consumption	≤ 3 mA	≤ 3 mA	
Output Impedance	≤ 450 Ohm	≤ 450 Ohm	
Spectral Noise(1 Hz)	90 µg/√Hz	883 (µm/s ²)/√Hz	[2]
Spectral Noise(10 Hz)	120 µg/√Hz	1,177 (µm/s ²)/√Hz	[2]
Spectral Noise(100 Hz)	80 µg/√Hz	785 (µm/s ²)/√Hz	[2]
Electrical Isolation(Case)	> 10 ⁸ Ohm	> 10 ⁸ Ohm	
Physical			
Housing Material	Anodized Aluminum	Anodized Aluminum	
Sealing	IP67	IP67	
Size (Length x Width x Height)	1.00 in x 0.75 in x 0.35 in	25.4 mm x 19.1 mm x 8.9 mm	
Weight(without cable)	0.42 oz	12 gm	[2]
Electrical Connector	Integral Cable	Integral Cable	
Electrical Connection Position	Side	Side	
Cable Termination	Pigtail	Pigtail	
Cable Type	6-conductor	6-conductor	
Cable Length	10 ft	3 m	
Mounting	Through Holes (2)	Through Holes (2)	

OPTIONAL VERSIONS

Optional versions have identical specifications and accessories as listed for the standard model except where noted below. More than one option may be used.

NOTES:

- [1] Measured at 100 Hz, 10 grms.
- [2] Typical.
- [3] Zero-based, least-squares, straight line method.
- [4] -40 to +250°F, ref. 75 °F (-40 to +121 °C, ref. 24 °C)
- [5] FSO= Full Scale Output over the Measurement Range
- [6] See PCB Declaration of Conformance PS027 for details.

SUPPLIED ACCESSORIES:

Model 081A136 Mounting Screw Assembly 4-40 x 1/2" (2)
 Model ACS-1T NIST traceable triaxial amplitude response, 10 Hz to upper 5% frequency. (1)
 Model M081A136 Mounting Screw Assembly M3 x 0.5 x 14mm (2)

Entered: ND	Engineer: LAB	Sales: JM	Approved: NJF	Spec Number:
Date: 01/28/2026	Date: 01/28/2026	Date: 01/28/2026	Date: 01/28/2026	79926



All specifications are at room temperature unless otherwise specified.
 In the interest of constant product improvement, we reserve the right to change specifications without notice.
 This model, designated with an RH prefix, is RoHS compliant. For further details, and to obtain PCB's RoHS Statement of Conformance, please visit <http://www.pcb.com>

PCB PIEZOTRONICS Phone: 716-684-0001
 AN AMPHENOL COMPANY Fax: 716-684-0987
 E-Mail: info@pcb.com

3425 Walden Avenue, Depew, NY 14043

PCB Piezotronics Inc. claims proprietary rights in the information disclosed hereon. Neither it nor any reproduction thereof will be disclosed to others without the written consent of PCB Piezotronics Inc.

79743

REVISIONS		
REV	DESCRIPTION	DIN
NR	RELEASED TO DRAFTING	56326

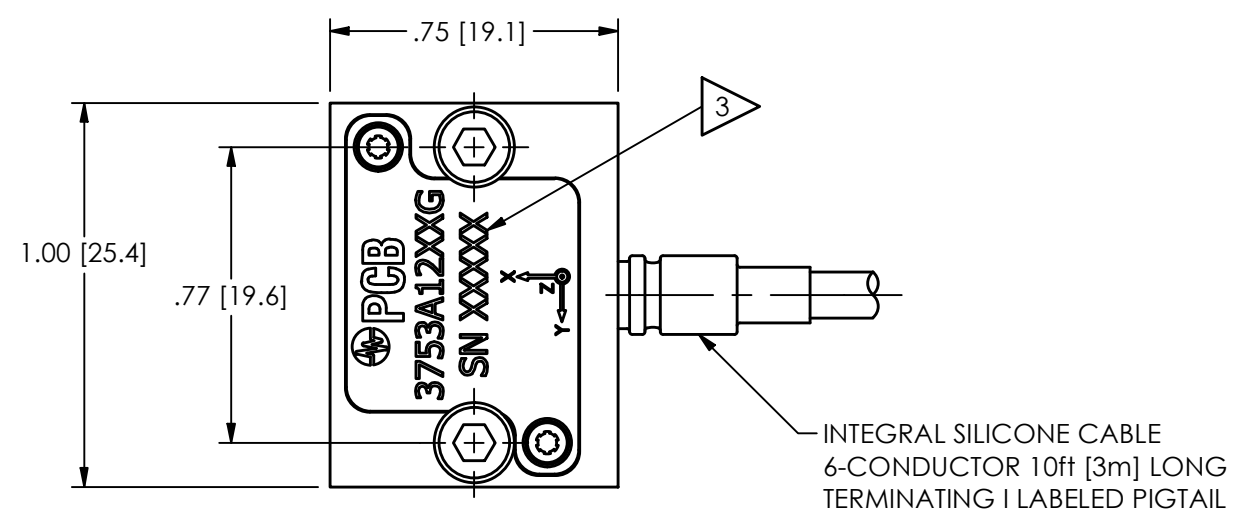

- CABLE TERMINATION:**
- 1.) RED (POWER)
 - 2.) BROWN (X OUTPUT)
 - 3.) GREEN (Y OUTPUT)
 - 4.) WHITE (Z OUTPUT)
 - 5.) BLACK (GROUND)
 - 6.) BLUE (NOT USED, TRIMMED FLUSH)
 - 7.) DRAIN WIRE (SHIELD/CASE GROUND)

OUTPUT SIGNAL:
REFERENCE TO GROUND

POWER:
CONNECT TO DC VOLTAGE POWER SUPPLY. SEE SPECIFICATION SHEET FOR PROPER EXCITATION VOLTAGE

SHIELD:
CASE GROUND

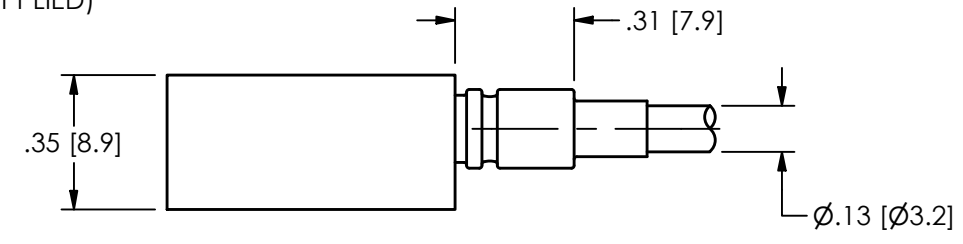
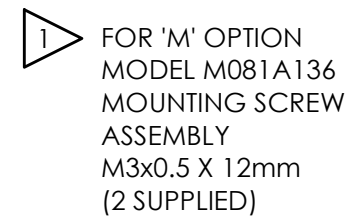
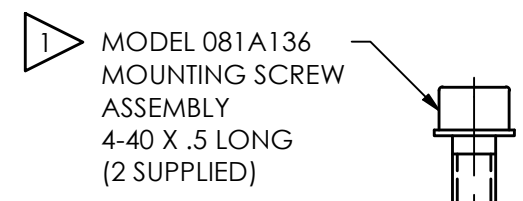

MOUNTING HOLE PREPARATION:
Ø.089[2.26] ∇ .22 [5.6] MIN
4-40 UNC-2B ∇ .15 [3.8] MIN

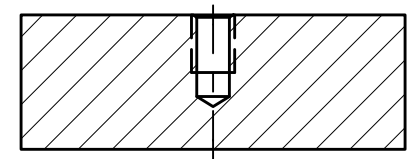

METRIC MOUNTING HOLE PREPARATION:
Ø.098[2.50] ∇ .18 [4.6] MIN
M3 X 0.5-6H ∇ .13 [3.3] MIN

- 4.) SEE SHEET 2 OF 2 FOR CABLE STRAIN RELIEF INFORMATION
- 3 LASER MARK: PCB LOGO, PCB MODEL #, UNIQUE SN. "XX" IN MODEL NUMBER INDICATES FS RANGE (eg 3753A1240G).
- 2 RECOMMENDED MOUNTING SURFACE SHOULD BE FLAT TO WITHIN .003[0.08] TIR OVER Ø1.32[33.3] WITH A SURFACE FINISH OF 32[0.08] FOR BEST RESULTS
- 1 RECOMMENDED MOUNTING TORQUE ON CAP SCREW, 6 in-LB[65 Ncm]

UNLESS OTHERWISE SPECIFIED TOLERANCES ARE:		DRAWN		CHECKED		ENGINEER		PCB PIEZOTRONICS			
DIMENSIONS IN INCHES		AME		JDM		LAB		AN AMPHENOL COMPANY			
DECIMALS	XX ±.03 XXX ±.010	1/30/26	1/30/26	1/30/26	1/30/26	3425 WALDEN AVE. DEPEW, NY 14043 (716) 684-0001 E-MAIL: sales@pcb.com					
DIMENSIONS IN MILLIMETERS [IN BRACKETS]		TITLE INSTALLATION DRAWING MODEL 3753A12XXG SERIES VC TRIAXIAL ACCELEROMETER						CODE IDENT. NO. 52681	SIZE B	DWG. NO. 79743	
CABLE TOLERANCES IN ENGLISH								SCALE: 2X	SHEET 1 OF 2		
CABLE TOLERANCES IN METRIC											
FILLETS AND RADII .003 - .005											
DECIMALS XX ±.03 XXX ±.010		DECIMALS X ± 0.8 XX ± 0.25		ANGLES ± 2 DEGREES		ANGLES ± 2 DEGREES					
CABLE TOLERANCES IN ENGLISH		CABLE TOLERANCES IN METRIC		FILLETS AND RADII .003 - .005		FILLETS AND RADII 0.07 - 0.13					
1" ≤ LENGTH < 1' = +1' / - 0		2.54cm ≤ LENGTH < 30.5cm = +2.54cm / - 0									
1' ≤ LENGTH < 5' = +2' / - 0		30.5cm ≤ LENGTH < 1.5m = +5.1cm / - 0									
5' ≤ LENGTH < 100' = +6' / - 0		1.5m ≤ LENGTH < 30.5m = +15.2cm / - 0									
100' ≤ LENGTH = +1' / - 0		30.5m ≤ LENGTH = +30.5cm / - 0									

79743

PCB Piezotronics Inc. claims proprietary rights in the information disclosed hereon. Neither it nor any reproduction thereof will be disclosed to others without the written consent of PCB Piezotronics Inc.

REVISIONS		
REV	DESCRIPTION	DIN
	-SEE SHEET 1-	

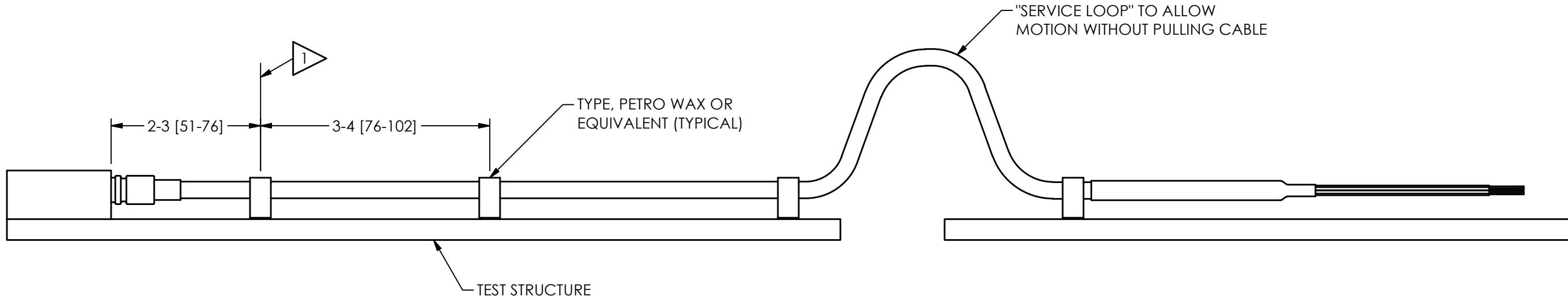

1 FASTEN CABLE TO TEST STRUCTURE TYPICALLY WITHIN 2-3 [51-76] OF SENSOR, THEN FASTEN AGAIN WITHIN 3-4 [76-101] OF PREVIOUS ATTACHMENT, BETWEEN THE TEST STRUCTURE AND A FIXED STRUCTURE, ALLOW A SERVICE LOOP LARGE ENOUGH TO PREVENT PULLING OF THE CABLE WHEN SHAKING, MORE ATTACHMENT POINTS WILL PROVIDE LESS NOISE IN THE RESULTING DATA, LOOSE CABLES OR PARTS ELSEWHERE ON THE TEST STRUCTURE CAN ALSO GENERATE "NOISE" ON THE SIGNAL RECEIVED FROM THE MODEL 3753 SERIES

UNLESS OTHERWISE SPECIFIED TOLERANCES ARE:		DRAWN		CHECKED		ENGINEER		PCB PIEZOTRONICS AN AMPHENOL COMPANY				
DIMENSIONS IN INCHES DECIMALS XX ±.03 XXX ±.010 ANGLES ± 2 DEGREES		DIMENSIONS IN MILLIMETERS [IN BRACKETS] DECIMALS X ± 0.8 XX ± 0.25 ANGLES ± 2 DEGREES		AME	1/30/26	JDM	1/30/26	LAB	1/30/26	3425 WALDEN AVE. DEPEW, NY 14043 (716) 684-0001 E-MAIL: sales@pcb.com		
CABLE TOLERANCES IN ENGLISH 1" ≤ LENGTH < 1' = +1"/ - 0 1' ≤ LENGTH < 5' = +2"/ - 0 5' ≤ LENGTH < 100' = +6"/ - 0 100' ≤ LENGTH = +1' - 0		CABLE TOLERANCES IN METRIC 2.54cm ≤ LENGTH < 30.5cm = +2.54cm/ - 0 30.5cm ≤ LENGTH < 1.5m = +5.1cm/ - 0 1.5m ≤ LENGTH < 30.5m = +15.2cm/ - 0 30.5m ≤ LENGTH = +30.5cm/ - 0		TITLE INSTALLATION DRAWING MODEL 3753A12XXG SERIES VC TRIAXIAL ACCELEROMETER						CODE IDENT. NO. 52681	SIZE B	DWG. NO. 79743
FILLET AND RADII .003 - .005		FILLET AND RADII 0.07 - 0.13								SCALE: 1.25X		SHEET 2 OF 2