



**Model 379A02**  
**Microphone Array Stand**  
**Installation and Operating Manual**

**For assistance with the operation of this product,  
contact PCB Piezotronics, Inc.**

**Toll-free: 800-828-8840**  
**24-hour SensorLine: 716-684-0001**  
**Fax: 716-684-0987**  
**E-mail: [info@pcb.com](mailto:info@pcb.com)**  
**Web: [www.pcb.com](http://www.pcb.com)**





<b>Service, Repair, and Return Policies and Instructions</b>
--

**The information contained in this document supersedes all similar information that may be found elsewhere in this manual.**

**Service** – Due to the sophisticated nature of the sensors and associated instrumentation provided by PCB Piezotronics, user servicing or repair is not recommended and, if attempted, may void the factory warranty. Routine maintenance, such as the cleaning of electrical connectors, housings, and mounting surfaces with solutions and techniques that will not harm the physical material of construction, is acceptable. Caution should be observed to ensure that liquids are not permitted to migrate into devices that are not hermetically sealed. Such devices should only be wiped with a dampened cloth and never submerged or have liquids poured upon them.

**Repair** – In the event that equipment becomes damaged or ceases to operate, arrangements should be made to return the equipment to PCB Piezotronics for repair. User servicing or repair is not recommended and, if attempted, may void the factory warranty.

**Calibration** – Routine calibration of sensors and associated instrumentation is recommended as this helps build confidence in measurement accuracy and acquired data. Equipment calibration cycles are typically established by the users own quality regimen. When in doubt about a calibration cycle, a good “rule of thumb” is to recalibrate on an annual basis. It is

also good practice to recalibrate after exposure to any severe temperature extreme, shock, load, or other environmental influence, or prior to any critical test.

PCB Piezotronics maintains an ISO-9001 certified metrology laboratory and offers calibration services, which are accredited by A2LA to ISO/IEC 17025, with full traceability to SI through N.I.S.T. In addition to the normally supplied calibration, special testing is also available, such as: sensitivity at elevated or cryogenic temperatures, phase response, extended high or low frequency response, extended range, leak testing, hydrostatic pressure testing, and others. For information on standard recalibration services or special testing, contact your local PCB Piezotronics distributor, sales representative, or factory customer service representative.

**Returning Equipment** – *Following these procedures will ensure that your returned materials are handled in the most expedient manner.* Before returning any equipment to PCB Piezotronics, contact your local distributor, sales representative, or factory customer service representative to obtain a Return **Warranty, Service, Repair, and Return Policies and Instructions** Materials Authorization (RMA) Number. This RMA number should be clearly marked on the outside of all package(s) and on the packing

list(s) accompanying the shipment. A detailed account of the nature of the problem(s) being experienced with the equipment should also be included inside the package(s) containing any returned materials.

A Purchase Order, included with the returned materials, will expedite the turn-around of serviced equipment. It is recommended to include authorization on the Purchase Order for PCB to proceed with any repairs, as long as they do not exceed 50% of the replacement cost of the returned item(s). PCB will provide a price quotation or replacement recommendation for any item whose repair costs would exceed 50% of replacement cost, or any item that is not economically feasible to repair. For routine calibration services, the Purchase Order should include authorization to proceed and return at current pricing, which can be obtained from a factory customer service representative.

**Contact Information** – International customers should direct all inquiries to their local distributor or sales office. A

complete list of distributors and offices can be found at [www.pcb.com](http://www.pcb.com). Customers within the United States may contact their local sales representative or a factory customer service representative. A complete list of sales representatives can be found at [www.pcb.com](http://www.pcb.com). Toll-free telephone numbers for a factory customer service representative, in the division responsible for this product, can be found on the title page at the front of this manual. Our ship to address and general contact numbers are:

PCB Piezotronics, Inc.  
3425 Walden Ave.  
Depew, NY14043 USA  
Toll-free: (800) 828-8840  
24-hour SensorLine<sup>SM</sup>: (716) 684-0001  
Website: [www.pcb.com](http://www.pcb.com)  
E-mail: [info@pcb.com](mailto:info@pcb.com)



PCB工业监视和测量设备 - 中国RoHS2公布表  
PCB Industrial Monitoring and Measuring Equipment - China RoHS 2 Disclosure Table

部件名称	有害物质					
	铅 (Pb)	汞 (Hg)	镉 (Cd)	六价铬 (Cr(VI))	多溴联苯 (PBB)	多溴二苯醚 (PBDE)
住房	○	○	○	○	○	○
PCB板	X	○	○	○	○	○
电气连接器	○	○	○	○	○	○
压电晶体	X	○	○	○	○	○
环氧	○	○	○	○	○	○
铁氟龙	○	○	○	○	○	○
电子	○	○	○	○	○	○
厚膜基板	○	○	X	○	○	○
电线	○	○	○	○	○	○
电缆	X	○	○	○	○	○
塑料	○	○	○	○	○	○
焊接	X	○	○	○	○	○
铜合金/黄铜	X	○	○	○	○	○
本表格依据 SJ/T 11364 的规定编制。						
○：表示该有害物质在该部件所有均质材料中的含量均在 GB/T 26572 规定的限量要求以下。						
X：表示该有害物质至少在该部件的某一均质材料中的含量超出 GB/T 26572 规定的限量要求。						
铅是欧洲RoHS指令2011/65/ EU附件三和附件四目前由于允许的豁免。						

CHINA RoHS COMPLIANCE

Component Name	Hazardous Substances					
	Lead (Pb)	Mercury (Hg)	Cadmium (Cd)	Chromium VI Compounds (Cr(VI))	Polybrominated Biphenyls (PBB)	Polybrominated Diphenyl Ethers (PBDE)
Housing	O	O	O	O	O	O
PCB Board	X	O	O	O	O	O
Electrical Connectors	O	O	O	O	O	O
Piezoelectric Crystals	X	O	O	O	O	O
Epoxy	O	O	O	O	O	O
Teflon	O	O	O	O	O	O
Electronics	O	O	O	O	O	O
Thick Film Substrate	O	O	X	O	O	O
Wires	O	O	O	O	O	O
Cables	X	O	O	O	O	O
Plastic	O	O	O	O	O	O
Solder	X	O	O	O	O	O
Copper Alloy/Brass	X	O	O	O	O	O

This table is prepared in accordance with the provisions of SJ/T 11364.

O: Indicates that said hazardous substance contained in all of the homogeneous materials for this part is below the limit requirement of GB/T 26572.

X: Indicates that said hazardous substance contained in at least one of the homogeneous materials for this part is above the limit requirement of GB/T 26572.

Lead is present due to allowed exemption in Annex III or Annex IV of the European RoHS Directive 2011/65/EU.

DOCUMENT NUMBER: 21354

DOCUMENT REVISION: **D**

ECN: 46162

## Assembly Instructions for Grid Array Microphone Stand & Holders

**Parts List:** (see Fig. 1)

- (A) Grid Mount Bar (6 ft / 1.8 m) with threads on one side (*quantity 2*)
- (B) Grid Bar (6 ft / 1.8 m) (*quantity 4*)
- (C) Grid Array Stand Base (cast iron) (*quantity 2*)
- (D) Mounting Clamp – Grid Bar (*quantity 8*)
- (E) Microphone Clip (1/2 in) (*quantity 100*)
- (F) Level, not shown (*quantity 1*)

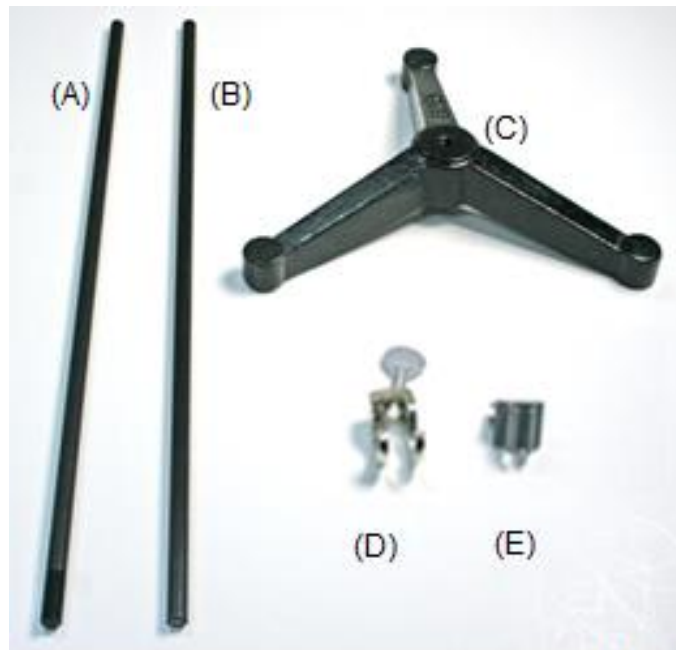

Fig. 1

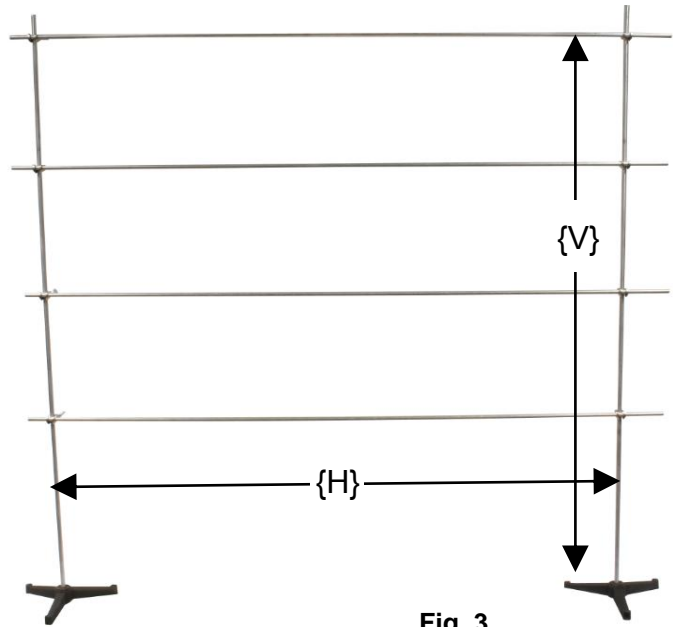

Fig. 2

**Step 1:** (see Fig. 2)

Attach (screw) threaded end of Grid Mount Bar (A) into Grid Array Stand Base (C). Complete this assembly step 2X (see inset photo, Fig. 2).

**Step 2:** (see Fig. 3) Set up horizontal bars for attachment of the array microphones using Grid Bars (B) and make appropriate horizontal lengths {H} using the level (F) included in the kit. The vertical height {V} and spacing of each horizontal grid bar show be adjusted with a scale as required for the application.



**Fig. 3**

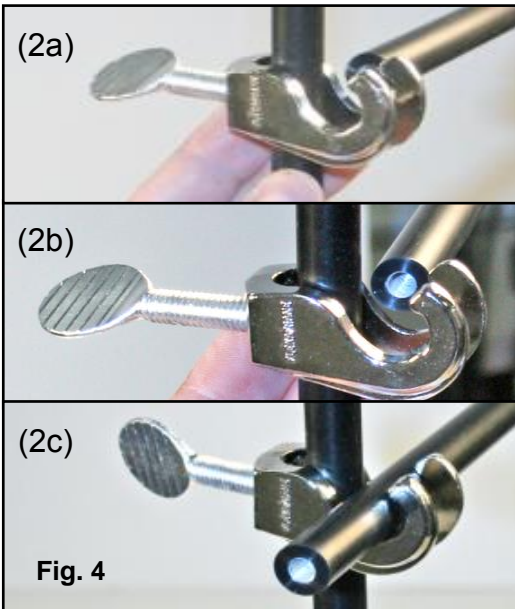
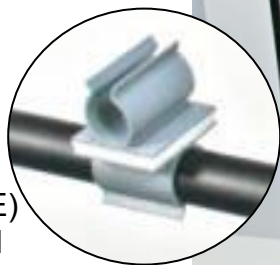

**Fig. 4**

The horizontal Grid Bars are attached to the vertical Grid Mount Bars / Grid Bars with a Mounting Clamp (D) (see inset photos 2a thru 2c) Use two hands for securing the horizontal Grid Bars to the vertical Grid Mount Bars/ Grid Bars with the Mounting Clamp; Tighten Thumb Screw to secure. (see Fig. 4)

**Step 3:** (see Fig. 5) Attach the Microphone Clips (E) as appropriate for the intended sound field measurement application; Set the required spacing using a scale.

Note: The Microphone Clips snap with typical hand force onto the horizontal Grid Bars.



**Fig. 5**

**Step 4:** (see Fig. 6)  
The Grid Array Microphone Stand and Holder Assembly is complete. Attach the appropriate microphones into the Microphone Clips (snap into place with typical hand force).

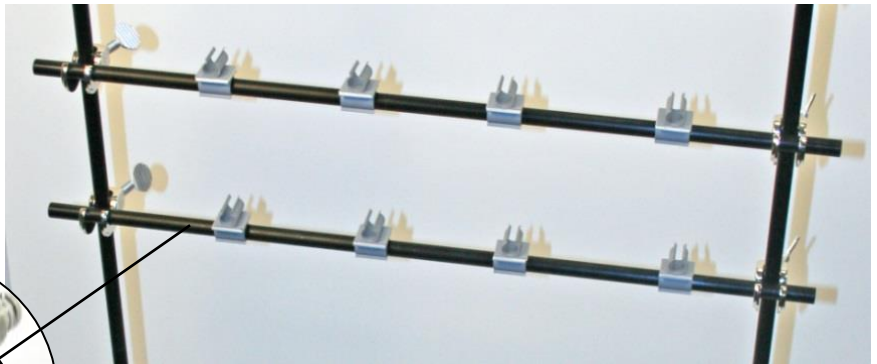

Fig. 6

Note: The 2-D sound measurement array can be assembled with various widths, heights, and microphone spacing to accommodate the application as required. The 1/2" (12mm) diameter rods allow for alternative optional holders and can accommodate other sizes and styles of microphones for the array (See Fig.6)

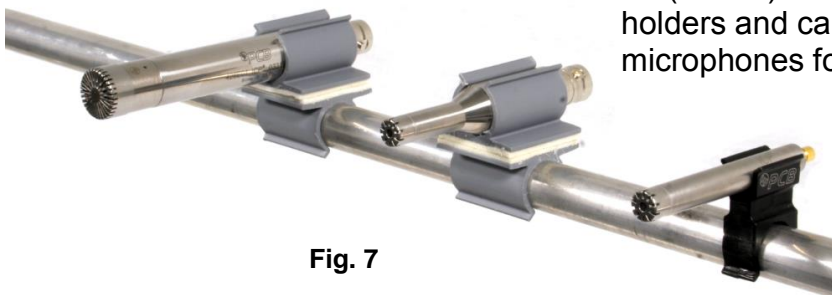

Fig. 7

3425 Walden Avenue, Depew, NY 14043-2495

E-Mail: [info@pcb.com](mailto:info@pcb.com)

Website: [www.pcb.com](http://www.pcb.com)

24-Hour Sensor Line<sup>SM</sup> : 716-684-0001

Fax: 716-684-0987

Toll-Free: 800-828-8840

ISO 9001 CERTIFIED    A2LA ACCREDITED to ISO 17025    AS9100 Certified

© Copyright PCB Group, Inc. 2012. PCB® and ICP® are registered trademarks of PCB Group, Inc.

Manual Number: 52562

Manual Revision: **A**

Document Identification Number: **46007**

Printed in the U.S.A.



## OPERATING GUIDE FOR 130 SERIES MICROPHONES

### *Contents:*

1.0 Introduction.....	1
2.0 Product Description .....	1
3.0 Powering .....	2
4.0 Installation and Operation.....	3
5.0 Calibration.....	4
6.0 Service.....	6
7.0 Warranty.....	6

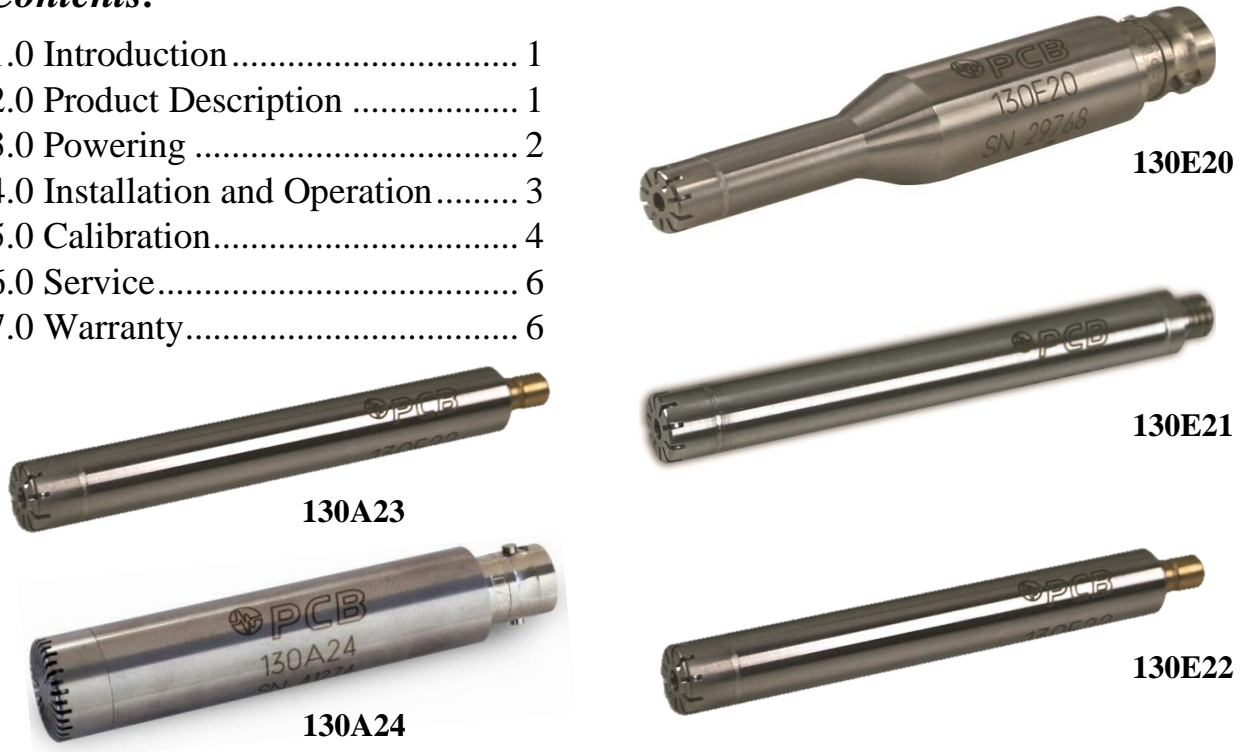

**Figure 1**

### **1.0 Introduction**

Congratulations on the purchase of a quality, ICP<sup>®</sup> Microphone. In order to ensure the highest level of performance for this product, we recommend that you follow the basic installation and operation procedures in this guide. By following these procedures, along with utilizing this Microphone in conjunction with other PCB equipment (Signal Controllers, Power Supplies, Cables, Calibrators, etc.), you will ensure years of trouble-free usage. If, after reading this manual, you have additional questions concerning the Microphone or its application, feel free to call a factory Application Engineer at 716-684-0001, or your nearest PCB Sales Representative.

### **2.0 Product Description**

The PCB 130 series of Array Microphones are prepolarized, condenser microphones coupled with ICP<sup>®</sup> sensor powered preamplifiers and are thus referred to as ICP<sup>®</sup> microphones. This eliminates the need to purchase a separate preamplifier. The 130 series microphones provide an extremely cost-effective method for large channel count sound pressure measurements. Typical applications include sound pressure mapping, acoustic mode analysis, near-field acoustic holography, and vibro-acoustic testing, along with other applications.

The 130E20, 130E21, 130E22, 130A23 and 130A24 Microphones (Figure 1) are all Array Microphones with integral preamplifiers. These Microphones are 7mm in diameter and have a dynamic range of up to 150dB before clipping occurs, depending on the model. The 130A24 is a rugged microphone that is water/dust resistant and 13mm in diameter. The 130E20 and 130A24 include a BNC Jack, 130E21 includes a 10-32 Coaxial Jack, and the 130E22 and 130A23 both include a SMB Coaxial Socket. All 130 series Microphones are Prepolarized. By applying a high temperature polymer material, which contains frozen electrical charges, to the top of the backplate, PCB has eliminated the need for external Polarization. This saves you money and time.

The 130 Series Array Microphones have the following Features:

- Lower per Channel Cost
- Use ICP<sup>®</sup> Sensor Power
- Prepolarized
- Reduce Test Time
- Increase Data Consistency
- Integrate with Signal Conditioners
- Includes TEDS compliant with IEEE 1451.4

With their integrated ICP<sup>®</sup> preamplifier and Prepolarization, these microphones can be powered by simple, inexpensive, constant-current Signal Conditioners. These units are easy to operate, and they interface with many standard signal analysis, data acquisition and recording instruments. They utilize low-impedance cable on which signals can be driven long distances with minimal signal loss.

### 3.0 Powering

All ICP<sup>®</sup> powered microphones require correct constant-current excitation for proper operation. For this reason, use only PCB constant-current signal conditioners or other approved constant-current sources. The signal conditioner consists of a regulated, 18-30 VDC source. The power is regulated by a current-limiting circuit, which provides the constant current excitation required for proper operation of the ICP<sup>®</sup> Microphone. In general, battery powered devices offer versatility for portable low-noise measurements, whereas line-powered units provide the capability for continuous monitoring. A typical system schematic is shown in Figure 2.

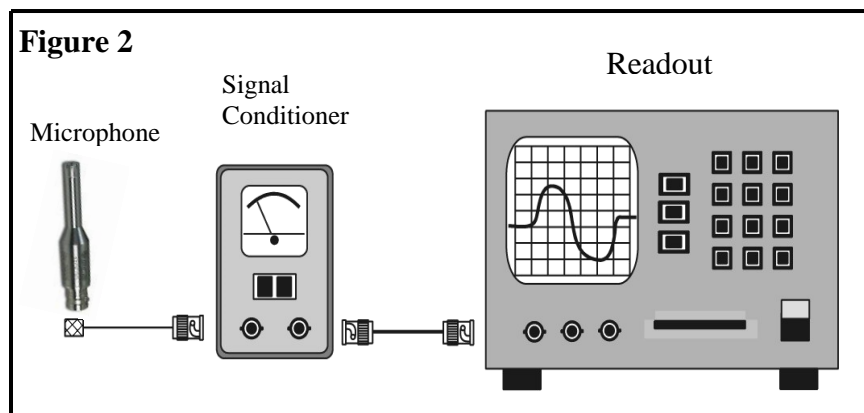

**Note:** Under no circumstances should a voltage be supplied to an ICP<sup>®</sup> microphone without a current-regulating diode or equivalent electrical circuit. This may include ohmmeters, multi-meters and continuity testers. Damage to the built-in electronics resulting from the application of incorrect power, or the use of an unapproved power source, is NOT covered under warranty.

Certain models of signal conditioners have meters or LEDs, which enable users to monitor the bias voltage output signal, check microphone operation, and detect cable faults. Normally, a “yellow” reading indicates an open circuit (example: a cable disconnected); “green” indicates

normal operation and a “red” reading indicates a short circuit (example: a shorted cable). The signal conditioner provides a zero-based, AC-coupled, output signal that is compatible with most standard readout devices.

Many FFT analyzers, data acquisition modules, and data collectors have the proper constant-current excitation built-in for direct use with ICP<sup>®</sup> microphones. Before using this feature, make sure the supply voltage and constant current are within acceptable limits for use with your particular microphone. (Check the enclosed **Specification Sheet**.)

#### 4.0 Installation and Operation

There are many ways to support the microphone to take measurements, from simply placing the microphone in a clip to using a 2D array stand, as determined by your application and budget. After you remove the microphone from its package and have read this operating guide, attach the appropriate cable between the Signal Conditioner and the microphone. You will then need to attach a second cable to connect the Signal Conditioner to your readout device. This is a standard Coaxial cable with BNC connectors on each end. PCB offers these cables in a variety of lengths for any application.

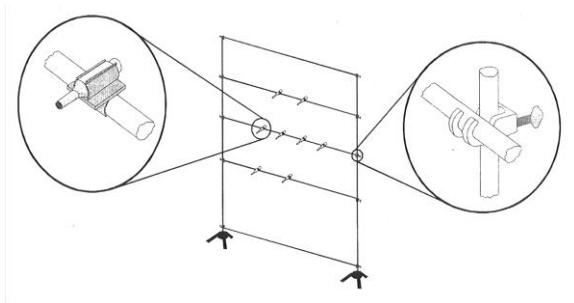

**Figure 3**

When used in conjunction with a large number of signals, for simultaneous measurement, the microphones can be clipped onto a grid network to form a complete array. See Figure 3.

All of the 130 series Array Microphones are the “Free-Field” type. This type of microphone is direction-sensitive and should be pointed directly at the object you are measuring. The “Free-Field” type of microphone is best suited for applications where the sound is coming from one defined direction, without any disturbing objects or hard surfaces that will reflect the sound or cause reverberation. After completing the system setup, power on the signal conditioner and allow 1 to 2 minutes for the system to stabilize. The meter (or LED) on the signal conditioner should be reading “green”. This indicates proper operation and you may begin taking measurements. If a faulty condition is indicated (red or yellow reading), first check all system connections, then check the functionality of the cable and signal conditioner. If the system still does not operate properly, consult a PCB Application Engineer.

The 130A24 microphone design includes a removable grid cap and replaceable protective cover. This unique feature allows the 130A24 to withstand harsh environments while extending the lifespan of the microphones' critical sensitive components. Should the water and dust resistant cover get damaged due to prolonged exposure to harsh conditions, a removable grid cap allows the user to replace this protective cover quickly and easily in a few simple steps. First, unthread the grid cap from the housing. Next, peel off the existing cover from the end of the housing. Sharp edged tools can be used to aid in cover removal, but it is important to keep the tool at an angle that is parallel to the black covers surface area so that no contact with the microphone's delicate diaphragm underneath occurs (Figure 4). To ensure a proper seal, gently wipe the top of the microphone housing to remove any moisture or debris. Apply the replacement water-resistant patch to the end of the housing, keeping it centered. Finally, assemble the grid cap back onto the housing. Optional 079A46 five pack replacement water resistant pads can be ordered from PCB.



**Figure 4**

## **5.0 Calibration**

All PCB microphones come with a certificate of calibration and compliance with ISO 9001 and ANSI/NCSL Z540.3. In order to keep the array microphone cost effective, the 130 series calibrations are not A2LA accredited. For A2LA accredited microphones, please select our 377 and 378 series of acoustic products. PCB microphones are traceable to one or more of the following National Labs (NIST, PTB or DFM), and calibration records are on file. PCB utilizes the "Back-to-Back Reference" form of calibration for the 130 series of array microphones. The microphone is checked against a test and measurement working standard microphone and must meet specifications before it can be shipped. An example of a calibration certificate is shown on the following page (Figure 5).

**~ Calibration Certificate ~**

Model Number: 130E21

Serial Number: 37649

Description: ICP® Microphone

Manufacturer: PCB Method <sup>1</sup>: Back-to-Back Reference

**Calibration Data**

Sensitivity: 48.1 mV/Pa      Reference Freq.: 250 Hz  
-26.4 dB re 1V/Pa      Output Bias: 8.6 VDC

Temperature: 71 °F      22 °C      Relative Humidity: 50 %

**Response Plot**

**Condition of Unit**

As Found: n/a

As Left: New Unit, In Tolerance

**Notes**

1. This method involves comparing the test unit with a reference microphone in a GRAS 51AB calibrator.
2. Calibration is PTB Traceable and calibration records are on file.
3. Calibration is performed in compliance with ISO 9001, ISO 10012-1 and ANSI/NCSL Z540.3.
4. Due to state-of-the-art limitations, 4:1 calibration ratios are not possible on pressure measurement standards, microphones and acoustic calibrators. Calibration ratios for these types of devices are limited to 1:1.
5. See Manufacturer's Specification Sheet for a detailed listing of performance specifications.
6. This certificate shall not be reproduced, except in full, without written approval from PCB Piezotronics, Inc
7. Calibrated per ACS-21.

Technician: Scott Skibniewski      Date: October 29, 2013

**PCB PIEZOTRONICS™**  
VIBRATION DIVISION

Headquarters: 3425 Walden Avenue, Depew, NY 14043  
Calibration performed at: 10869 Highway 903, Halifax, NC 27839

Page 1 of 1      TEL: 888-684-0013      FAX: 716-685-3886      www.pcb.com      CAL58-346591589.795

**Figure 5**

Microphone calibration provides, with a definable degree of accuracy, the necessary link between the physical quantity being measured and the electrical signal generated by the microphone. In addition, other useful information concerning operational limits, physical parameters, electrical characteristics or environmental influences may be determined. Under normal conditions, microphones are very stable. However, the microphone may be temporarily or permanently affected by harsh influences, such as moisture, dirt, being accidentally dropped or other unusual conditions that may cause the microphone accuracy to deviate from the normal specifications. This may manifest itself in a number of ways, ranging from a loss in frequency range, to total failure of the built-in microelectronic circuit due to high mechanical shock.

It is for this reason that PCB recommends that a recalibration cycle be established for each microphone. This schedule is unique and is based upon a variety of factors, such as: extent of use, environmental conditions, accuracy requirements, trend information obtained from previous calibration records, contractual regulations, and risk associated with incorrect readings. PCB recommends 12 to 24 month intervals, depending upon the above factors. In addition, it is also best practice to perform verification both before and after each test. PCB's model CAL 250 Acoustic Calibrator provides a simple method for accomplishing this.

## 6.0 Service

See the supplemental sheet, contained with this manual, for information on our service, repair and return policies, procedures and instructions. When unexpected problems arise, call our 24-Hour SensorLine<sup>SM</sup> (716-684-0001) to discuss your immediate dynamic instrumentation needs with a PCB Application Engineer.

## 7.0 Warranty

All equipment and repair services provided by PCB Piezotronics, Inc. are covered by a limited warranty against defective material and workmanship for a period of one year. Visit [www.PCB.com](http://www.PCB.com) for a complete statement of our warranty.

PCB guarantees **Total Customer Satisfaction**. If, at any time, for any reason, you are not completely satisfied with any PCB product, PCB will repair, replace, or exchange it at no charge. You may also choose within the warranty period to have your purchase price refunded.



3425 Walden Avenue, Depew, NY 14043-2495

E-Mail: [info@pcb.com](mailto:info@pcb.com)

Website: [www.pcb.com](http://www.pcb.com)

24-hour SensorLine<sup>SM</sup>: 716-684-0001

Fax: 716-684-0987

Toll-free: 800-828-8840

ISO 9001 CERTIFIED • A2LA ACCREDITED to ISO 17025 • AS9100 CERTIFIED

In the interest of constant product improvement, specifications are subject to change without notice.

© Copyright PCB Group, Inc. 2013

PCB<sup>®</sup> and ICP<sup>®</sup> are registered trademarks of PCB Group, Inc.  
SensorLine<sup>SM</sup> is a service mark of PCB Group, Inc.

Manual Number: 46455

Manual Revision: G

ECO# 44646

Printed in the U.S.A.