



Model 3991B1120KG

HIGH AMPLITUDE MEMS SHOCK ACCELEROMETER

Installation and Operating Manual

**For assistance with the operation of this product,
contact the PCB Piezotronics, Inc.**

Toll-free: 716-684-0001

24-hour SensorLine: 716-684-0001

Fax: 716-684-0987

E-mail: info@pcb.com

Web: www.pcb.com





Service, Repair, and Return Policies and Instructions
--

The information contained in this document supersedes all similar information that may be found elsewhere in this manual.

Service – Due to the sophisticated nature of the sensors and associated instrumentation provided by PCB Piezotronics, user servicing or repair is not recommended and, if attempted, may void the factory warranty. Routine maintenance, such as the cleaning of electrical connectors, housings, and mounting surfaces with solutions and techniques that will not harm the physical material of construction, is acceptable. Caution should be observed to ensure that liquids are not permitted to migrate into devices that are not hermetically sealed. Such devices should only be wiped with a dampened cloth and never submerged or have liquids poured upon them.

Repair – In the event that equipment becomes damaged or ceases to operate, arrangements should be made to return the equipment to PCB Piezotronics for repair. User servicing or repair is not recommended and, if attempted, may void the factory warranty.

Calibration – Routine calibration of sensors and associated instrumentation is recommended as this helps build confidence in measurement accuracy and acquired data. Equipment calibration cycles are typically established by the users own quality regimen. When in doubt about a calibration cycle, a good “rule of thumb” is to recalibrate on an annual basis. It is

also good practice to recalibrate after exposure to any severe temperature extreme, shock, load, or other environmental influence, or prior to any critical test.

PCB Piezotronics maintains an ISO-9001 certified metrology laboratory and offers calibration services, which are accredited by A2LA to ISO/IEC 17025, with full traceability to SI through N.I.S.T. In addition to the normally supplied calibration, special testing is also available, such as: sensitivity at elevated or cryogenic temperatures, phase response, extended high or low frequency response, extended range, leak testing, hydrostatic pressure testing, and others. For information on standard recalibration services or special testing, contact your local PCB Piezotronics distributor, sales representative, or factory customer service representative.

Returning Equipment – *Following these procedures will ensure that your returned materials are handled in the most expedient manner.* Before returning any equipment to PCB Piezotronics, contact your local distributor, sales representative, or factory customer service representative to obtain a Return **Warranty, Service, Repair, and Return Policies and Instructions** Materials Authorization (RMA) Number. This RMA number should be clearly marked on the outside of all package(s) and on the packing

list(s) accompanying the shipment. A detailed account of the nature of the problem(s) being experienced with the equipment should also be included inside the package(s) containing any returned materials.

A Purchase Order, included with the returned materials, will expedite the turn-around of serviced equipment. It is recommended to include authorization on the Purchase Order for PCB to proceed with any repairs, as long as they do not exceed 50% of the replacement cost of the returned item(s). PCB will provide a price quotation or replacement recommendation for any item whose repair costs would exceed 50% of replacement cost, or any item that is not economically feasible to repair. For routine calibration services, the Purchase Order should include authorization to proceed and return at current pricing, which can be obtained from a factory customer service representative.

Contact Information – International customers should direct all inquiries to their local distributor or sales office. A

complete list of distributors and offices can be found at www.pcb.com. Customers within the United States may contact their local sales representative or a factory customer service representative. A complete list of sales representatives can be found at www.pcb.com. Toll-free telephone numbers for a factory customer service representative, in the division responsible for this product, can be found on the title page at the front of this manual. Our ship to address and general contact numbers are:

PCB Piezotronics, Inc.
3425 Walden Ave.
Depew, NY14043 USA
Toll-free: (800) 828-8840
24-hour SensorLineSM: (716) 684-0001
Website: www.pcb.com
E-mail: info@pcb.com



PCB工业监视和测量设备 - 中国RoHS2公布表
 PCB Industrial Monitoring and Measuring Equipment - China RoHS 2 Disclosure Table

部件名称	有害物质					
	铅 (Pb)	汞 (Hg)	镉 (Cd)	六价铬 (Cr(VI))	多溴联苯 (PBB)	多溴二苯醚 (PBDE)
住房	○	○	○	○	○	○
PCB板	X	○	○	○	○	○
电气连接器	○	○	○	○	○	○
压电晶体	X	○	○	○	○	○
环氧	○	○	○	○	○	○
铁氟龙	○	○	○	○	○	○
电子	○	○	○	○	○	○
厚膜基板	○	○	X	○	○	○
电线	○	○	○	○	○	○
电缆	X	○	○	○	○	○
塑料	○	○	○	○	○	○
焊接	X	○	○	○	○	○
铜合金/黄铜	X	○	○	○	○	○
本表格依据 SJ/T 11364 的规定编制。						
○：表示该有害物质在该部件所有均质材料中的含量均在 GB/T 26572 规定的限量要求以下。						
X：表示该有害物质至少在该部件的某一均质材料中的含量超出 GB/T 26572 规定的限量要求。						
铅是欧洲RoHS指令2011/65/ EU附件三和附件四目前由于允许的豁免。						

CHINA RoHS COMPLIANCE

Component Name	Hazardous Substances					
	Lead (Pb)	Mercury (Hg)	Cadmium (Cd)	Chromium VI Compounds (Cr(VI))	Polybrominated Biphenyls (PBB)	Polybrominated Diphenyl Ethers (PBDE)
Housing	O	O	O	O	O	O
PCB Board	X	O	O	O	O	O
Electrical Connectors	O	O	O	O	O	O
Piezoelectric Crystals	X	O	O	O	O	O
Epoxy	O	O	O	O	O	O
Teflon	O	O	O	O	O	O
Electronics	O	O	O	O	O	O
Thick Film Substrate	O	O	X	O	O	O
Wires	O	O	O	O	O	O
Cables	X	O	O	O	O	O
Plastic	O	O	O	O	O	O
Solder	X	O	O	O	O	O
Copper Alloy/Brass	X	O	O	O	O	O

This table is prepared in accordance with the provisions of SJ/T 11364.

O: Indicates that said hazardous substance contained in all of the homogeneous materials for this part is below the limit requirement of GB/T 26572.

X: Indicates that said hazardous substance contained in at least one of the homogeneous materials for this part is above the limit requirement of GB/T 26572.

Lead is present due to allowed exemption in Annex III or Annex IV of the European RoHS Directive 2011/65/EU.

DOCUMENT NUMBER: 21354

DOCUMENT REVISION: **D**

ECN: 46162

1.0 Introduction

This Operating Guide contains information that will familiarize the user with the basic operation and installation of the 3991 Series Piezoresistive (PR) Shock Accelerometers. However, it is not intended to cover all of the specific measurement challenges that one may encounter while using the device. Therefore, if you have detailed questions or are unsure of how to properly operate the sensor after reading this Operating Guide, please contact a PCB Application Engineer using our 24-Hour SensorLine™ at 716-684-0001.

2.0 Principle of Operation

PR accelerometers are passive devices which require stable external power, typically a regulated dc voltage such as 10V (or more recently 5V or 3.3V), to operate with new electronics. These full-bridge sensors include four, active, silicon strain-sensing elements which change resistance proportionally to the applied acceleration. In response to an acceleration input, the resistance will increase for two of the sensing elements and the resistance will decrease for the other two elements, as shown in the Wheatstone-bridge circuit of Figure 1. The sensitivity of the bridge is proportional to the Excitation Voltage.

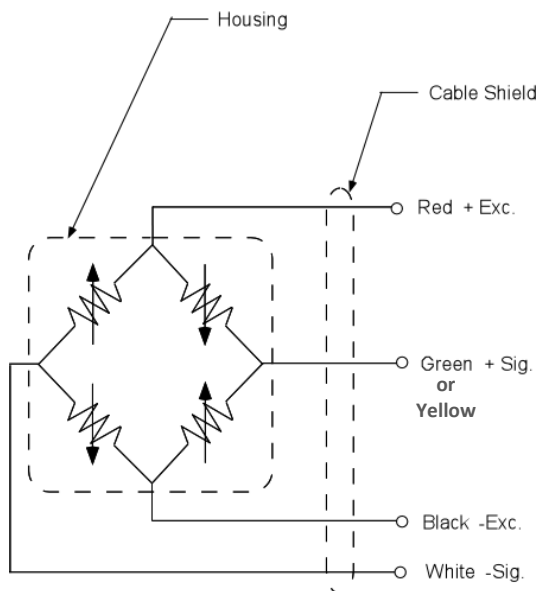

Figure 1 – Wheatstone Bridge Circuit

Terminology related to PR devices includes:

ZMO – Zero Measurand Output, also called bias or offset, is the output when no input acceleration is applied.

TSS – Thermal Sensitivity Shift, the change of sensitivity due to temperature. The sensors are uncompensated, so they

display a slight linear decrease in sensitivity as temperature increases.

TZS – Thermal Zero Shift, the change in ZMO due to temperature. This is less predictable, and from unit to unit may have positive or negative slope, although it will be stable for any one unit.

3.0 Features

The 3991 Series uses micro-electromechanical systems (MEMS) technology, in which all structural and electronic components are manufactured in silicon using electronic micro-fabrication technologies. MEMS devices are preferred in many high shock impact measurements over piezoelectric elements, since these PR devices are inherently DC coupled, exploit the strength of single crystal silicon (SCS) and display minimal zero shift. However, an additional characteristic of SCS is extremely low internal damping, which results in susceptibility to overshoot and resonant excitation. Although the stiffness of silicon can allow extremely high resonant frequencies in some MEMS shock sensor designs, PCB MEMS sensors take a different approach in which the resonant frequency is intentionally lowered to reduce the response to higher frequency energy present in shock events. The relatively low resonance also creates displacements of the seismic element sufficient to introduce squeeze film damping. Air is used rather than a fluid so thermal effects on damping are negligible.

Manufactured using recent advances in semiconductor processing, the PCB MEMS design consists of a mildly under-damped sensor with sufficient bandwidth to accurately track rigid-body vehicle deceleration. Resonant amplification is reduced by orders of magnitude, and survivability is increased.

Ruggedness is enhanced through the use of mechanical stops. The sensors are manufactured as the sandwich of three wafers, with the active core surrounded by the two outer wafers which provide hermetic protection and restrict the travel of the proof mass.

Because many such applications are coupled with battery powered conditioning and data acquisition, PCB MEMS sensors were designed with relatively high value resistors (approximately 10 times that of other devices) to maximize battery life.

4.0 Common Applications

The 3991 Series PR Shock Accelerometers achieve true DC response for measuring long duration shock. For this reason,

they are preferred for applications in which integration from acceleration to velocity or displacement may be performed:

- Rigid-body motion penetration studies
- Drop testing
- Projectile launch

These are violent events. Because of the critical nature of these and similar test applications, all 3991 series MEMS DC Accelerometers have been designed and manufactured with the following common characteristics:

- Rugged, all-welded, titanium housing, or ceramic housing, insures reliability and durability in demanding applications and environments.
- The MEMS sensor includes over-range stops set at approximately twice the full range.
- Gas damping attenuates unwanted high-frequency output.

5.0 Sensor Installation

The 3991 Series DC Accelerometers are available in various forms. The titanium packages of the 3991 “through-hole mount” family include two 4-40 mounting screws. The two mounting holes are spaced 0.375” apart, as is common to industry fixturing. For installations which require soldering at cable connections, use isopropyl alcohol to remove the black anti-triboelectric coating from exposed portions of the conductors and/or braided shield prior to soldering. (If the coating is not removed and allowed to touch the conductors, it will reduce the insulation between leads.)

For certain applications not requiring a signal cable, surface mount technology (SMT) style sensors are available upon request. Contact PCB Application Engineers to discuss specific application requirements.

When choosing a mounting method, it’s important to take characteristics like location, temperature, environment, and surface condition into consideration. The sensor must be mounted on a clean, flat surface to avoid the potential for misalignment and/or limited contact with the mounting surface which may diminish the sensor’s performance. Mounting surface flatness, finish & preparation requirements are indicated on the provided Sensor Installation Drawing. Mounting the sensor will require a clean contact surface to avoid small particles or debris trapped between the mounting surface and sensor that can preload the accelerometer case

with unwanted static strain, possibly resulting in zero-shift during a shock measurement.

- Prepare a smooth, flat mounting surface and, if applicable, drill and tap mounting holes according to the Sensor Installation Drawing.
- Wipe clean the mounting surface and, as appropriate, apply a thin film of couplant, such as machinist oil, to enhance transmissibility by filling small voids in the mounting surface and increasing mounting stiffness.
- Hand-tighten the sensor (or mounting hardware, as appropriate), then torque down per the Sensor Installation Drawing. In extreme conditions it’s recommended to check the mounting torque after each measurement. It’s also recommended that a thread locking adhesive be applied to any threads, if applicable.
- For permanent installations in extreme environments it may be necessary to use supplemental epoxy under the mounting surface.

Ceramic LCC (leadless chip carrier) packages available in this series are designed to be installed on circuit boards with conventional surface mounting techniques. An under-fill epoxy is recommended to be used for additional mechanical strength.

6.0 Power

Normally PR devices are powered with regulated excitation, since the sensitivity is proportional to input voltage. PCB MEMS sensors generally exhibit good proportionality (due to minimal self-heating of the comparatively high-resistance elements). Still, it is generally recommended to obtain the calibrated sensitivity using the intended excitation voltage. In integrated applications, in which the data acquisition is powered by the same voltage that supplies the bridge, it is possible to reduce the effect of variations in excitation on overall system sensitivity by using the excitation voltage as the reference for the data acquisition.

7.0 Typical Measurement System

The output from the sensor is typically routed to a bridge conditioner then an oscilloscope or various data acquisition instruments. Consult PCB Application Engineering for additional signal conditioning options. To take advantage of the DC response of the accelerometer, the readout device must be in a DC coupled state. Consult the appropriate manufacturer or product manual for your readout device for details.

8.0 Sensor Verification

Generally the ZMO of a PR transducer is a good measure of the health of the transducer. Input Resistance (from Red to Black) or Output Resistance (from Green or Yellow to White), is less commonly used to check the condition, since resistance changes with temperature. A thorough check of the health (suggested both before and after an expensive test) must include calibration of the sensitivity.

In some laboratories which use piezoresistive transducers, it is customary to check the continuity and gain of the conditioning and data acquisition system using a technique called "Shunt Calibration". By temporarily unbalancing the bridge with a shunt resistor placed in parallel with a leg of the bridge (usually between the "+ Sig" wire and either the "+ Exc" or "- Exc"), dc shifts of the offset are created. Whereas the process does not calibrate the transducer, it is a check of system gain, with accuracy of the resultant dc shift in output dependent on the degree that the resistances of both the leg of the bridge and the shunt resistor are accurately known. Among other sources of variability, temperature can change the value of the resistors, and therefore the Shunt Calibration output. The user should be aware that because the sensors are full bridge transducers, all legs are active and will have temperature coefficients typical of piezoresistive sensors (approximately +0.1%/degree C).

9.0 Sensor Calibration

For shock accelerometers, the most appropriate, accurate and reliable calibration is with a comparison shock using a back-to-back reference and pneumatic exciter, as described in ISO 16063-22, "Methods for the calibration of vibration and shock transducers — Part 22: Shock calibration by comparison to a reference transducer." PCB offers this calibration as a service.

10.0 Maintenance and Repair

Because of the sophisticated nature of PCB instrumentation, field repair of the equipment is not recommended. Most PCB sensors are of modular construction and are factory repairable. A repair or replacement quotation is available at no charge. Before returning equipment for repair, it is recommended that the user confer with a factory application engineer (or international representative) to first troubleshoot the problem.

11.0 Return Procedure

To expedite the repair process, contact a factory application engineer to obtain a Return Material Authorization (RMA) number prior to sending equipment to the factory. Please have

information, such as model number, serial number and description of the problem, available.

Customers outside the U.S. should consult their local PCB distributor for information on returning equipment. For exceptions to this guideline, please contact the International Sales department to request shipping instructions and an RMA.

For further assistance, please call (716) 684-0001 or fax us at (716) 684-0987. You may also receive assistance via e-mail at sales@pcb.com or visit our web site at www.pcb.com

12.0 Customer Service / Warranty

The employees of PCB strive to provide superior, unmatched customer service. Should you at any time find yourself dissatisfied with any PCB product for any reason, consult a factory Application Engineer or local representative/distributor to discuss repair, refund, or exchange procedures.

When unexpected measurement problems arise, call our 24-hour Sensor Line™ at (716) 684-0001 to discuss your immediate dynamic instrumentation needs with a Factory Representative.

Model Number 3991B1120KG	HIGH AMPLITUDE MEMS SHOCK ACCELEROMETER	Revision: D ECN #: 48068
------------------------------------	--	-----------------------------

	ENGLISH	SI	
Performance			
Sensitivity(± 50 %)(at 10 VDC excitation)	0.010 mV/g	0.001 mV/(m/s ²)	[2]
Sensitivity	0.001 mV/V/g	0.0001 mV/V/(m/s ²)	[7]
Measurement Range	± 0 to 20,000 g	± 0 to 196,100 m/s ² pk	
Frequency Range(± 1 dB)	0 to 10,000 Hz	0 to 10,000 Hz	
Resonant Frequency	>60 kHz	>60 kHz	
Damping Ratio	5 % Critical	5 % Critical	[1]
Non-Linearity(per 10,000 g (98,100 m/s ²))	≤ 1 %	≤ 1 %	
Transverse Sensitivity	≤ 3 %	≤ 3 %	
Environmental			
Overload Limit(Shock)	± 60,000 g pk	± 588,400 m/s ² pk	[5]
Overload Limit(Mechanical Stops)	≥ 30 kg	≥ 294,200 m/s ² pk	
Temperature Range(Operating)	-65 to 250 °F	-54 to 121 °C	
Temperature Coefficient of Sensitivity	-0.11 %/°F	-0.20 %/°C	[1]
Zero g Offset Temperature Shift	± 10 mV	± 10 mV	[6]
Base Strain Sensitivity	0.10 g/µε	0.98 (m/s ²)/µε	[1]
Electrical			
Excitation Voltage(Maximum)	15.0 VDC	15.0 VDC	
Current Consumption	<3 mA	<3 mA	
Input Resistance(± 2000 Ohm)	6000 Ohm	6000 Ohm	[1][2]
Output Resistance(± 2000 Ohm)	6000 Ohm	6000 Ohm	[1][2]
Offset Voltage	± 40 mVDC	± 40 mVDC	[2]
Settling Time	0.01 sec	0.01 sec	[3]
Electrical Isolation(Case)	≥ 10 ⁷ Ohm	≥ 10 ⁷ Ohm	[4]
Physical			
Sensing Element	Piezoresistive MEMS	Piezoresistive MEMS	
Sensing Geometry	Full Active	Full Active	
Housing Material	Titanium	Titanium	
Sealing	Epoxy	Epoxy	
Size (Height x Length x Width)	0.12 in x 0.56 in x 0.28 in	3.05 mm x 14.22 mm x 7.11 mm	
Weight(without cable)	0.045 oz	1.28 gm	[1]
Electrical Connector	Integral Cable	Integral Cable	
Electrical Connection Position	Side	Side	
Cable Type	096 4-cond silicone jacket	096 4-cond silicone jacket	
Cable Termination	Pigtail Ends	Pigtail Ends	
Cable Length	10 ft	3.05 m	
Mounting	Through Holes (2)	Through Holes (2)	

OPTIONAL VERSIONS

Optional versions have identical specifications and accessories as listed for the standard model except where noted below. More than one option may be used.

NOTES:

[1] Typical.
 [2] Verified with test data provided on supplied calibration certificate.
 [3] Settling Time is the maximum time after power-up for the Offset Voltage to be within +/-2% of Measurement Range output of the final offset value. Mounting surface must be at thermal equilibrium.
 [4] Individually tested to ensure compliance with specified value.
 [5] Half-sine pulse duration, ≥ 20 µsec.
 [6] -65 to +250 °F, ref. 75 °F (-54 to +121 °C, ref. 24 °C)
 [7] Sensitivity is proportional to excitation voltage, and at other excitation values, sensitivity can be predicted from the 10VDC calibrated value with a small (<~.5%) increase in uncertainty.
 [8] See PCB Declaration of Conformance PS165 for details.

SUPPLIED ACCESSORIES:

Model 081A110 Mounting Screw (4-40 x 1/4" SHCS) (2)
 Model ACS-62 Shock Pulse Calibration of single axis piezoresistive shock accelerometer to maximum amplitude of 5k g, 10.0 VDC excitation

Entered: LK	Engineer: GD	Sales: RWM	Approved: BAM	Spec Number:
Date: 4/10/2018	Date: 4/10/2018	Date: 4/10/2018	Date: 4/10/2018	65881



All specifications are at room temperature unless otherwise specified.
 In the interest of constant product improvement, we reserve the right to change specifications without notice.
 ICP® is a registered trademark of PCB Group, Inc.



Phone: 716-684-0001
Fax: 716-684-0987
E-Mail: info@pcb.com

PCB Piezotronics Inc. claims proprietary rights in the information disclosed hereon. Neither it nor any reproduction thereof will be disclosed to others without the written consent of PCB Piezotronics Inc.

65879



ESD SENSITIVE
CLASS 2 HANDLING REQUIRED

REVISIONS		
REV	DESCRIPTION	DIN
A	REMOVED ITAR CONTROL STAMP	48068

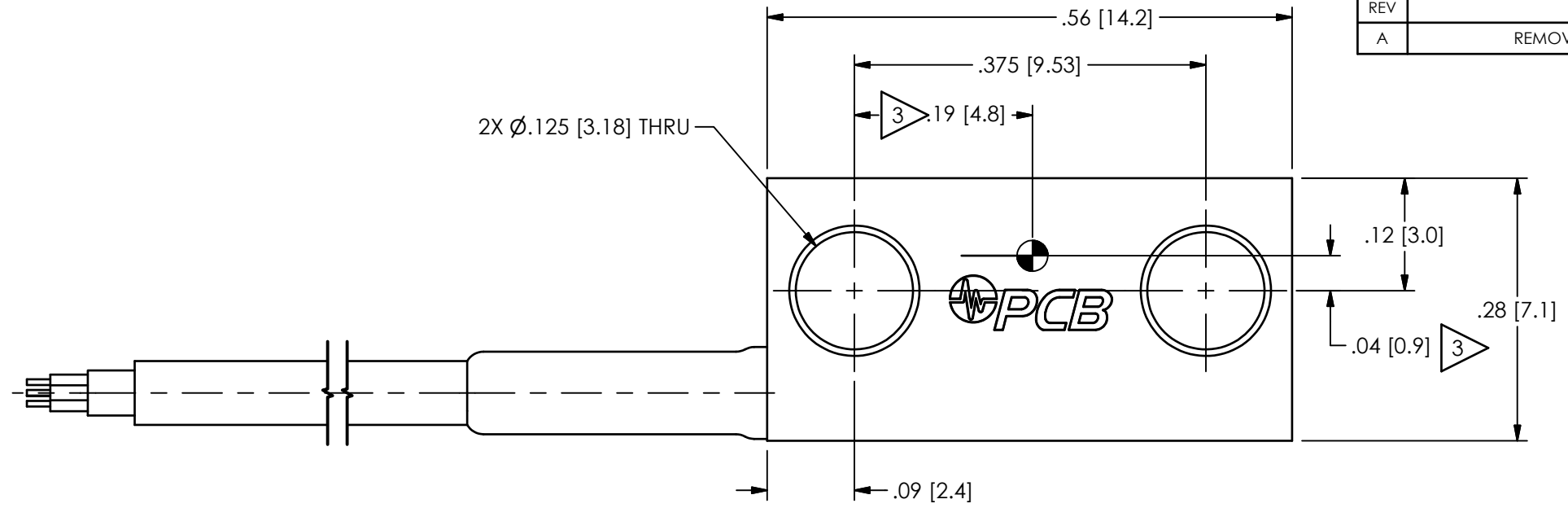

ELECTRICAL CONNECTIONS
 GREEN + SIGNAL
 WHITE - SIGNAL
 RED + EXCITATION
 BLACK - EXCITATION

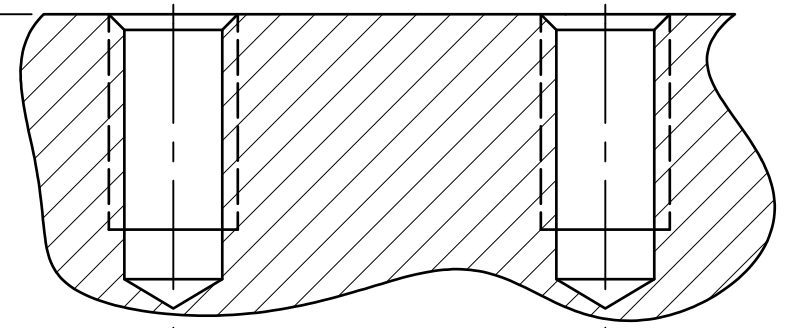
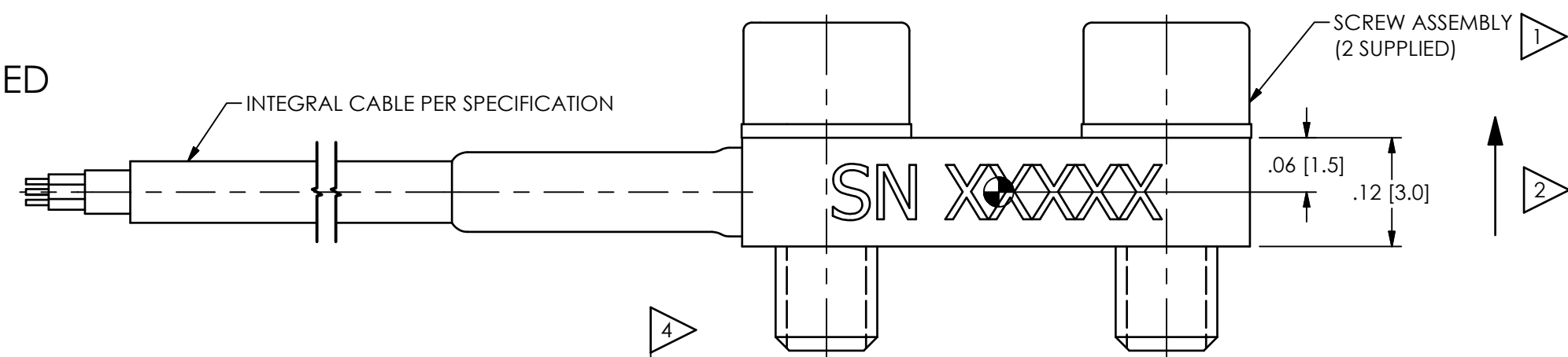

MOUNTING HOLE PREPARATION:
 $\varnothing.089$ [2.26] $\nabla.230$ [5.84]
 4-40 UNC-2B $\nabla.187$ [4.75]

- 4 RECOMMENDED MOUNTING SURFACE SHOULD BE FLAT TO WITHIN .0003 [.008] TIR OVER $\varnothing.650$ [16.51] WITH A 32 [0.08] FINISH FOR BEST RESULTS
- 3 CENTER OF SEISMIC MASS
- 2 DIRECTION OF POSITIVE OUTPUT
- 1 RECOMMENDED MOUNTING TORQUE ON CAP SCREW, 6-8 IN LBS [68-90 N-CM]

UNLESS OTHERWISE SPECIFIED TOLERANCES ARE:		DRAWN		CHECKED		ENGINEER	
DIMENSIONS IN INCHES	DIMENSIONS IN MILLIMETERS [IN BRACKETS]	KRM	4/3/18	KRM	4/3/18	GCD	4/3/18
DECIMALS XX ±.01 XXX ±.005	DECIMALS X ±.03 XX ±.013	TITLE INSTALLATION DRAWING MODEL 3991B11XXKG SERIES ACCELEROMETER					
ANGLES ± 2 DEGREES	ANGLES ± 2 DEGREES						
FILLETS AND RADII .003 - .005	FILLETS AND RADII 0.07 - 0.13	CODE IDENT. NO. 52681		DWG. NO. 65879		SCALE: 4X SHEET 1 OF 2	

PCB PIEZOTRONICS™
 3425 WALDEN AVE. DEPEW, NY 14043
 (716) 684-0001 E-MAIL: sales@pcb.com

65879

PCB Piezotronics Inc. claims proprietary rights in the information disclosed hereon. Neither it nor any reproduction thereof will be disclosed to others without the written consent of PCB Piezotronics Inc.

REVISIONS		
REV	DESCRIPTION	DIN
	-SEE SHEET 1-	

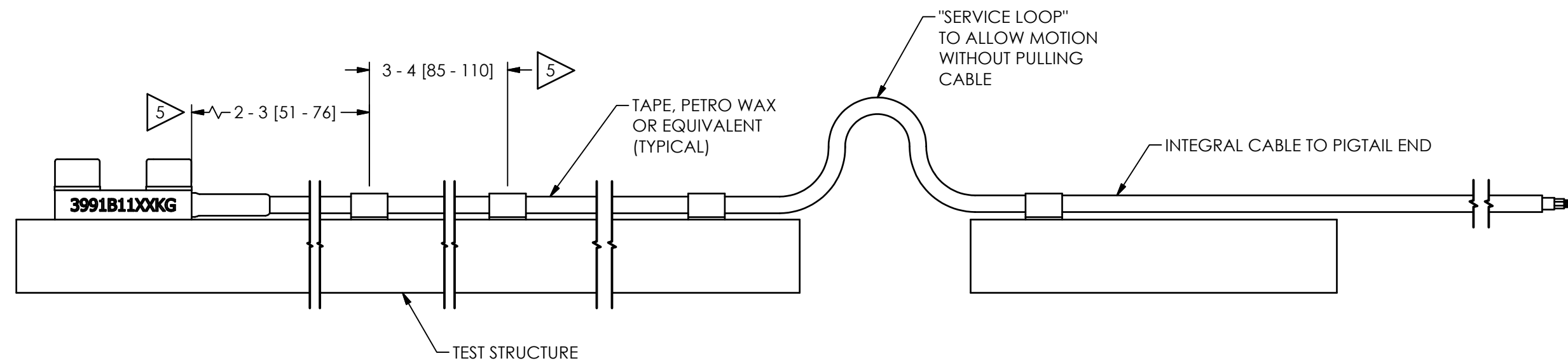

5 FASTEN CABLE TO TEST STRUCTURE TYPICALLY WITHIN 2-3"[51-76] OF SENSOR. THEN FASTEN AGAIN WITHIN 3-4"[76-101] OF PREVIOUS ATTACHMENT. BETWEEN THE TEST STRUCTURE AND A FIXED STRUCTURE, ALLOW A SERVICE LOOP LARGE ENOUGH TO PREVENT PULLING OF THE CABLE WHEN SHAKING. MORE ATTACHMENT POINTS WILL PROVIDE LESS NOISE IN THE RESULTING DATA. LOOSE CABLES OR PARTS ELSEWHERE ON THE TEST STRUCTURE CAN ALSO GENERATE "NOISE" ON THE SIGNAL RECEIVED FROM THE MODEL 3991 SERIES.

UNLESS OTHERWISE SPECIFIED TOLERANCES ARE:		DRAWN		CHECKED		ENGINEER	
DIMENSIONS IN INCHES	DIMENSIONS IN MILLIMETERS [IN BRACKETS]	KRM	4/3/18	KRM	4/3/18	GCD	4/3/18
DECIMALS XX ±.01 XXX ±.005	DECIMALS X ±.03 XX ±.013	TITLE INSTALLATION DRAWING MODEL 3991B11XXKG ACCELEROMETER					
ANGLES ± 2 DEGREES	ANGLES ± 2 DEGREES						
FILLETS AND RADII .003 - .005	FILLETS AND RADII 0.07 - 0.13	CODE IDENT. NO. 52681		DWG. NO. 65879		SCALE: 4X SHEET 2 OF 2	

PCB PIEZOTRONICS
 3425 WALDEN AVE. DEPEW, NY 14043
 (716) 684-0001 E-MAIL: sales@pcb.com