



Model 421B31

Differential charge amplifier for Dynamic acceleration sensors to be used with 10pC/g sensors

Installation and Operating Manual

**For assistance with the operation of this product,
contact the PCB Piezotronics, Inc.**

Toll-free: 716-684-0001

24-hour SensorLine: 716-684-0001

Fax: 716-684-0987

E-mail: info@pcb.com

Web: www.pcb.com



Series 421B3X Differential Input Charge Amplifier



Installation and Operating Manual

PCB Piezotronics, Inc.

3425 Walden Avenue, Depew, New York 14043-2495

24-Hour SensorLineSM 716 684-0001

Fax 716 684-0987

Toll Free (USA) 1-800-828-8840

E-Mail info@pcb.com



Table of Contents

Introduction	3
Description.....	3
Installation	3
Wiring and Operation	4
Calculation of Gain.....	5
Structural Diagram.....	6
Ordering Information.....	7
Special Considerations.....	7
Use with High Temperature Sensors	7
ESD Warning Information.....	8
Warning 1 – ESD sensitivity.....	8
Warning 2 – ESD sensitivity.....	8
Caution 1 – ESD sensitivity	8
Caution 2 – ESD sensitivity.....	8
Warranty	9
Service	9
Return Procedure	10
Customer Service.....	10

Introduction

The 421B3X-Series Differential Charge Amplifiers are designed to convert the high-impedance output of a differential, charge-mode piezoelectric sensor to a low-impedance voltage output. These amplifiers may be used with either quartz or ceramic, differential charge-mode piezoelectric sensors.

Description

The amplifier operates on a 22 to 28 VDC power supply. The amplifier employs a high gain amplifier to perform the impedance transformation. The output of the amplifier may be in voltage (mV) or current (μA) and may be scaled in terms of acceleration (g), pressure (psi or mbar) or velocity (in/s or mm/s). The electronic circuitry of the amplifier is incorporated into a molded aluminum enclosure. The amplifier has factory-configurable high-pass and low-pass filters. Furthermore, RFI filters protect the input and output against radio-frequency interference and other electromagnetic influences.

The amplifier is available in three variations, as noted in the table below.

Model	Sensor Type	Input	Output	High Pass Filter (-3dB)	Low Pass Filter (-1dB)
421B30	Pressure Sensor	17 pC/psi	350 mV/psi or $\mu\text{A}/\text{psi}$	10 Hz	5 kHz
421B31	Accelerometer	10 pC/g	100 mV/g or $\mu\text{A}/\text{g}$	10 Hz	1 kHz
421B3X	Pressure Sensor or Accelerometer	Configurable	Configurable	Configurable	Configurable

Installation

Mount the base of the amplifier to a flat surface near the sensor, with the amplifier's input as close to the sensor as possible. The cable length between the sensor and the amplifier should be as short as possible to reduce the introduction of triboelectric noise into the system.

The 421B3X-Series housing is connected to the common (-) terminals. Therefore, the amplifier must be mounted so that the housing is isolated from ground.

Wiring and Operation

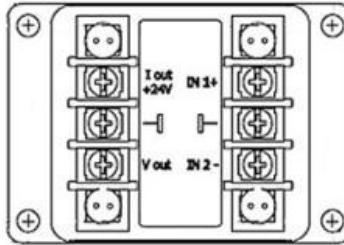

Terminal	Current Output	Voltage Output
I out +24V	Current Output/Power Input	Power Input
⊥	Common	
V out	No Connection	Voltage Output
IN 1+	Sensor Positive Input Signal	
⊥	Sensor Shield	
IN 2-	Sensor Negative Input Signal	

Input Signal:

- **Differential Piezoelectric Sensor:** Connect the sensor's positive charge output to the positive input (IN1+) and the sensor's negative charge output to negative input (IN2-) using low-noise cable.
- **Non-Differential Piezoelectric Sensor:** Connect the sensor output to the negative input (IN2-) and short the positive input (IN1+) and common (⊥) using low-noise cable. The output signal will be inverted when operating with a non-differential sensor.

Output Signal:

- **Voltage Output (mV):** The output of the amplifier (V out) should be routed to any readout device using standard coaxial or two-wire cable. The readout device may be an oscilloscope or other monitoring device. The output from the amplifier will be an AC signal proportional to the signal seen by the sensor.
- **Current Output (μA):** A CVLD power supply that provides a voltage within the specified required supply voltage of the amplifier should be used for current mode operation. The output of the CVLD receiver will be a voltage proportional to the V/mA sensitivity of the receiver. A CVLD receiver is the preferred current mode configuration. Alternatively, a current sense resistor can be placed in series on the standard coaxial or two-wire cable running from the output of the amplifier (I out/+24V) to the power supply. See diagram below of the current mode operation with series resistor. From this resistor, a voltage output can be routed to any readout device. The voltage output across the resistor is proportional to the current output per Ohm's law ($V = IR$). In this configuration the measured voltage will be inverted relative to the current output of the amplifier. For both configurations the readout device may be an oscilloscope or other monitoring device. The output from the amplifier will be an AC signal proportional to the signal seen by the sensor.

Note: The value of the resistor must be $\leq 250 \Omega$ and the input voltage (the node labeled POWER in the diagram below) must be $\geq 22\text{VDC}$. If a larger resistor value is used, this will cause the unit to not work properly and/or will limit the maximum output current.

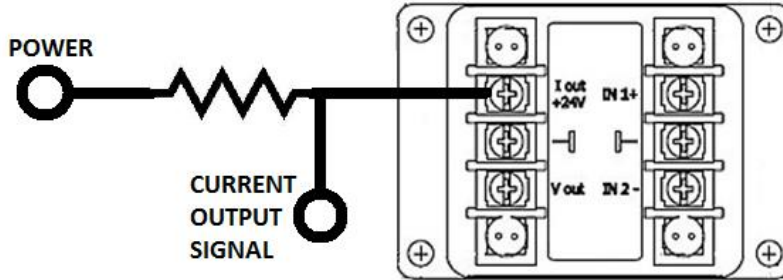

Calculation of Gain

An amplifier is selected by specifying an input sensitivity and an output sensitivity. As a result, the gain is inherently determined without specifically calling it out. The gain of the amplifier can be calculated using one of the following equations:

		Input Sensitivity Units		
		<u>pC</u> /bar	<u>pC</u> /psi	<u>pC</u> /g
Output Sensitivity Units	mV/mbar	$\frac{(\text{Output} \times 1000)}{\text{Input}}$	$\frac{(\text{Output} \times 68.9475)}{\text{Input}}$	N/A
	mV/psi	$\frac{(\text{Output} \times 14.5037)}{\text{Input}}$	$\frac{\text{Output}}{\text{Input}}$	N/A
	mV/g	N/A	N/A	$\frac{\text{Output}}{\text{Input}}$
	mV/mm/s	N/A	N/A	$\frac{(\text{Output} \times 9806.6) / (2 \times \pi \times f)}{\text{Input}}$
	mV/ <u>ips</u>	N/A	N/A	$\frac{(\text{Output} \times 386.1) / (2 \times \pi \times f)}{\text{Input}}$

Note:

- Current output in μA always equals voltage output in mV.
- For velocity output models, the gain of the amplifier is frequency (f) dependent.

Example: An amplifier ordered with 10 pC/g input sensitivity and a 100 mV/g output sensitivity would have a gain of $100 \text{ mV/g} / 10 \text{ pC/g} = 10 \text{ mV/pC}$.

Structural Diagram

The amplifier structural diagram is shown below:

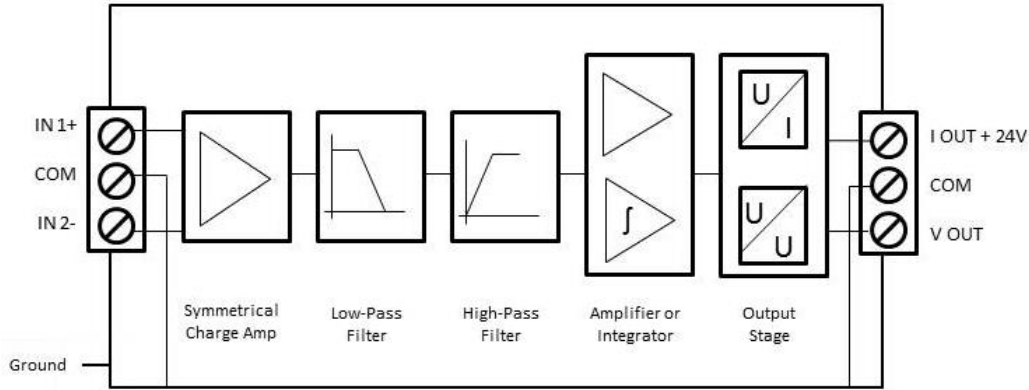

The amplifier converts the charge-based signal from a piezoelectric transducer into a current and voltage signal.

- **Current Output:** The current signal is transmitted to the processing electronics via a 2-wire transmission cable. Two-wire current output is provided by power input/current output (Iout/+24V) and common (I-) terminals. The current output allows transmission over a maximum distance of 3,000 feet. A CVLD power supply as described in the Wiring and Operation section is recommended for this configuration.
- **Voltage Output:** The voltage signal is transmitted to the processing electronics via a 3-wire transmission cable. Three-wire voltage output is provided by power input/current output (Iout/+24V), common (I-) and voltage output (Vout) terminals. The voltage output allows transmission over a maximum distance of 100 feet (without analysis of cable capacitance).

Ordering Information

To configure a 421B3X-Series amplifier, construct a full model number according to the below scheme.

MODEL	INPUT SENSITIVITY					OUTPUT SENSITIVITY					FILTERS				
	Value				Units	Value				Units	High-Pass		Low-Pass		
	A	A	A	A	B	C	C	C	C	D	E	E	F	F	F
421B3X	0001-1000				G/B/P	0001-5000				G/I/M/P/B	X5-10		002-200		
	0001-0200 pC/g 0001-1000 pC/bar 0001-0100 pC/psi				G=g B=bar P=psi	0010-2000 mV/g 1000-5000 mV/in/s (1-5 in/s full scale) 0010-0100 mV/mm/s 0001-1000 mV/psi 0001-0010 mV/mbar				G=g I=in/s M=mm/s P=psi B=mbar	X5=0.5 Hz 01=1 Hz 02=2 Hz 05=5 Hz 10=10 Hz		002=200 Hz 005=500 Hz 010=1 kHz 020=2 kHz 050=5 kHz 100=10 kHz 200=20 kHz		

Full Model Number for Pre-Configured Models:

- 421B30 for Use with Pressure Sensor = 421B3X-0017-P-0350-P-10-050
- 421B31 for Use with Accelerometer = 421B3X-0010-G-0100-G-10-010

Special Considerations

High source capacitance may degrade the performance of the amplifier. Source capacitance is the input capacitance to the amplifier defined as transducer capacitance plus cable capacitance. If the source capacitance is increased due to a long length of cable, amplifier noise will increase and frequency response will decrease.

Low frequency response is 10 Hz when used in current output configuration.

Use with High Temperature Sensors

The amplifier is specifically designed for use with piezoelectric sensors with an operating temperature range of greater than 500 °F (260 °C), which typically have lower insulation resistance values. The amplifier will operate with insulation resistances as low as 50 kOhm.

Note: When using the 421B3X series differential charge amplifier with high temperature sensors, the unit may have a longer turn-on time than typical charge amplifiers which are designed for use with sensors with high insulation resistance.

Caution! Excessive accumulated charges on the input cables can destroy the field effect transistor (FET) in the amplifier. These charges can be grounded before connection by shorting the center pin on the cable connector plug to its knurled nut with any metallic object.

ESD Warning Information

Warning 1 – ESD sensitivity

The 421B3X Series Differential Charge Amplifier should be opened by PCB factory-qualified personnel only. This product is intended for use by qualified personnel who recognize shock hazards and are familiar with the safety precautions required to avoid injury.

Warning 2 – ESD sensitivity

This equipment is designed with user safety in mind; however, the protection provided by the equipment may be impaired if the equipment is used in a manner not specified by PCB Piezotronics, Inc.

Caution 1 – ESD sensitivity

Cables can kill your equipment. Although 421 series differential charge amplifiers have protection, they can still be damaged by high level voltage from electrostatic discharge (ESD). Similar to a capacitor, a cable can hold a charge caused by triboelectric transfer, such as that which occurs in the following:

- Laying on and moving across a rug,
- Any movement through air,
- The action of rolling out a cable, and/or
- Contact with a non-grounded person.

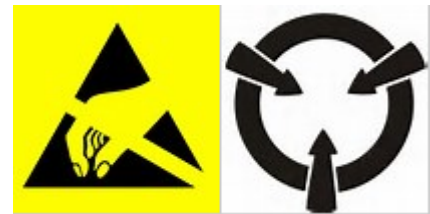

**CAUTION ELECTROSTATIC
DISCHARGE SENSITIVE**

The PCB solution for product safety:

- Connect the cables only with the AC power off.
- Temporarily "short" the end of the cable before attaching it to any signal input or output.

Caution 2 – ESD sensitivity

ESD considerations should be made prior to performing any internal adjustments on the equipment. Any item of electronic equipment is vulnerable to ESD when opened for adjustments. Internal adjustments should therefore be done **ONLY** at an ESD-safe work area. Many products have ESD protection, but the level of protection may be exceeded by extremely high voltage.

Warranty

A. Total Customer Satisfaction. PCB guarantees **Total Customer Satisfaction** through its “Lifetime Warranty Plus” on all Platinum Stock Products sold by PCB and through its Limited Warranties on all other PCB Stock, Standard and Special products.

B. Platinum Stock Products – Lifetime Warranty Plus. Under PCB’s Lifetime Warranty Plus, if any PCB Platinum Stock Product ever fails, PCB will repair, replace or exchange the product at no charge. As a further benefit under PCB’s Lifetime Warranty Plus, PCB will, for a one (1) year period following the delivery date of any PCB Platinum Stock product, refund 100% of the customer’s purchase price paid for any such Product with which the original purchaser is not completely satisfied. This option of a refund may be selected in lieu of the repair, replacement or exchange of the product. “Platinum Stock Product” is defined as any PCB Stock Product designated by PCB from time-to-time as a “Platinum” model.

C. Stock Products – Limited Warranty. PCB warrants that all PCB Stock Products will be free from defects in materials and workmanship for a period of two (2) years from the date of original purchase. If any Stock Product shall fail during the warranty period, PCB will repair, replace or exchange it without charge. As a further benefit under PCB’s Limited Warranty for Stock Products, PCB will, for a (1) year period following the delivery date of any PCB Stock Product, refund 100% of the customer’s purchase price for any PCB Stock Product with which the original purchaser is not completely satisfied. “Stock Product” is defined to mean any product designated by PCB from time-to-time as a “Stock Product”. This is generally a product on which PCB customarily maintains finished goods inventory.

D. Standard Products, Special Products and Test and Measurement Cables – Limited Warranty. PCB warrants that all PCB Standards, PCB Specials and test and measurement cables will be free from defects in materials and workmanship for a period of one (1) year from the date of original purchase. If any PCB Standard or PCB Special shall fail during the warranty period, PCB will repair, replace or exchange it without charge. “PCB Standard” is a product regularly manufactured by PCB for which PCB does not customarily maintain finished goods inventory. “PCB Special” is defined as any customized or modified PCB product for which PCB does not customarily maintain finished goods inventory, or any other product PCB classifies as a special from time to time.

Service

Because of the sophisticated nature of PCB instrumentation, field repair is typically not recommended and may void any warranty. If factory service is required, return the instrumentation according to the "Return Procedure" stated below. A repair and/or replacement quotation will be provided prior to servicing at no charge. Before returning the unit, please consult a factory PCB applications engineer concerning the situation because certain problems can often be corrected with simple on-site procedures.

Return Procedure

To expedite returned instrumentation, contact a factory PCB Customer Service Representative for a RETURN MATERIAL AUTHORIZATION (RMA) NUMBER. When calling, please have information such as model, serial number and description of the problem available. When preparing the package for return, it is helpful to provide a written description of the symptoms and problems experienced with the equipment.

Customers outside the U.S. should consult their local PCB distributor for information on returning equipment. For exceptions, please contact the International Sales department at PCB to request shipping instructions and an RMA. For assistance, please call (716) 684-0003, or fax us at (716) 684-3823. You may also receive assistance via e-mail at <mailto:imi@pcb.com> or visit our web site at <http://www.pcb.com/>.

Customer Service

PCB guarantees **Total Customer Satisfaction**. If, at any time, for any reason, you are not completely satisfied with any PCB product, PCB will repair, replace, or exchange it at no charge. You may also choose, within the warranty period, to have your purchase price refunded.

PCB offers to all customers, at no charge, 24-hour phone support. This service makes product or application support available to our customers, day or night, seven days a week. When unforeseen problems or emergency situations arise, call the **24 Hour SensorLineSM at 716 684-0001**, and an application specialist will assist you.



3425 Walden Avenue, Depew, NY 14043-2495
Phone 716 684-0001 **Fax** 716 684-0987 **E-Mail** info@pcb.com
PCB www.PCB.com **IMI** www.IMI-Sensors.com

Certified to ISO 9001, AS-9100, ISO/IEC 17025

© 2013 PCB Group, Inc. In the interest of constant product improvement, specifications are subject to change without notice. All prices are subject to change without notice. PCB, ICP and Modally Tuned are registered trademarks of PCB Group, Inc. IMI and SensorLine are service marks of PCB Group, Inc. All other trademarks are properties of their respective owners.

PCB Piezotronics Inc. claims proprietary rights in the information disclosed hereon. Neither it nor any reproduction thereof will be disclosed to others without the written consent of PCB Piezotronics Inc.

REVISIONS		
REV	DESCRIPTION	DIN
NR	RELEASED TO DRAFTING	49931

70283

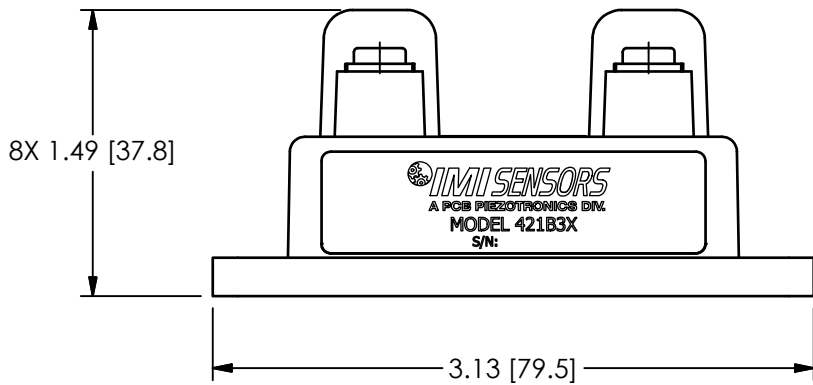
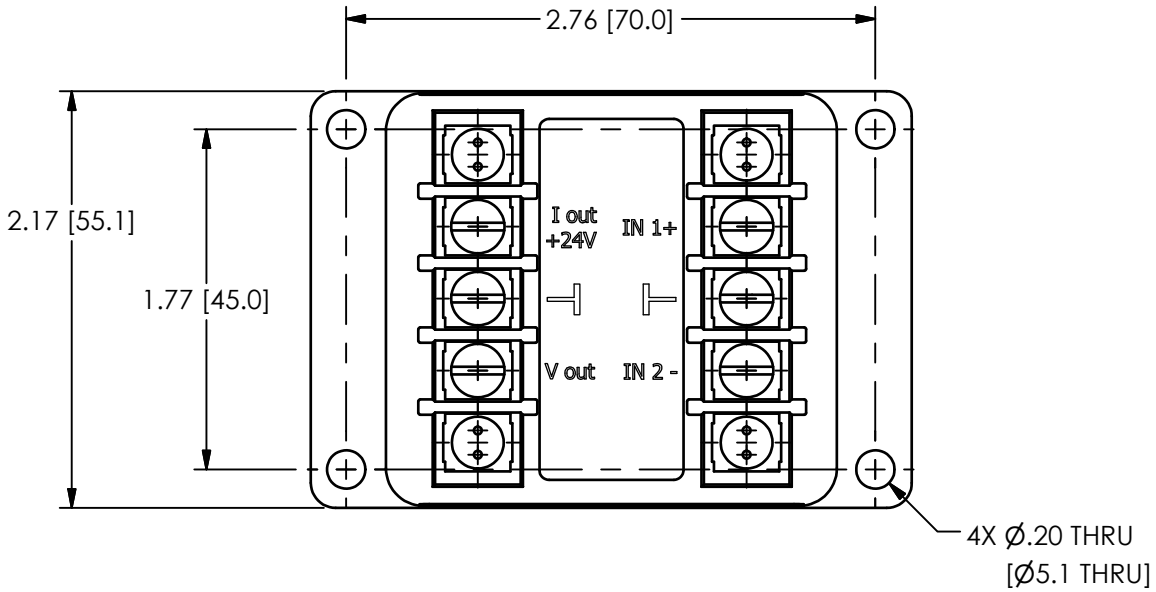

UNLESS OTHERWISE SPECIFIED TOLERANCES ARE:		DRAWN		CHECKED		ENGINEER		 3425 WALDEN AVE. DEPEW, NY 14043 (716) 684-0001 E-MAIL: sales@pcb.com	
DIMENSIONS IN INCHES	DIMENSIONS IN MILLIMETERS [IN BRACKETS]	JES	10/28/19	JDM	10/28/19	AJP	10/28/19		
DECIMALS XX ±.03 XXX ±.010	DECIMALS X ± 0.8 XX ± 0.25	TITLE OUTLINE DRAWING MODEL 421B3X CHARGE AMPLIFIER							CODE IDENT. NO. 52681
ANGLES ± 2 DEGREES	ANGLES ± 2 DEGREES								DWG. NO. 70283
FILLETS AND RADII .003 - .005	FILLETS AND RADII 0.07 - 0.13	SCALE: FULL		SHEET 1 OF 1					