

PCB Piezotronics Inc. claims proprietary rights in the information disclosed hereon. Neither it nor any reproduction thereof will be disclosed to others without the written consent of PCB Piezotronics Inc.

REVISIONS

REV	DESCRIPTION	DIN
A	UPDATED THREAD CALLOUT	38594

51519

MOUNTING STUD (SUPPLIED):

ENGLISH: (PT NO: 22680-01)  
CAP SCREW 1/4-28 X 3/8

METRIC: (PT NO: 26676-01)  
CAP SCREW M6 X 0.75 X 10

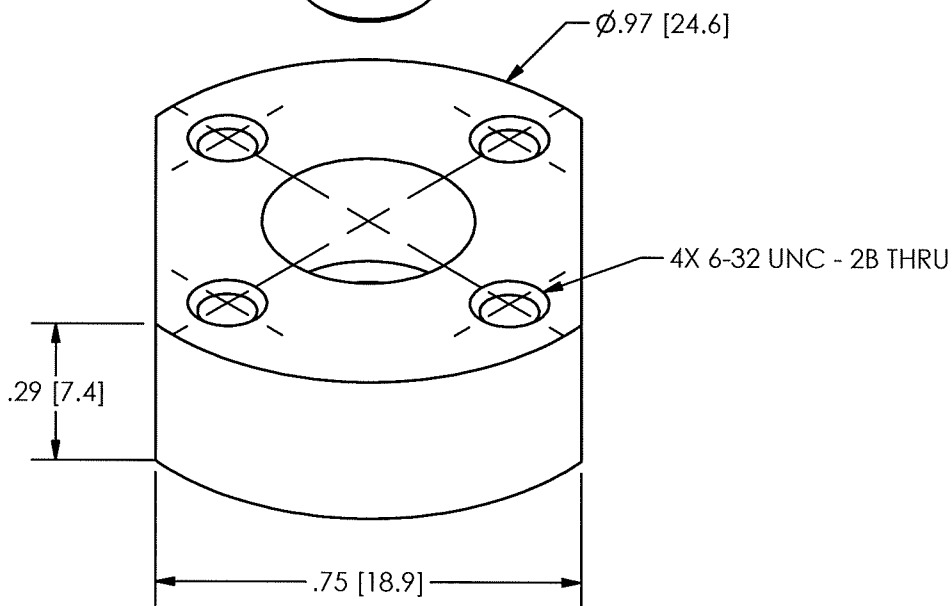
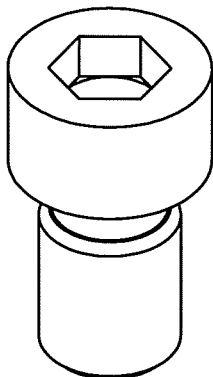

UNLESS OTHERWISE SPECIFIED TOLERANCES ARE:

DRAWN		CHECKED		ENGINEER	
JDM	3/2/12	ECB	3-12	SMB	3/2/12



3425 WALDEN AVE. DEPEW, NY 14043  
(716) 684-0001 E-MAIL: sales@pcb.com

DIMENSIONS IN INCHES	DIMENSIONS IN MILLIMETERS [IN BRACKETS]
DECIMALS XX ±.03 XXX ±.010	DECIMALS X ± 0.8 XX ± 0.25
ANGLES ± 2 DEGREES	ANGLES ± 2 DEGREES
FILLETS AND RADII .003 - .005	FILLETS AND RADII 0.07 - 0.13

TITLE  
OUTLINE DRAWING  
MODEL 080B197  
MOUNTING ADAPTOR

CODE IDENT. NO. 52681	DWG. NO. 51519
SCALE: 3X	SHEET 1 OF 1