

5609

PCB Piezotronics Inc. claims proprietary rights in the information disclosed hereon. Neither it nor any reproduction thereof will be disclosed to others without written consent of PCB Piezotronics Inc.

APPLICATION		
NEXT ASS'Y	USED ON	VAR

REVISIONS				
REV	DESCRIPTION	ECN	DATE	APP'D

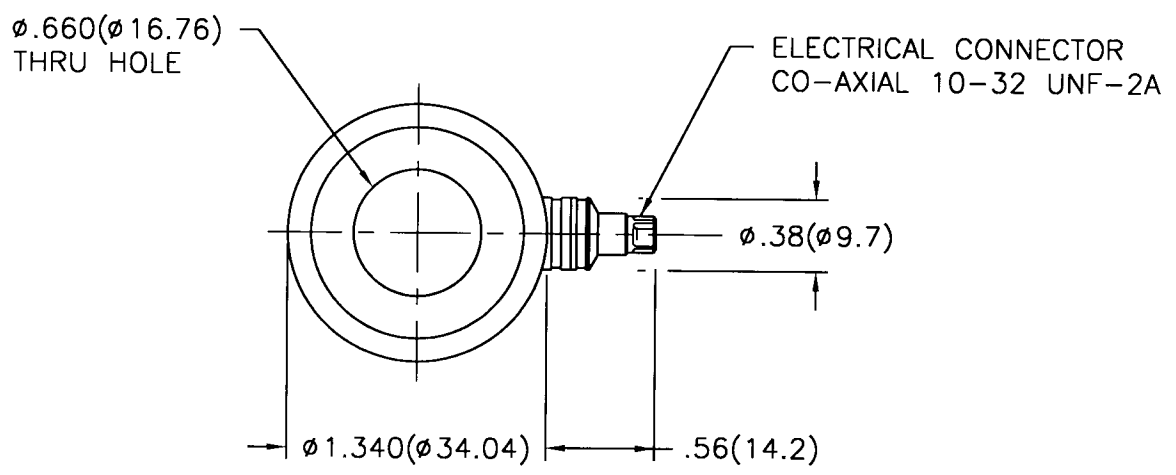

MODEL 082B04
ANTI-FRICTION
WASHER
(SUPPLIED)

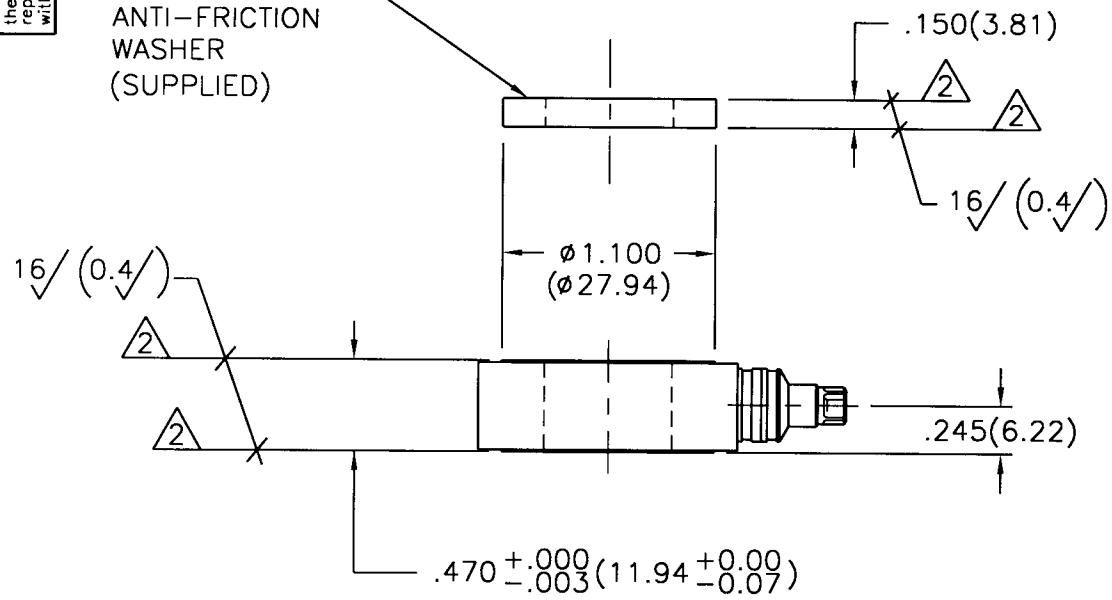

2 THESE SURFACES TO BE FLAT AND PARALLEL TO WITHIN .001(0.03) TIR.
1.) SEE SHEET TWO FOR MOUNTING INSTRUCTIONS.

UNLESS SPECIFIED TOLERANCES		DRAWN		MFG		PCB PIEZOTRONICS, INC. 3425 WALDEN AVE. DEPEW, NEW YORK 14043 PHONE: (716) 684-0001
DIMENSIONS IN INCHES	DIMENSIONS IN MILLIMETERS (IN PARENTHESIS)	CHK'D	DATE	ENGR	DATE	
DECIMALS XX ±.01 XXX ±.005	DECIMALS XX ±0.3 XXX ±0.13	APP'D	DATE	DATE	DATE	
ANGLES ±2 DEGREES	ANGLES ±2 DEGREES	TITLE		CODE IDENT. NO.	DWG. NO.	
FILLETS AND RADII .003 - .005	FILLETS AND RADII (0.07 - 0.13)	INSTALLATION DRAWING MODEL M204C FORCE RING		52681	5609	
DD011 REV. A 05/26/95				SCALE: FULL	SHEET 1 OF 2	

5609

PCB Piezotronics Inc. claims proprietary rights in the information disclosed hereon. Neither it nor any reproduction thereof will be disclosed to others without written consent of PCB Piezotronics Inc.

APPLICATION		
NEXT ASS'Y	USED ON	VAR

REVISIONS				
REV	DESCRIPTION	ECN	DATE	APP'D
-SEE SHEET ONE-				

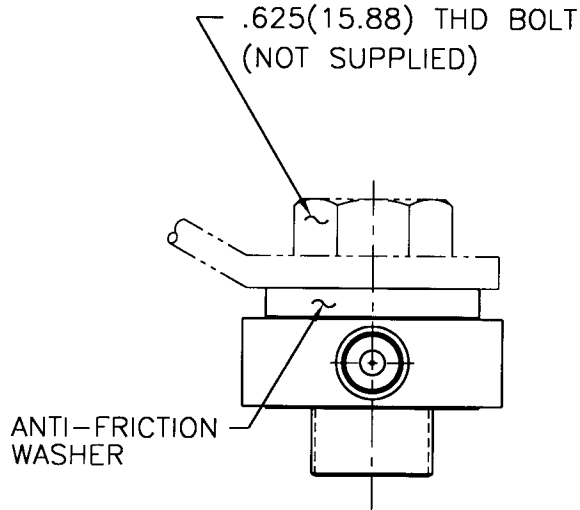

TYP BOLT MOUNTING
INSTALLATION

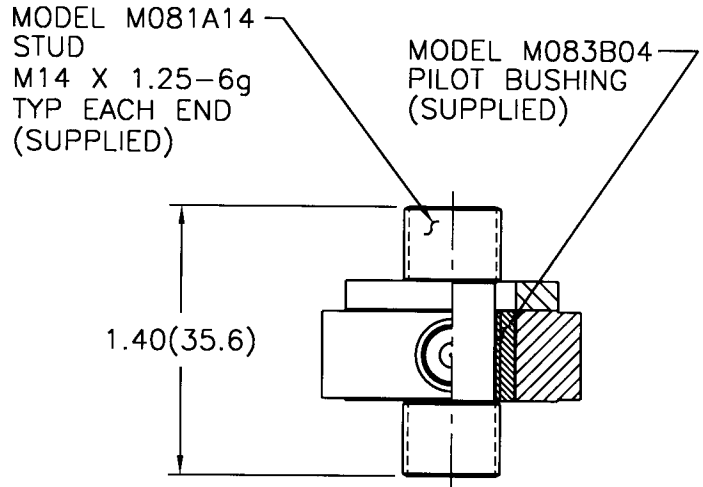

TYP STUD MOUNTING
INSTALLATION

DRILL & TAP $\triangle 4$
AS REQUIRED
FOR .625(15.88)
THD BOLT

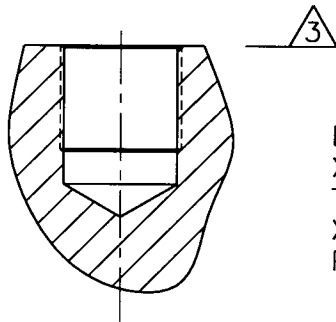

DRILL $\phi .500(\phi 12.70)$ $\triangle 4$
X .62(15.8) ∇
TAP M14 X 1.25-6g
X .50(12.7) ∇
PERFECT THREAD

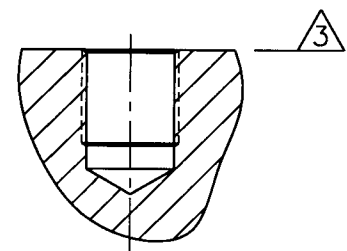

5.) SEE MANUAL FOR PRELOAD INSTRUCTIONS.

$\triangle 4$ DRILL PERPENDICULAR TO MOUNTING SURFACE TO WITHIN $\pm .001^\circ$.

$\triangle 3$ MOUNTING SURFACE UNDER FORCE RING MUST BE FLAT WITHIN .001(0.03) TIR WITH A $63\sqrt{1.6}$ FINISH.

UNLESS SPECIFIED TOLERANCES		DRAWN	CHK'D	APP'D	MFG	ENGR	DATE	PCB PIEZOTRONICS, INC. 3425 WALDEN AVE. DEPEW, NEW YORK 14043 PHONE: (716) 684-0001	
DIMENSIONS IN INCHES	DIMENSIONS IN MILLIMETERS (IN PARENTHESIS)								
DECIMALS XX $\pm .01$ XXX $\pm .005$	DECIMALS XX ± 0.3 XXX ± 0.13								
ANGLES ± 2 DEGREES	ANGLES ± 2 DEGREES								
FILLETS AND RADII .003 - .005	FILLETS AND RADII (0.07 - 0.13)	TITLE INSTALLATION DRAWING MODEL M204C FORCE RING						CODE IDENT. NO. 52681	DWG. NO. 5609
DD011 REV. A 05/26/95								SCALE: FULL	SHEET 2 OF 2