



Model 682A14

ICP 4-20 mA transmitter

Installation and Operating Manual

**For assistance with the operation of this product,
contact the PCB Piezotronics, Inc.**

Toll-free: 800-959-4464

24-hour SensorLine: 716-684-0001

Fax: 716-684-3823

E-mail: imi@pcb.com

Web: www.imi-sensors.com



Repair and Maintenance

PCB guarantees Total Customer Satisfaction through its “Lifetime Warranty Plus” on all Platinum Stock Products sold by PCB and through its limited warranties on all other PCB Stock, Standard and Special products. Due to the sophisticated nature of our sensors and associated instrumentation, **field servicing and repair is not recommended and, if attempted, will void the factory warranty.**

Beyond routine calibration and battery replacements where applicable, our products require no user maintenance. Clean electrical connectors, housings, and mounting surfaces with solutions and techniques that will not harm the material of construction. Observe caution when using liquids near devices that are not hermetically sealed. Such devices should only be wiped with a dampened cloth—never saturated or submerged.

In the event that equipment becomes damaged or ceases to operate, our Application Engineers are here to support your troubleshooting efforts 24 hours a day, 7 days a week. Call or email with model and serial number as well as a brief description of the problem.

Calibration

Routine calibration of sensors and associated instrumentation is necessary to maintain measurement accuracy. We recommend calibrating on an annual basis, after exposure to any extreme environmental influence, or prior to any critical test.

PCB Piezotronics is an ISO-9001 certified company whose calibration services are accredited by A2LA to ISO/IEC 17025, with full traceability to SI through N.I.S.T. In addition to our standard calibration services, we also offer specialized tests, including: sensitivity at elevated or cryogenic temperatures, phase response, extended high or low frequency response, extended range, leak testing, hydrostatic pressure testing, and others. For more information, contact your local PCB Piezotronics distributor, sales representative, or factory customer service representative.

Returning Equipment

If factory repair is required, our representatives will provide you with a Return Material Authorization (RMA) number, which we use to reference any information you have already provided and expedite the repair process. This number should be clearly marked on the outside of all returned package(s) and on any packing list(s) accompanying the shipment.

Contact Information

PCB Piezotronics, Inc.
3425 Walden Ave.
Depew, NY14043 USA
Toll-free: (800) 828-8840
24-hour SensorLine: (716) 684-0001
General inquiries: info@pcb.com
Repair inquiries: rma@pcb.com

For a complete list of distributors, global offices and sales representatives, visit our website, www.pcb.com.

Safety Considerations

This product is intended for use by qualified personnel who recognize shock hazards and are familiar with the precautions required to avoid injury. While our equipment is designed with user safety in mind, the protection provided by the equipment may be impaired if equipment is used in a manner not specified by this manual.

Discontinue use and contact our 24-Hour Sensorline if:

- Assistance is needed to safely operate equipment
- Damage is visible or suspected
- Equipment fails or malfunctions

For complete equipment ratings, refer to the enclosed specification sheet for your product.

Definition of Terms and Symbols

The following symbols may be used in this manual:



DANGER

Indicates an immediate hazardous situation, which, if not avoided, may result in death or serious injury.

**CAUTION**

Refers to hazards that could damage the instrument.

**NOTE**

Indicates tips, recommendations and important information. The notes simplify processes and contain additional information on particular operating steps.

The following symbols may be found on the equipment described in this manual:



This symbol on the unit indicates that high voltage may be present. Use standard safety precautions to avoid personal contact with this voltage.



This symbol on the unit indicates that the user should refer to the operating instructions located in the manual.



This symbol indicates safety, earth ground.



PCB工业监视和测量设备 - 中国RoHS2公布表

PCB Industrial Monitoring and Measuring Equipment - China RoHS 2 Disclosure Table

部件名称	有害物质					
	铅 (Pb)	汞 (Hg)	镉 (Cd)	六价铬 (Cr(VI))	多溴联苯 (PBB)	多溴二苯醚 (PBDE)
住房	0	0	0	0	0	0
PCB板	X	0	0	0	0	0
电气连接器	0	0	0	0	0	0
压电晶体	X	0	0	0	0	0
环氧	0	0	0	0	0	0
铁氟龙	0	0	0	0	0	0
电子	0	0	0	0	0	0
厚膜基板	0	0	X	0	0	0
电线	0	0	0	0	0	0
电缆	X	0	0	0	0	0
塑料	0	0	0	0	0	0
焊接	X	0	0	0	0	0
铜合金/黄铜	X	0	0	0	0	0
本表格依据 SJ/T 11364 的规定编制。						
0：表示该有害物质在该部件所有均质材料中的含量均在 GB/T 26572 规定的限量要求以下。						
X：表示该有害物质至少在该部件的某一均质材料中的含量超出 GB/T 26572 规定的限量要求。						
铅是欧洲RoHS指令2011/65/ EU附件三和附件四目前由于允许的豁免。						

CHINA RoHS COMPLIANCE

Component Name	Hazardous Substances					
	Lead (Pb)	Mercury (Hg)	Cadmium (Cd)	Chromium VI Compounds (Cr(VI))	Polybrominated Biphenyls (PBB)	Polybrominated Diphenyl Ethers (PBDE)
Housing	O	O	O	O	O	O
PCB Board	X	O	O	O	O	O
Electrical Connectors	O	O	O	O	O	O
Piezoelectric Crystals	X	O	O	O	O	O
Epoxy	O	O	O	O	O	O
Teflon	O	O	O	O	O	O
Electronics	O	O	O	O	O	O
Thick Film Substrate	O	O	X	O	O	O
Wires	O	O	O	O	O	O
Cables	X	O	O	O	O	O
Plastic	O	O	O	O	O	O
Solder	X	O	O	O	O	O
Copper Alloy/Brass	X	O	O	O	O	O

This table is prepared in accordance with the provisions of SJ/T 11364.

O: Indicates that said hazardous substance contained in all of the homogeneous materials for this part is below the limit requirement of GB/T 26572.

X: Indicates that said hazardous substance contained in at least one of the homogeneous materials for this part is above the limit requirement of GB/T 26572.

Lead is present due to allowed exemption in Annex III or Annex IV of the European RoHS Directive 2011/65/EU.

Model Number
682A14

4-20 MA DIN RAIL SIGNAL CONDITIONER/TRANSMITTER

Revision: NR
ECN #: 50075

Performance

	ENGLISH	SI	
Channels	1	1	
Input Signal(Vibration)	± 100 mV/g	± 10.2 mV/(m/s ²)	[1]
Output Signal(DC Vibration)	4 to 20 mA	4 to 20 mA	[2]
Output Signal(AC Vibration)	100 mV/g	10.2 mV/(m/s ²)	[3]
Frequency Range(- 3 dB)(Velocity)	210 to 600,000 cpm	3.5 to 10k Hz	[4][5][6]
Output Range(DC Velocity)	0 to 1.00 in/sec pk	0 to 25.4 mm/s pk	[1]

Environmental

Temperature Range(Operating)	-13 to 158 °F	-25 to 70 °C
Temperature Range(Storage)	-40 to 257 °F	-40 to 125 °C
Humidity Range(Non-Condensing)	0 to 95 %	0 to 95 %

Electrical

Power Required	DC Power	DC Power
DC Power	23 to 25 VDC	23 to 25 VDC
DC Power(maximum)	100 mA	100 mA
Settling Time	< 2 min	< 2 min
Excitation Voltage(delivered to sensor)	19 to 21 VDC	19 to 21 VDC
Constant Current Excitation(delivered to sensor)	3 to 5 mA	3 to 5 mA
Output Span(± 5.0 %)(DC Vibration Current Output)	16 mA	16 mA

Physical

Electrical Connector(input/output)	Removable Screw Terminals	Removable Screw Terminals
Electrical Connector (raw vibration output)	BNC Jack	BNC Jack
Housing Material	Polyamide	Polyamide
Size (Height x Width x Depth)	3.9 in x 0.9 in x 4.5 in	99 mm x 22.5 mm x 114.5 mm
Weight(Maximum)	6.4 oz	127
Screw Terminal Wire Size	24-14 AWG	24-14 AWG
Din Rail Mount	1.38 in	35 mm
Status Indicator(Power "on")	Green LED	Green LED
Status Indicator (Input Fault)	Red LED	Red LED

OPTIONAL VERSIONS

Optional versions have identical specifications and accessories as listed for the standard model except where noted below. More than one option may be used.

NOTES:

- [1] Output measurement range is based upon input from 100 mV/g ICP® accelerometer and will be scaled inversely proportional to any percentage deviation of this input.
 [2] Output current voltage will fluctuate at frequencies below 5 Hz.
 [3] Achieved with 100 mV/g ICP® accelerometer input.
 [4] Attenuation is -40 dB/decade.
 [5] The low frequency tolerance is accurate within ± 0.5 Hz of the specified frequency.
 [6] The high frequency tolerance is accurate within ± 1.0 kHz of specified frequency.
 [7] See PCB Declaration of Conformance PS124 for details.



Entered: LK	Engineer: gs	Sales: MC	Approved: BAM	Spec Number:
Date: 10/30/2019	Date: 10/30/2019	Date: 10/30/2019	Date: 10/30/2019	72516

IMI SENSORS
A PCB PIEZOTRONICS DIV.
3425 Walden Avenue, Depew, NY 14043

Phone: 800-959-4464
Fax: 716-684-3823
E-Mail: imi@pcb.com

All specifications are at room temperature unless otherwise specified.
 In the interest of constant product improvement, we reserve the right to change specifications without notice.
 ICP® is a registered trademark of PCB Piezotronics, Inc.

PCB Piezotronics Inc. claims proprietary rights in the information disclosed hereon. Neither it nor any reproduction thereof will be disclosed to others without the written consent of PCB Piezotronics Inc.

68699

REVISIONS		
REV	DESCRIPTION	DIN
NR	RELEASED TO DRAFTING	48166

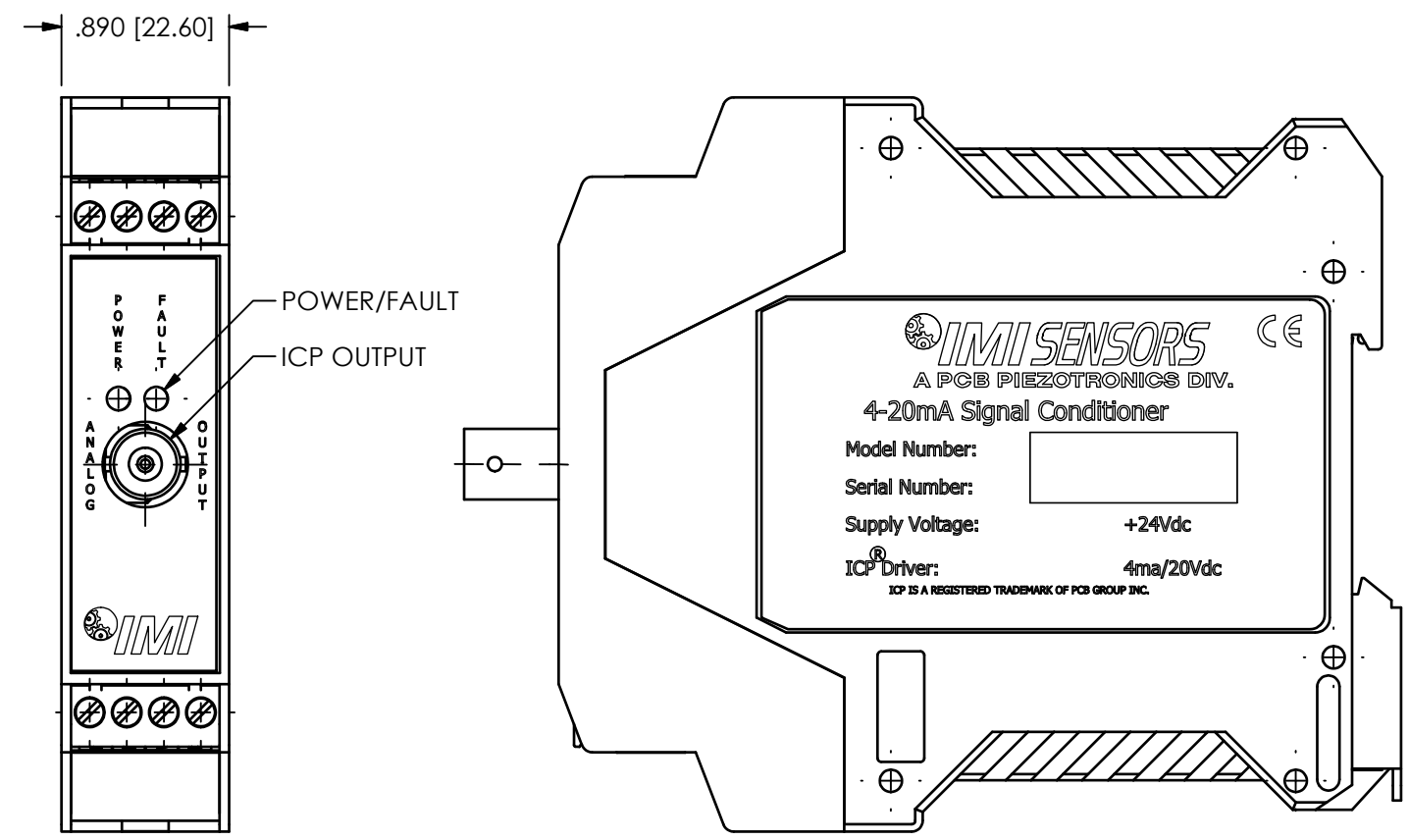
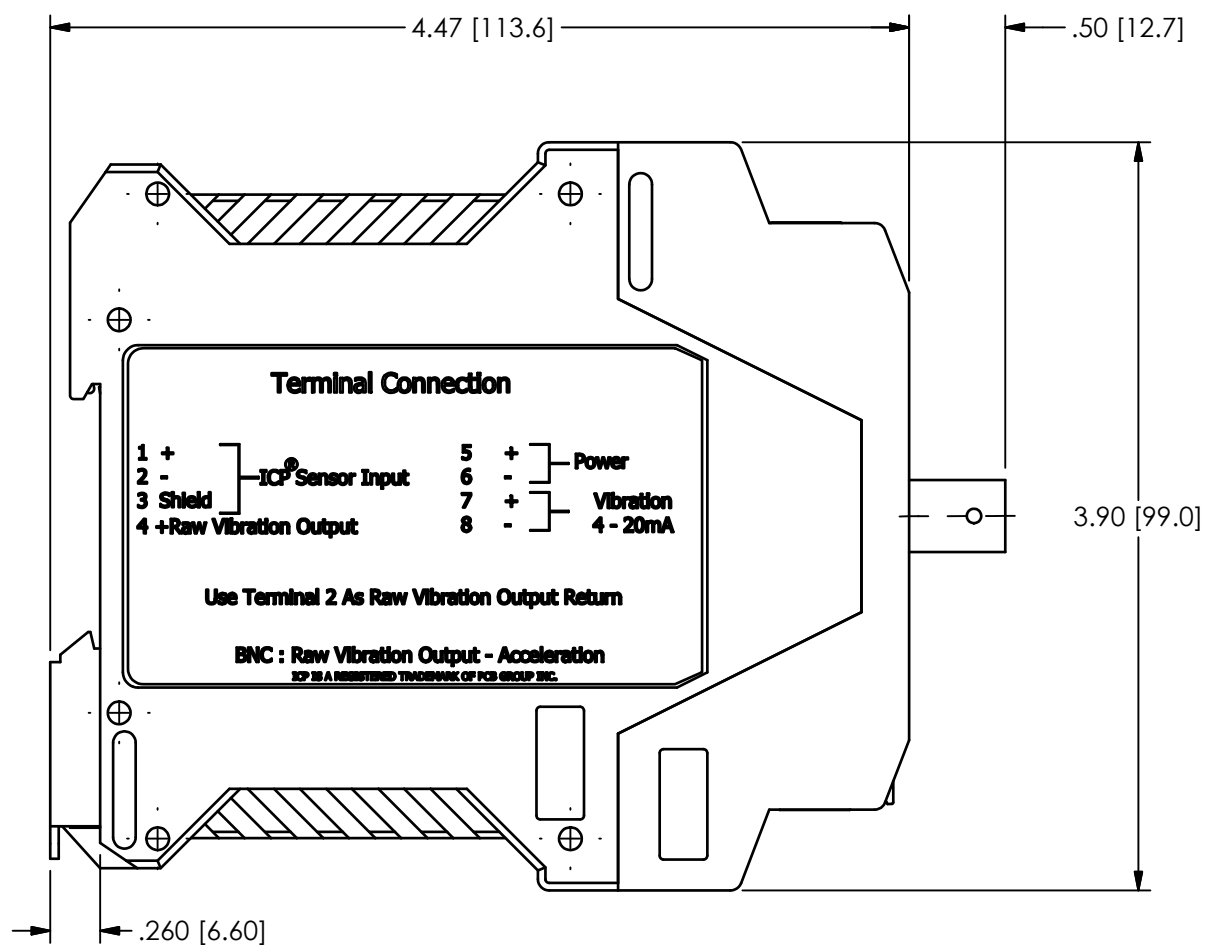

UNLESS OTHERWISE SPECIFIED TOLERANCES ARE:		DRAWN		CHECKED		ENGINEER	
DIMENSIONS IN INCHES	DIMENSIONS IN MILLIMETERS [IN BRACKETS]	KRM	5/23/18	KRM	5/23/18	GGG	5/23/18
DECIMALS XX ±.03 XXX ±.010	DECIMALS X ±0.8 XX ±0.25	TITLE OUTLINE DRAWING 4-20 DIN RAIL CONDITIONER					
ANGLES ± 2 DEGREES	ANGLES ± 2 DEGREES						
FILLETS AND RADII .003 - .005	FILLETS AND RADII 0.07 - 0.13	CODE IDENT. NO. 52681		DWG. NO. 68699		SCALE: FULL SHEET 1 OF 1	

PCB PIEZOTRONICS

3425 WALDEN AVE. DEPEW, NY 14043
(716) 684-0001 E-MAIL: sales@pcb.com

Model 682A14 & 682A15 4-20mA Din Rail ICP[®] Signal Conditioner

CE



Operating Guide with Enclosed Warranty Information

3425 Walden Avenue, Depew, New York 14043-2495

Phone (716) 684-0003

Fax (716) 684-3823

Toll Free Line 1-800-959-4IMI

**MANUAL NUMBER: 72514
MANUAL REVISION: NR
ECN NUMBER: 50075**

Table of Contents

<i>Introduction.....</i>	<i>Page 3</i>
<i> Block Diagram</i>	<i>Page 3</i>
<i> General Features.....</i>	<i>Page 4</i>
<i>Installation and Wiring</i>	<i>Page 5</i>
<i>Configuring the 682A14 & 682A15.....</i>	<i>Page 9</i>
<i>ESD Sensitivity.....</i>	<i>Page 10</i>

Warranty/Serviceing

<i>Warranty, Service & Return Procedure</i>	<i>Page 11</i>
<i>Customer Service.....</i>	<i>Page 12</i>

Introduction

Models 682A14 & 682A15 are 4-20mA din rail signal conditioners designed to interface with a 100 mV/g ICP® accelerometer.

The signal is integrated, filtered and scaled. The 4-20mA output signal is proportional to overall velocity with a measurement range of 0-1 ips rms when using the 682A15 and ips peak when using the 682A14.

Block Diagram

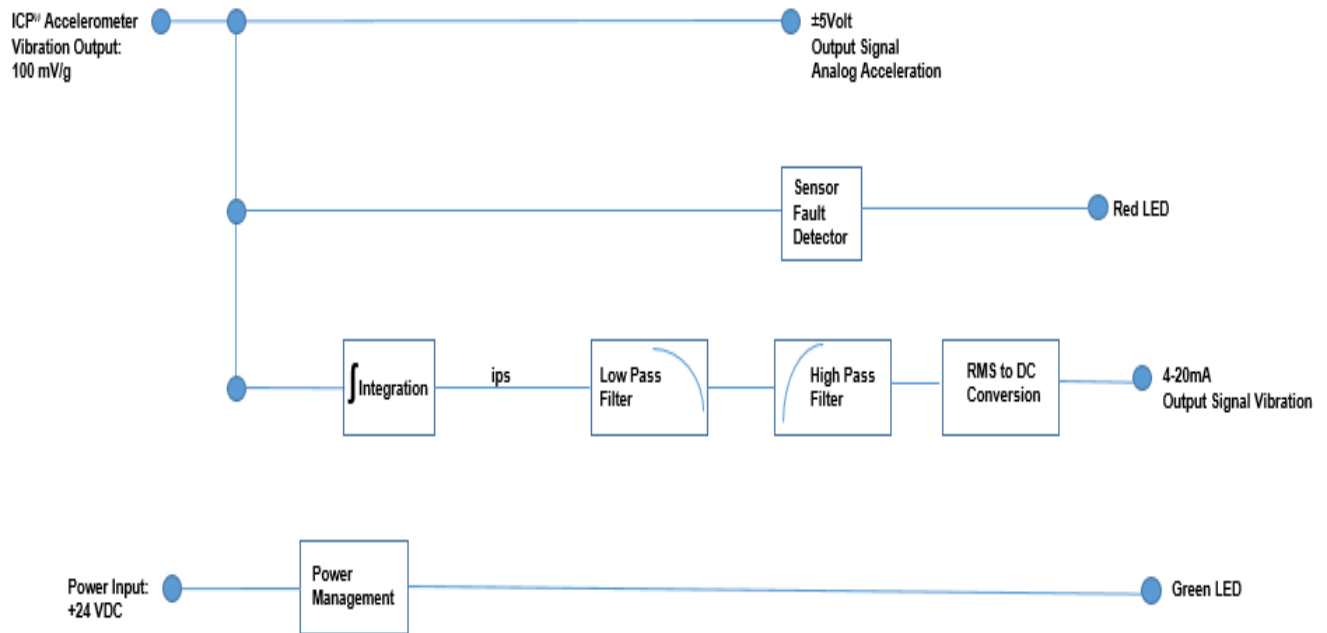

General Features

- External transmitters, signal conditioners and ICP® power supplies can be eliminated by direct connection of the sensor to the din rail signal conditioner.
- 24Vdc unregulated/20Vdc regulated (field-selectable), 4mA excitation to power sensor.
- Current (4-20mA) output signal for long-term process monitoring.
- Analog output (raw vibration) signal for conducting frequency analysis and machinery diagnostics.
- LED indicators for power and sensor fault.
- Removable terminal blocks for easy wiring.
- 35mm (1.38in) din rail mount configuration.
- Space-saving 22.5mm (0.9in.) wide design.

Installation and Wiring

Installation

Models 682A14 & 682A15 are designed to be mounted on a 35mm din rail. Do not install in a harsh area where it can be exposed to cleaning fluids or machine oils. IMI Sensors recommends mounting models 682A14 & 682A15 in a NEMA 4 enclosure, such as Model 682A00, to protect the electronics from contamination.

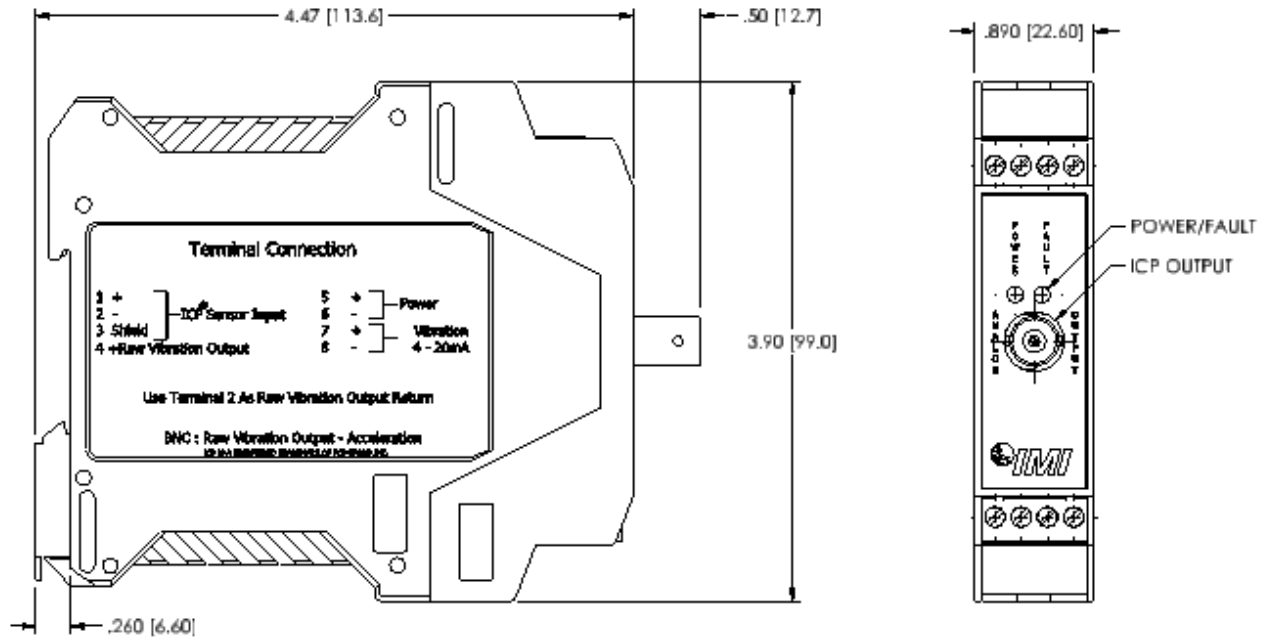

Dimension Drawing

Connector and Pinout Diagram

Models 682A14 & 682A15 use plug-in type screw terminal connectors for all input and output connections. This easy-to-assemble connection method allows devices to be exchanged easily and the electrical connection to be visibly isolated.

Strip off 8mm of insulation from the connection wire ends. Using a flat head screwdriver, remove the terminal block from the enclosure. Loosen the screw, insert the wire connection and tighten the screw. Do not exceed a torque of 0.5 N-m. Re-install the terminal block.

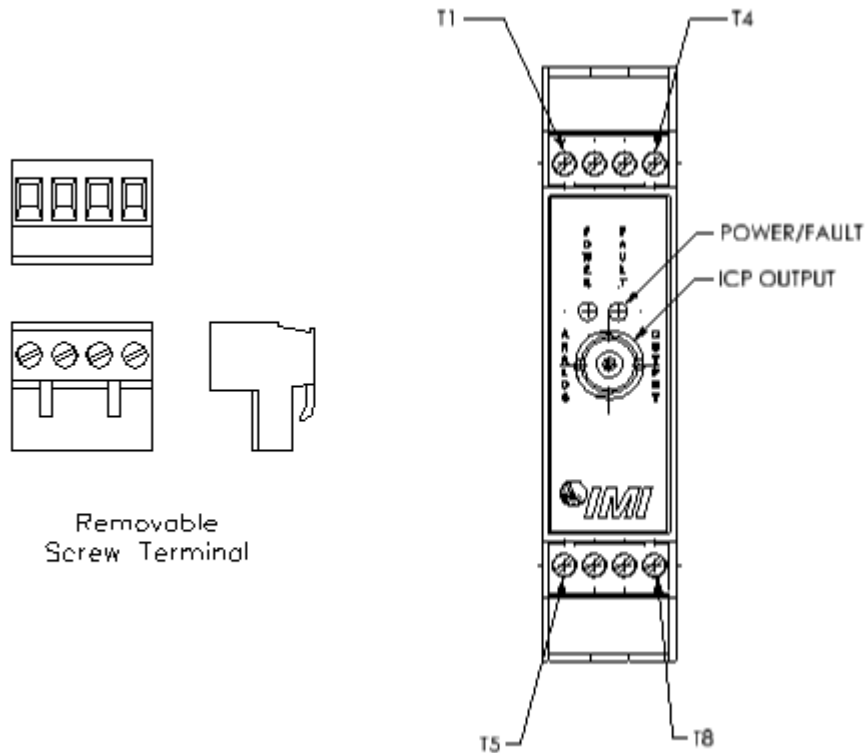

Pin Location Diagram



WARNING

**AC and DC input signals and power supply voltages could be hazardous.
DO NOT connect live wires to screw terminal plugs.
DO NOT insert, remove, or handle screw terminal plugs with live wires connected.**

Pin Descriptions:

DC Power – Pins 5 and 6:

- Pin 5** + Power
- Pin 6** - Power (Common)

ICP® Sensor Input – Pins 1, 2 and 3:

- Pin 1** + ICP® Sensor Input
- Pin 2** - ICP® Sensor Input
- Pin 3** Shield

Analog (Raw Vibration) Output – Pins 2 and 4 or BNC Jack:

- Pin 2** - Raw Vibration
- Pin 4** + Raw Vibration

Current (4 to 20mA) Output – Pins 7 and 8:

- Pin 7** + 4 to 20 mA Vibration
- Pin 8** - 4 to 20 mA Vibration

Notes:

- Pin 3 is tied to the grounding tab on the back of the enclosure.
- Land the accelerometer cable's shield on Pin 3.

Typical Wiring Diagram

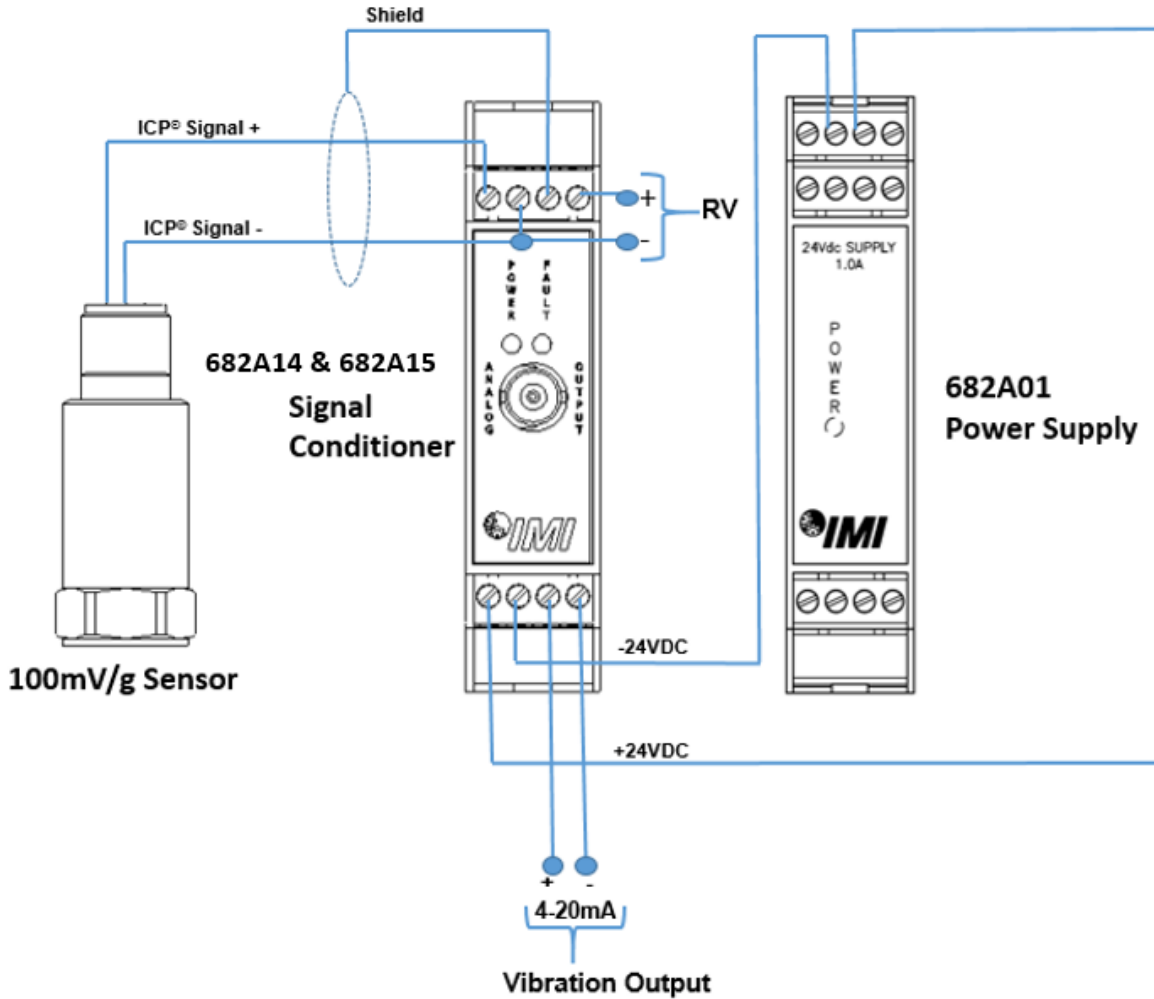

To maintain conformance, Earth Ground, power supply common, input shields and output shields must be connected together.

Configuring the 682A14 & 682A15

Sensor Power Jumper Configuration:

Regulated 20Vdc/4mA Power
(Factory Default)

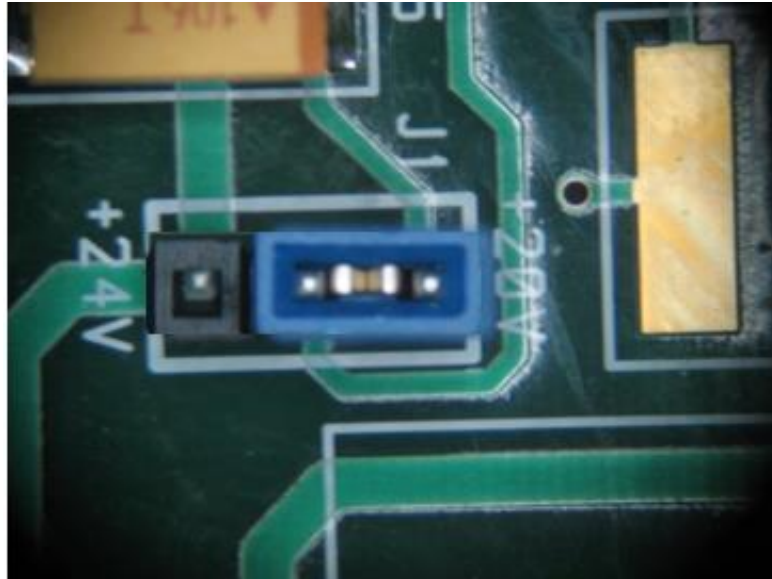

Unregulated 24Vdc/4mA Power
(Constant Current Diode is internal to Model 682A14 & 682A15.)

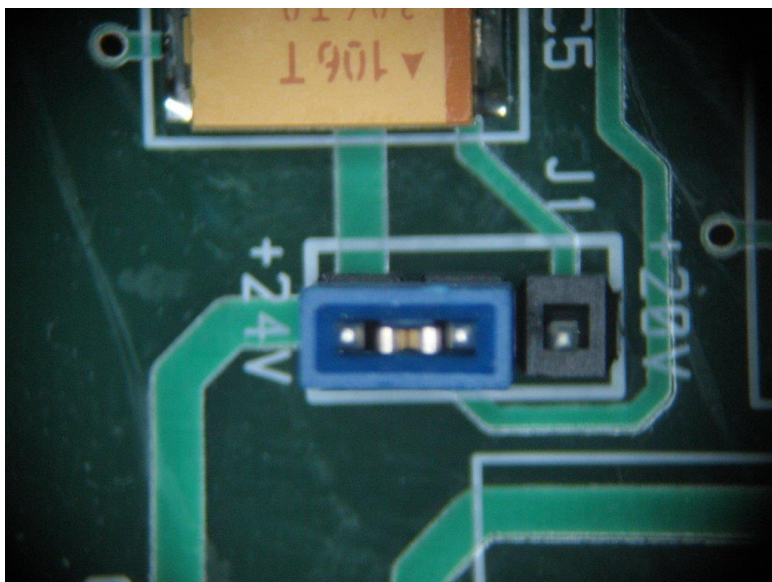

Warning 1 – ESD sensitivity

The power supply/signal conditioner should not be opened by anyone other than qualified service personnel. This product is intended for use by qualified personnel who recognize shock hazards and are familiar with the safety precautions required to avoid injury.

Warning 2 – ESD sensitivity

This equipment is designed with user safety in mind; however, the protection provided by the equipment may be impaired if the equipment is used in a manner not specified by PCB Piezotronics, Inc.

Caution 1 – ESD sensitivity

Cables can kill your equipment. High voltage electrostatic discharge (ESD) can damage electrical devices. Similar to a capacitor, a cable can hold a charge caused by triboelectric transfer, such as that which occurs in the following:

- *Laying on and moving across a rug,*
- *Any movement through air,*
- *The action of rolling out a cable, and/or*
- *Contact with a non-grounded person.*

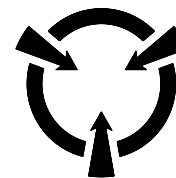

CAUTION
ELECTROSTATIC
DISCHARGE SENSITIVE

The PCB solution for product safety:

- *Connect the cables only with the AC power off.*
- *Temporarily “short” the end of the cable before attaching it to any signal input or output.*

Caution 2 – ESD sensitivity

ESD considerations should be made prior to performing any internal adjustments on the equipment. Any piece of electronic equipment is vulnerable to ESD when opened for adjustments. Internal adjustments should

therefore be done ONLY at an ESD-safe work area. Many products have ESD protection, but the level of protection may be exceeded by extremely high voltage.

Warranty

IMI instrumentation is warranted against defective material and workmanship for 1 year unless otherwise expressly specified. Damage to instruments caused by incorrect power or misapplication, is not covered by warranty. *If there are any questions regarding power, intended application, or general usage, please consult with your local sales contact or distributor.* Batteries and other expendable hardware items are not covered by warranty.

Service

Because of the sophisticated nature of IMI instrumentation, field repair is typically **NOT** recommended and may void any warranty. If factory service is required, return the instrumentation according to the "Return Procedure" stated below. *A repair and/or replacement quotation will be provided prior to servicing at no charge.* Before returning the unit, please consult a factory IMI applications engineer concerning the situation as certain problems can often be corrected with simple on-site procedures.

Return procedure

To expedite returned instrumentation, contact a factory IMI applications engineer for a RETURN MATERIAL AUTHORIZATION (RMA) NUMBER. Please have information available such as model and serial number. Also, to insure efficient service, *provide a written description of the symptoms and problems with the equipment to a local sales representative or distributor, or contact IMI if none are located in your area.*

Customers outside the U.S. should consult their local IMI distributor for information on returning equipment. For exceptions, please contact the International Sales department at IMI to request shipping instructions and an RMA. For assistance, please call (716) 684-0003, or fax us at (716) 684-3823. You may also receive assistance via e-mail at imi@pcb.com or visit our web site at www.pcb.com.



Customer Service

IMI, a division of PCB Piezotronics, guarantees **Total Customer Satisfaction**. If, at any time, for any reason, you are not completely satisfied with any IMI product, IMI will repair, replace, or exchange it at no charge. You may also choose, within the warranty period, to have your purchase price refunded.

IMI offers to all customers, at no charge, 24-hour phone support. This service makes product or application support available to our customers, day or night, seven days a week. When unforeseen problems or emergency situations arise, call the **IMI Hot Line at (716) 684-0003**, and an application specialist will assist you.



3425 Walden Avenue, Depew, NY 14043-2495
Phone: (716) 684-0003 • USA Fax: (716) 684-3823 • INTL Fax: (716) 684-4703

*ICP® is a registered trademark of PCB Group, Incorporated,
which uniquely identifies PCB sensors that incorporate built-in microelectronics.*