



Model 685B0001C14

**Electronic vibration switch, internal ICP® accel., 0-1.5 ips, AC powered, 10A form C relays,
Class 1 Div 1, groups B,C,D, dual 1/2" NPT ports**

Installation and Operating Manual

**For assistance with the operation of this product,
contact the PCB Piezotronics, Inc.**

**Toll-free: 800-959-4464
24-hour SensorLine: 716-684-0001
Fax: 716-684-3823
E-mail: imi@pcb.com
Web: www.imi-sensors.com**



Repair and Maintenance

PCB guarantees Total Customer Satisfaction through its “Lifetime Warranty Plus” on all Platinum Stock Products sold by PCB and through its limited warranties on all other PCB Stock, Standard and Special products. Due to the sophisticated nature of our sensors and associated instrumentation, **field servicing and repair is not recommended and, if attempted, will void the factory warranty.**

Beyond routine calibration and battery replacements where applicable, our products require no user maintenance. Clean electrical connectors, housings, and mounting surfaces with solutions and techniques that will not harm the material of construction. Observe caution when using liquids near devices that are not hermetically sealed. Such devices should only be wiped with a dampened cloth—never saturated or submerged.

In the event that equipment becomes damaged or ceases to operate, our Application Engineers are here to support your troubleshooting efforts 24 hours a day, 7 days a week. Call or email with model and serial number as well as a brief description of the problem.

Calibration

Routine calibration of sensors and associated instrumentation is necessary to maintain measurement accuracy. We recommend calibrating on an annual basis, after exposure to any extreme environmental influence, or prior to any critical test.

PCB Piezotronics is an ISO-9001 certified company whose calibration services are accredited by A2LA to ISO/IEC 17025, with full traceability to SI through N.I.S.T. In addition to our standard calibration services, we also offer specialized tests, including: sensitivity at elevated or cryogenic temperatures, phase response, extended high or low frequency response, extended range, leak testing, hydrostatic pressure testing, and others. For more information, contact your local PCB Piezotronics distributor, sales representative, or factory customer service representative.

Returning Equipment

If factory repair is required, our representatives will provide you with a Return Material Authorization (RMA) number, which we use to reference any information you have already provided and expedite the repair process. This number should be clearly marked on the outside of all returned package(s) and on any packing list(s) accompanying the shipment.

Contact Information

PCB Piezotronics, Inc.
3425 Walden Ave.
Depew, NY14043 USA
Toll-free: (800) 828-8840
24-hour SensorLine: (716) 684-0001
General inquiries: info@pcb.com
Repair inquiries: rma@pcb.com

For a complete list of distributors, global offices and sales representatives, visit our website, www.pcb.com.

Safety Considerations

This product is intended for use by qualified personnel who recognize shock hazards and are familiar with the precautions required to avoid injury. While our equipment is designed with user safety in mind, the protection provided by the equipment may be impaired if equipment is used in a manner not specified by this manual.

Discontinue use and contact our 24-Hour Sensorline if:

- Assistance is needed to safely operate equipment
- Damage is visible or suspected
- Equipment fails or malfunctions

For complete equipment ratings, refer to the enclosed specification sheet for your product.

Definition of Terms and Symbols

The following symbols may be used in this manual:



DANGER

Indicates an immediate hazardous situation, which, if not avoided, may result in death or serious injury.

**CAUTION**

Refers to hazards that could damage the instrument.

**NOTE**

Indicates tips, recommendations and important information. The notes simplify processes and contain additional information on particular operating steps.

The following symbols may be found on the equipment described in this manual:



This symbol on the unit indicates that high voltage may be present. Use standard safety precautions to avoid personal contact with this voltage.



This symbol on the unit indicates that the user should refer to the operating instructions located in the manual.



This symbol indicates safety, earth ground.



PCB工业监视和测量设备 - 中国RoHS2公布表

PCB Industrial Monitoring and Measuring Equipment - China RoHS 2 Disclosure Table

部件名称	有害物质					
	铅 (Pb)	汞 (Hg)	镉 (Cd)	六价铬 (Cr(VI))	多溴联苯 (PBB)	多溴二苯醚 (PBDE)
住房	0	0	0	0	0	0
PCB板	X	0	0	0	0	0
电气连接器	0	0	0	0	0	0
压电晶体	X	0	0	0	0	0
环氧	0	0	0	0	0	0
铁氟龙	0	0	0	0	0	0
电子	0	0	0	0	0	0
厚膜基板	0	0	X	0	0	0
电线	0	0	0	0	0	0
电缆	X	0	0	0	0	0
塑料	0	0	0	0	0	0
焊接	X	0	0	0	0	0
铜合金/黄铜	X	0	0	0	0	0
本表格依据 SJ/T 11364 的规定编制。						
0：表示该有害物质在该部件所有均质材料中的含量均在 GB/T 26572 规定的限量要求以下。						
X：表示该有害物质至少在该部件的某一均质材料中的含量超出 GB/T 26572 规定的限量要求。						
铅是欧洲RoHS指令2011/65/ EU附件三和附件四目前由于允许的豁免。						

CHINA RoHS COMPLIANCE

Component Name	Hazardous Substances					
	Lead (Pb)	Mercury (Hg)	Cadmium (Cd)	Chromium VI Compounds (Cr(VI))	Polybrominated Biphenyls (PBB)	Polybrominated Diphenyl Ethers (PBDE)
Housing	O	O	O	O	O	O
PCB Board	X	O	O	O	O	O
Electrical Connectors	O	O	O	O	O	O
Piezoelectric Crystals	X	O	O	O	O	O
Epoxy	O	O	O	O	O	O
Teflon	O	O	O	O	O	O
Electronics	O	O	O	O	O	O
Thick Film Substrate	O	O	X	O	O	O
Wires	O	O	O	O	O	O
Cables	X	O	O	O	O	O
Plastic	O	O	O	O	O	O
Solder	X	O	O	O	O	O
Copper Alloy/Brass	X	O	O	O	O	O

This table is prepared in accordance with the provisions of SJ/T 11364.

O: Indicates that said hazardous substance contained in all of the homogeneous materials for this part is below the limit requirement of GB/T 26572.

X: Indicates that said hazardous substance contained in at least one of the homogeneous materials for this part is above the limit requirement of GB/T 26572.

Lead is present due to allowed exemption in Annex III or Annex IV of the European RoHS Directive 2011/65/EU.

685B-Series Electronic Vibration Switch

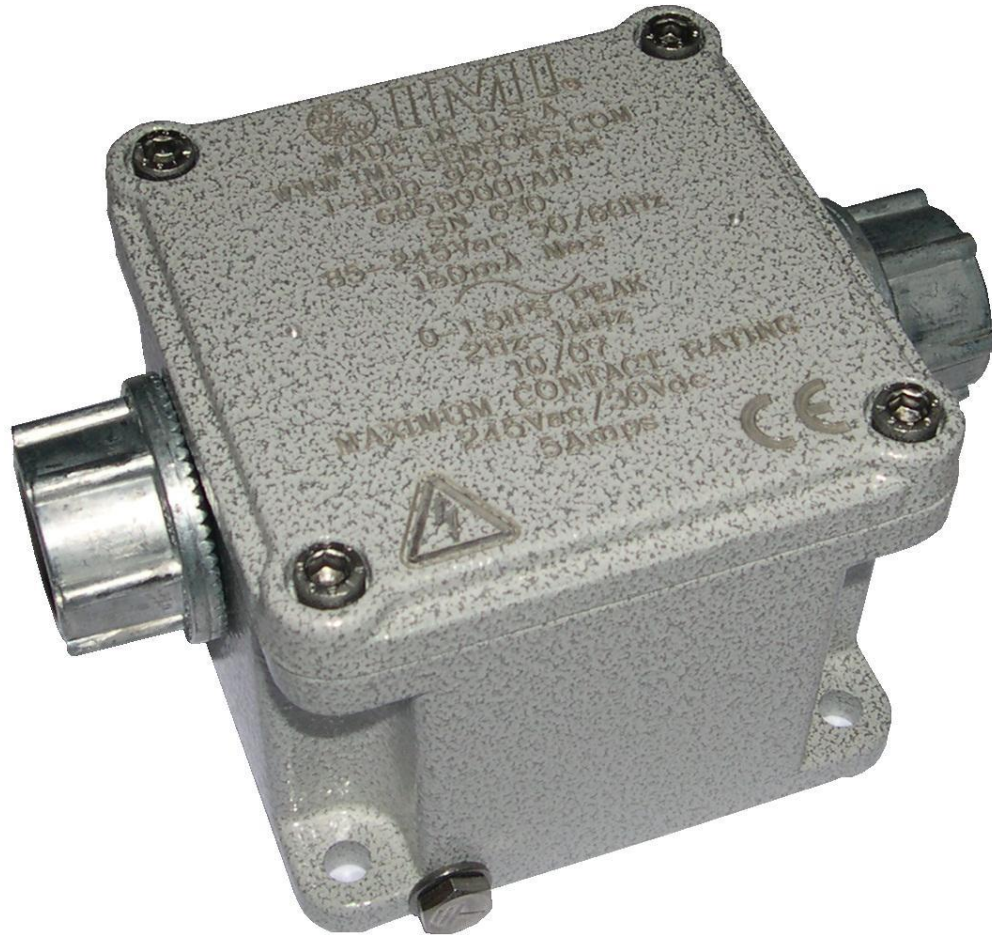

Operating Guide with Enclosed Warranty Information

3425 Walden Avenue, Depew, New York 14043-2495

Phone (716) 684-0003

Fax (716) 684-3823

Toll Free Line 1-800-959-4IMI

MANUAL NUMBER: 34181
MANUAL REVISION: **H**
ECO# **47640**

Table of Contents

Introduction.....	Page 3
General Features	
Specifications	Page 4
Installation and Wiring	Page 5
Installation & Dimensional Drawings	
Pin Location Diagram- Models with Internal Accelerometer and Triac Relays	
Pin Location Diagram- Models with Internal Accelerometer and Electromechanical Relays	
Pin Location Diagram- Models with External Accelerometer and Triac Relays	
Pin Location Diagram- Models with External Accelerometer and Electromechanical Relays	
Configuring the 685B.....	Page 11
Internal Diagram- Models with Triac Relays	
Internal Diagram- Models with Electromechanical Relays	
Using Calibration Mode	
Connecting the Remote Reset	
Connecting the Raw Vibration Output	
Optional Accessories.....	Page 14
080A209 Adapter Plate	
699A05 Portable 4-20 mA Calibrator	
ESD Sensitivity.....	Page 16
Ordering Information/ Model Matrix	Page 17

Introduction

The 685B-Series is an electronic vibration switch designed to monitor vibration levels and trip an alert when a specified limit is exceeded. A second onboard relay trips an alarm that can be used to shut down a piece of equipment or act as a secondary alert level. An onboard accelerometer with precision electronics insures reliability and accuracy.

General Features

- Embedded or external piezoelectric accelerometer for improved accuracy and frequency response.
- Vibration range can be measured in acceleration, velocity or displacement (factory set).
- Provides dual 5 Amp Triac (SPST) or 10 Amp Form C (SPDT) relay outputs.
- Adjustable trip limits and time delay via single turn potentiometers.
- Accommodates normally open (NO) and normally closed (NC) wiring schemes.
- Continuous or latching switch action.
- Local reset button and remote reset capability.
- LED indicators for power, alert and alarm.
- Screw terminal blocks for easy wiring.
- Mounts directly to the equipment being monitored via four bolt pattern.
- Flexible design allows for various custom requirements.
- 4-20 mA field calibration feature for improved accuracy.
- Raw vibration & 4-20 mA outputs as standard.

Specifications

- **Power Supply Voltage:** 85-240 VAC, 12-30 VDC (factory set)
- **Power Supply Current:** 150 mA max
- **Sensor Type:** Piezoelectric Sensing Element
- **Standard Vibration Ranges:** 0-5g pk, 0-1.5 ips pk, 0-3 ips pk, 0-50 mils pk-pk, 0-15 mils pk-pk (factory set)
- **Frequency Response +/-3dB:** 2Hz to 1Khz (120 – 60,000cpm)
- **Turn on Time Delay:** 20 seconds
- **Alert/Alarm Time Delay:** 0-45 seconds
- **Alert/Alarm Function Select:** Latch or Continuous
- **Alert/Alarm Switches:** 5A/245Vac Triac (SPST) or 10A/245Vac – 5A/30Vdc Form C Relay (SPDT)
- **Operating Temperature Range:** -22 to 158°F (-30 to 70°C)
- **Storage Temperature Range:** -40 to 257°F (-40 to 125°C)
- **Relative Humidity:**..... NEMA 4X Rating
- **Case Dimension W x H x D:** 3.5 x 2.8 x 3.5in. (90 x 70 x 90mm)
- **Weight:** 1.85 lbs. (839 grams)
- **Case Material:** Aluminum Alloy
- **Input/Output Electrical Connectors:** Screw Terminals
- **Screw Terminal Wire Size:** 24-14 AWG (0.2-2.5 mm²)
- **Wiring Interface:** Cord Grips (wire comp. dia. 0.2”- 0.35”) or ½” NPT Conduit Hubs
- **Mounting Hole Size:** 0.21 inches
- **Mounting Screw Torque:** 2- 5 ft. lbs. (3-7Nm)
- **LED Indicators:**
 - Power: - Green
 - Alarm: - Red
 - Alert: - Yellow
- **Alert/ Alarm Setpoint:** Single Turn Potentiometer (10-100% Full Scale Range)
- **Reset Function:** Momentary Pushbutton Switch and/or Remote to Common.

Installation and Wiring

Installation

The 685B-Series is designed to be mounted directly on the equipment to be monitored using a four-bolt pattern. There are also options to retrofit existing 3 bolt pattern installations. (Model 080A209 mounting plate required- see optional accessories on page 13). Use grease between all surfaces to insure specified frequency response, otherwise performance will be degraded. The axis of vibration measured by models with internal accelerometers is perpendicular to the mounting orientation of the unit.

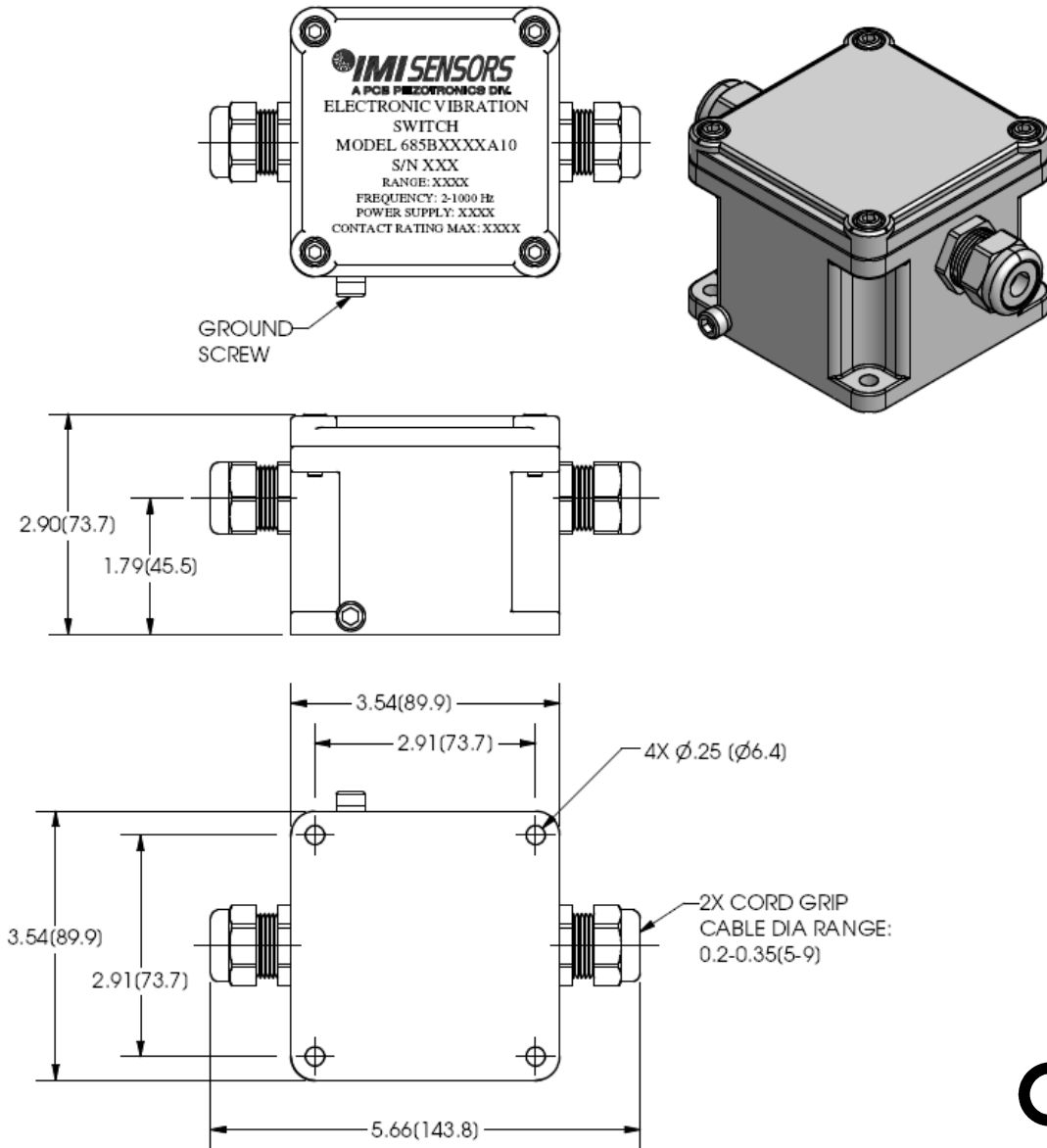

Standard Model Dimension Drawing with Cord Grips

Inch (mm)



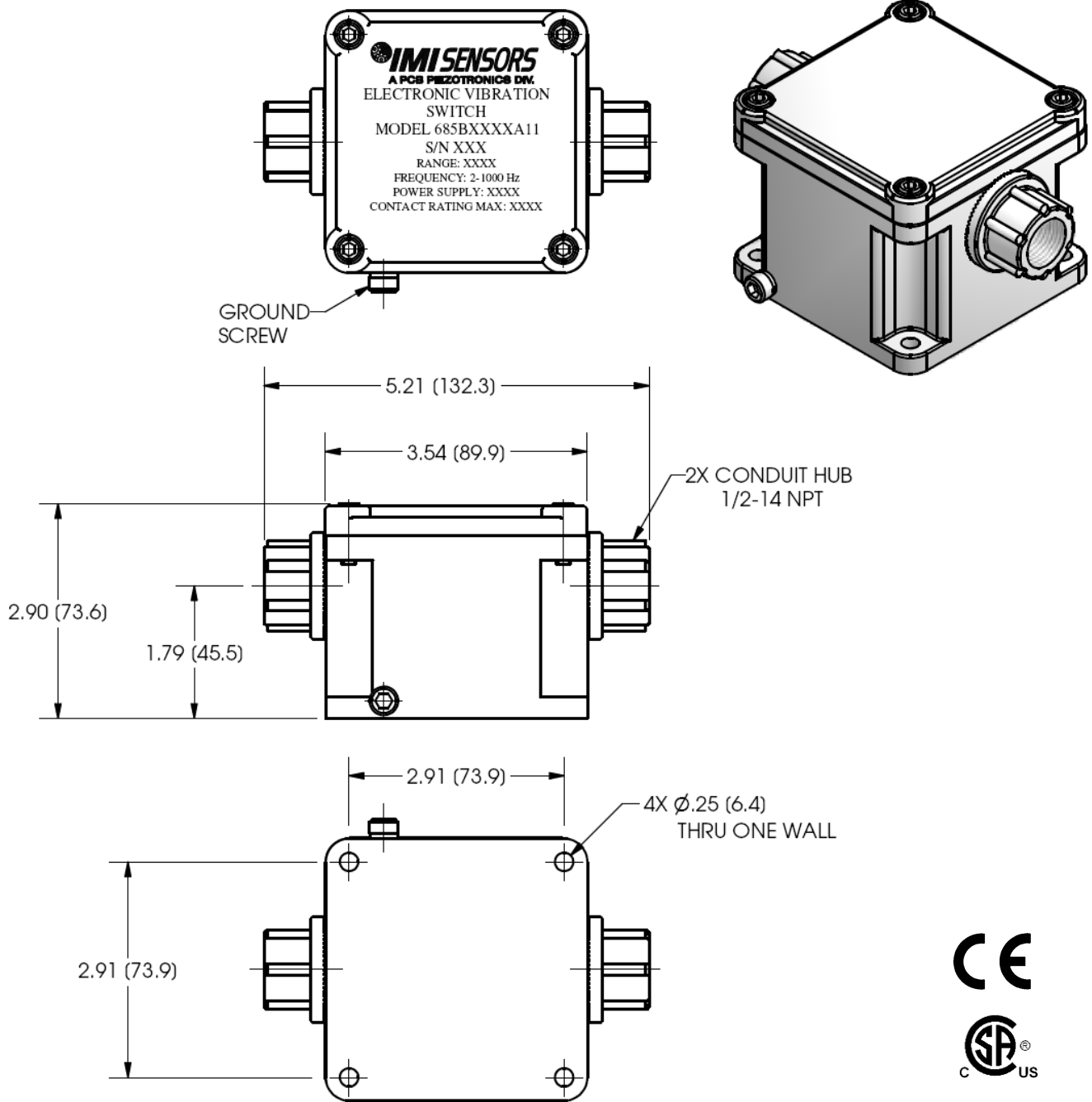

Standard Model Dimension Drawing with 1/2" NPT Conduit Hubs
Inch (mm)

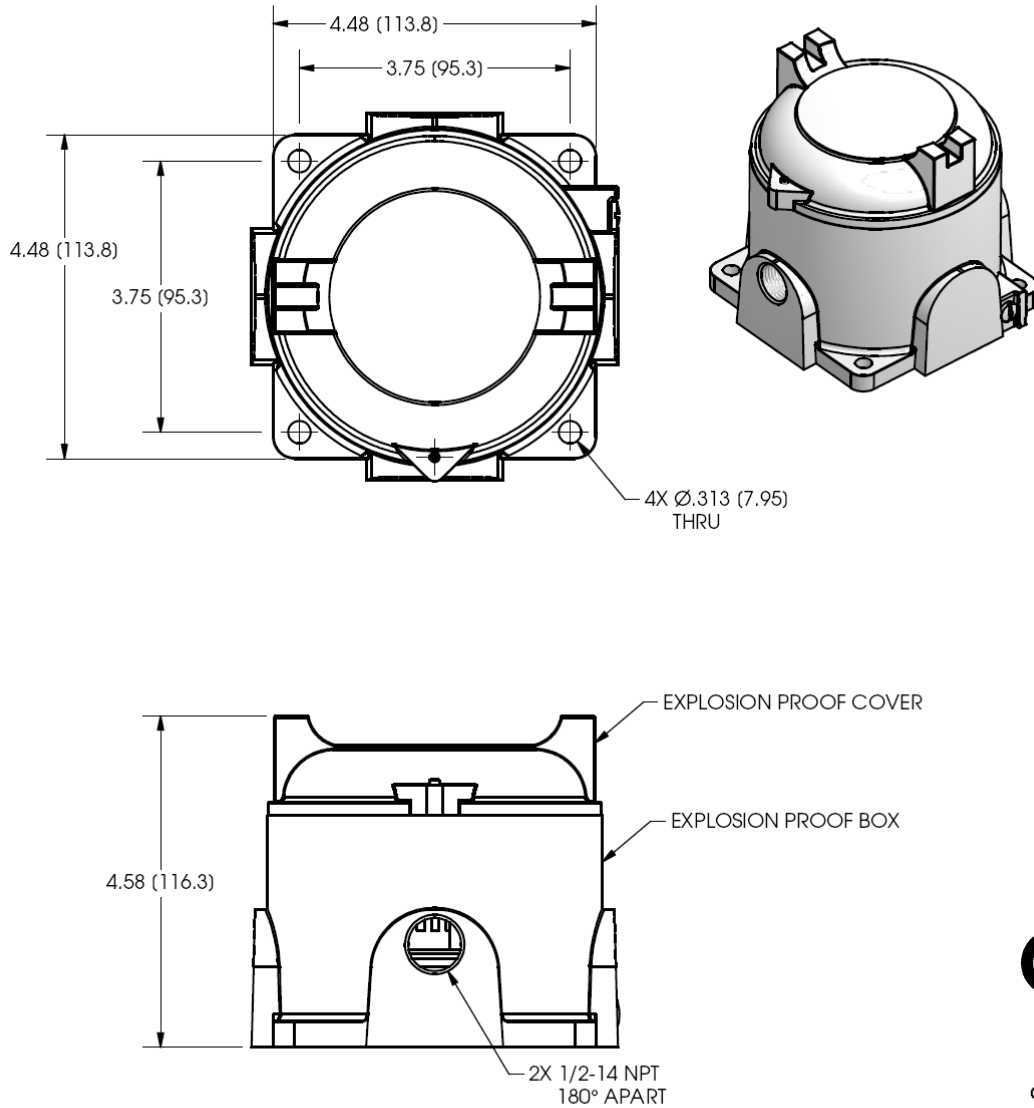

Explosion Proof Model Dimension Drawing
Inch (mm)



WARNING

AC and DC input signals and power supply voltages could be hazardous. DO NOT connect live wires to screw terminal plugs, and DO NOT insert, remove, or handle screw terminal plugs with live wires connected.

Connector and Pinout Diagram

The 685B-Series uses screw terminal connectors for all input and output connections.

Strip off 0.3" (8mm) of insulation from the connection wire ends. Feed the wire through the access ports, and terminate the wire in the correct location. Once connected, tug lightly on the wire to confirm connection is secure.

Pin Location Diagram- Models with Internal Accelerometer and Triac Relays

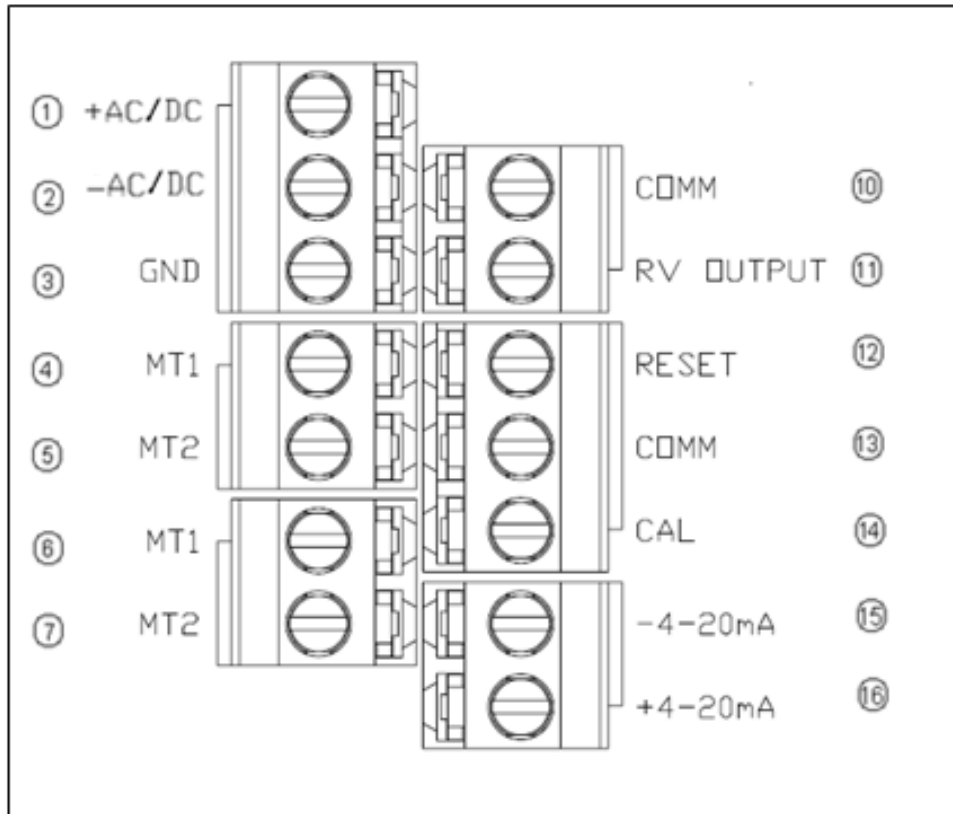

Pin	Category	Description
1	AC Power	+ Power
2		- Power/Common
3		Earth Ground (Also connect to enclosure safety lug)
4	Alarm Output	Main Terminal 1
5		Main Terminal 2
6	Alert Output	Main Terminal 1
7		Main Terminal 2
8	N/A	N/A
9		N/A
10	Raw Vibration Output	Common
11		+Signal
12	Control Configurations	Remote Reset Connection (Do not apply power)
13		Common Connection
14		Calibration Connection
15	Current Output	- 4-20 mA
16		+ 4-20 mA

Pin Location Diagram- Models with Internal Accelerometer and Electromechanical Relays

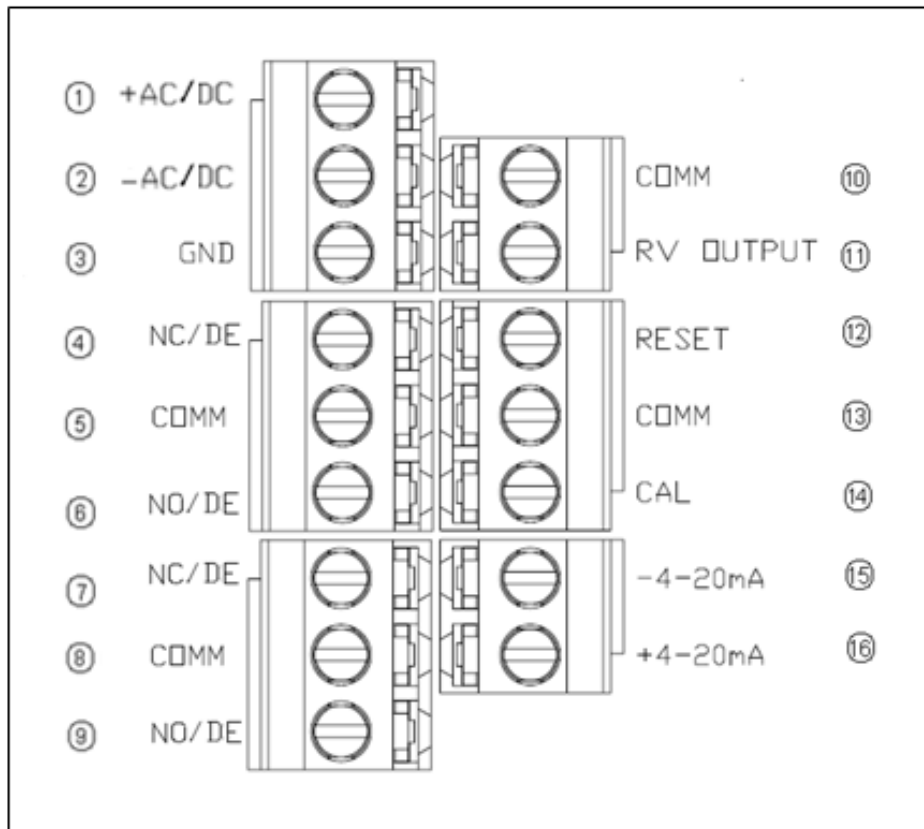

Pin	Category	Description
1	AC Power	+ Power
2		- Power/Common
3		Earth Ground (Also connect to enclosure safety lug)
4	Alarm Output	Normally Closed (when dipswitch is in de-energized position)
5		Common connection
6		Normally Open (when dipswitch is in de-energized position)
7	Alert Output	Normally Closed (when dipswitch is in de-energized position)
8		Common connection
9		Normally Open (when dipswitch is in de-energized position)
10	Raw Vibration Output	Common
11		+Signal
12	Control Configurations	Remote Reset Connection (Do not apply power)
13		Common Connection
14		Calibration Connection
15	Current Output	- 4-20 mA
16		+ 4-20 mA

Pin Location Diagram- Models with External Accelerometer and Triac Relays

When the external 100mV/g ICP® sensor option is specified, an additional terminal block location is added to the 685B-Series. The external accelerometer is connected to +Sensor and –Sensor positions as indicated in the above figure and on the product label locate inside the top cover. The cable shield to the accelerometer should be grounded as required by local codes as well as to limit RFI/EMI interference.

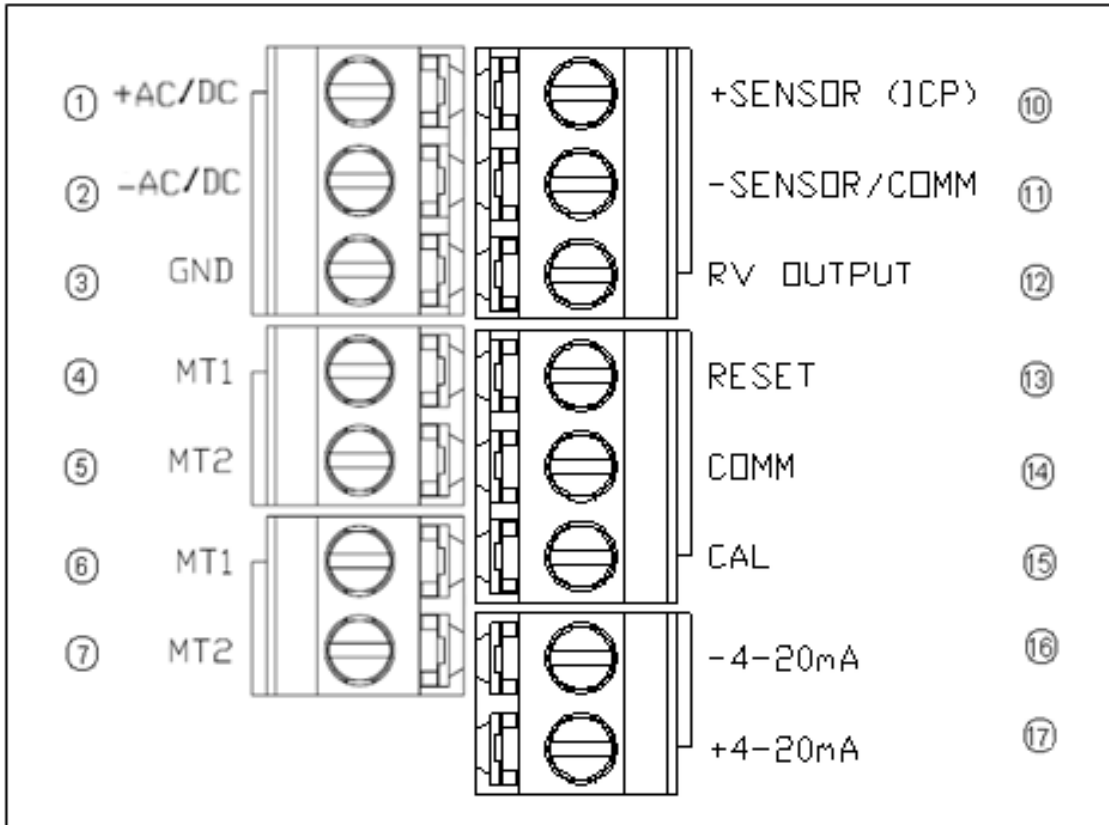

Pin	Category	Description
1	AC Power	+ Power
2		- Power/Common
3		Earth Ground (Also connect to enclosure safety lug)
4	Alarm Output	Main Terminal 1
5		Main Terminal 2
6	Alert Output	Main Terminal 1
7		Main Terminal 2
8	N/A	N/A
9		N/A
10	Sensor Input & Raw Vibration Output	+ Sensor
11		- Sensor/Common
12		+Signal
13	Control Configurations	Remote Reset Connection (Do not apply power)
14		Common Connection
15		Calibration Connection
16	Current Output	- 4-20 mA
17		+ 4-20 mA

Pin Location Diagram- Models with External Accelerometer and Electromechanical Relays

When the external 100mV/g ICP® Sensor option is specified, an additional terminal block location is added to the 685B-Series. The external accelerometer is connected to +Sensor and –Sensor positions as indicated in the above figure and on the product label locate inside the top cover. The cable shield to the accelerometer should be grounded as required by local codes as well as to limit RFI/EMI interference.

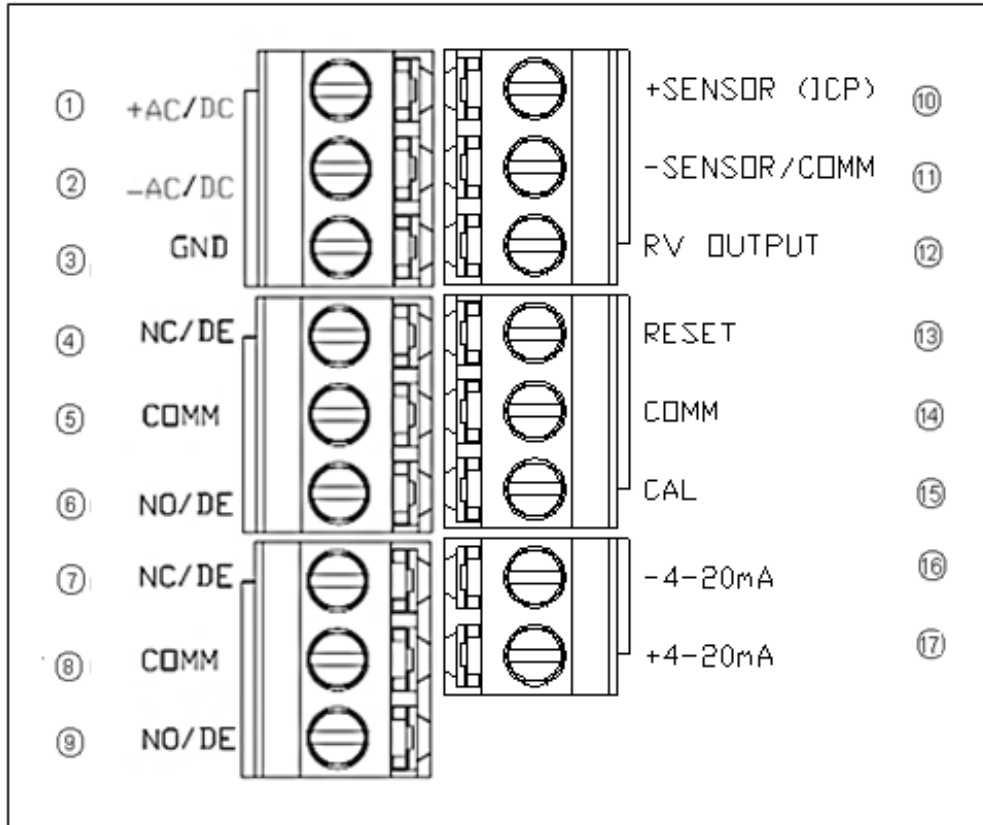

Pin	Category	Description
1	AC Power	+ Power
2		- Power/Common
3		Earth Ground (Also connect to enclosure safety lug)
4	Alarm Output	Normally Closed (when dipswitch is in de-energized position)
5		Common connection
6		Normally Open (when dipswitch is in de-energized position)
7	Alert Output	Normally Closed (when dipswitch is in de-energized position)
8		Common connection
9		Normally Open (when dipswitch is in de-energized position)
10	Sensor Input & Raw Vibration Output	+ Sensor
11		- Sensor/Common
12		+Signal
13	Control Configurations	Remote Reset Connection (Do not apply power)
14		Common Connection
15		Calibration Connection
16	Current Output	- 4-20 mA
17		+ 4-20 mA

Configuring the 685B-Series

Internal Diagram- Models with Triac Relays

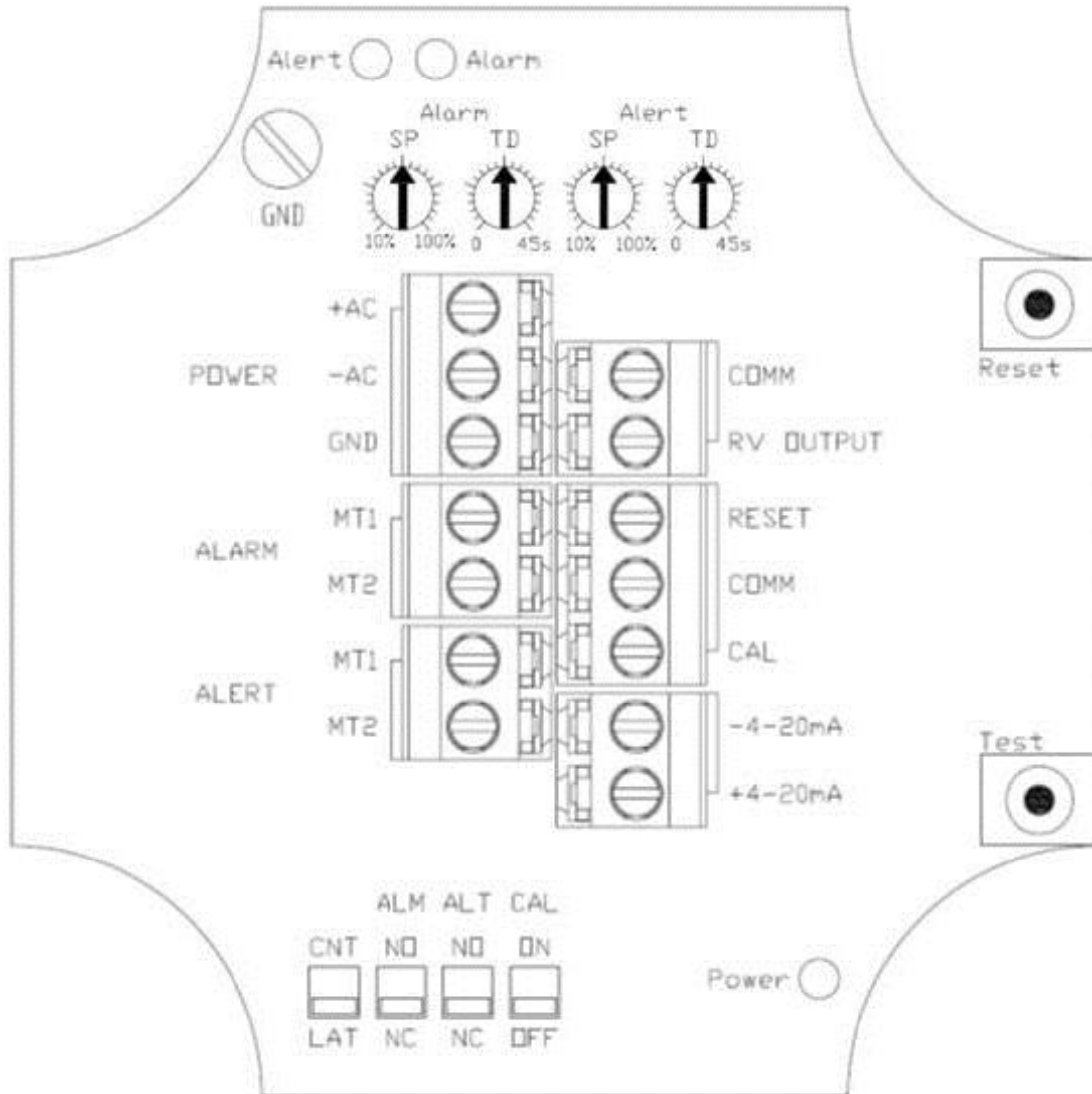

The internal diagram displays the location of the control features for the triac versions of the 685B-Series. The alert and alarm set points are adjusted via the single turn potentiometers. The alarm relay is set using the first potentiometer, and the alert relay is set using the third. The alert relay trips when the set percentage of the alarm value is reached. Time delays for both functions are controlled using the second and fourth potentiometers. Alert and alarm relays can be reset remotely by using the RESET and COMM pins or by using the internal reset switch as seen on the upper right hand corner of the diagram.

Using the dipswitches beneath the terminal connectors, relay operation can be selected to be either latch or continuous, and each relay can be separately configured to be normally open (de-energized) or normally closed (energized). There is also a dipswitch to activate the **calibration mode** for condition simulation during the setup process. This is explained in detail on page 13.

Internal Diagram- Models with Electromechanical Relays

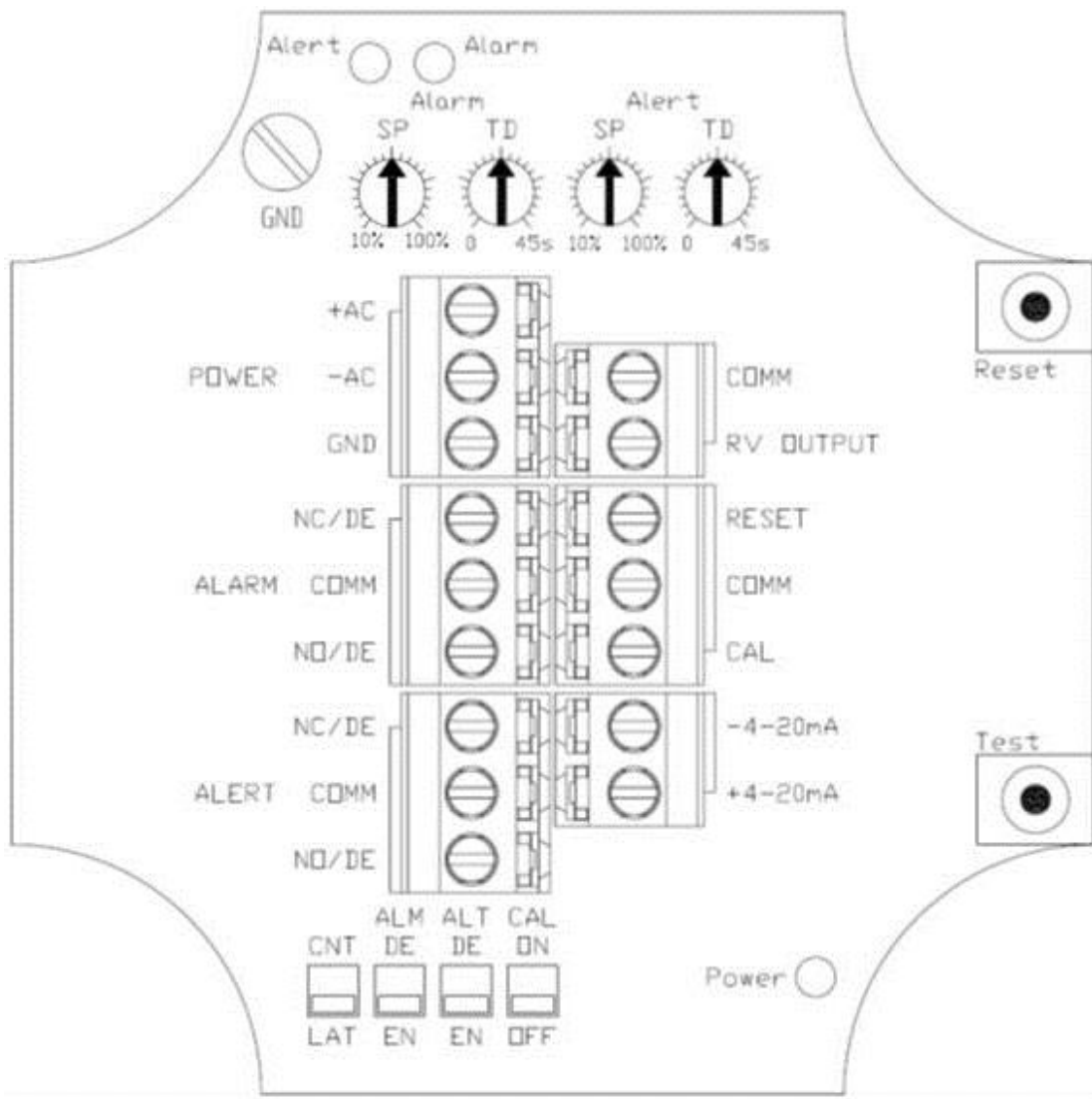

The internal diagram displays the location of the control features for the relay versions of the 685B-Series. The alert and alarm set points are adjusted via the single turn potentiometers. The alarm relay is set using the first potentiometer, and the alert relay is set using the third. The alert relay trips when the set percentage of the alarm value is reached. Time delays for both functions are controlled using the second and fourth potentiometers. Alert and alarm relays can be reset remotely by using the RESET and COMM pins or by using the internal reset switch as seen on the upper right hand corner of the diagram.

Using the first dipswitch beneath the terminal connectors, relay operation can be selected to be either latch or continuous. The second and third dipswitches set the alert and alarm relay configuration to be energized or de-energized. The diagram above indicates the contacts that are normally open and normally closed when the dip switch is set to “de-energized”. When the dipswitch is changed to “energized”, the normally open and normally closed contacts would be reversed. The fourth dipswitch is used to activate the **calibration mode** for condition simulation during the setup process. This is explained in detail on page 12.

Using Calibration Mode

The 685B-Series has the unique ability to be calibrated using a 4-20 mA simulator. (IMI Sensors model 699A05, see “Accessories” page) This allows for a much more accurate and quantifiable calibration versus manually attuning the switch. The following steps allow for simple calibration using this configuration.

- 1) Connect the 4-20 mA simulator signal across the COMM and CAL pins.
- 2) Turn the calibration dipswitch to “on”. This will disable the switch’s ability to measure physical vibration.
- 3) Turn both time delay potentiometers to “zero” for calibration purposes. This can be adjusted to desired delay after calibration.
- 4) Assume that 4 mA equals zero vibration and 20 mA equals full scale vibration. Then calculate, in mA, the vibration level for which the alert and alarm switches should trip.
- 5) Using the 4-20 mA simulator, send the appropriate alarm signal based on the calculation in the previous step for the alarm signal.
- 6) Adjust the “SP” Alarm set point potentiometer to the point when the red Alarm LED illuminates.
- 7) Using the 4-20 mA simulator, repeat step 5 for the Alert signal.
- 8) Adjust the “SP” Alert set point potentiometer to the point where the yellow Alert LED illuminates. It is important to set the Alarm potentiometer first because the Alert signal acts as a percentage of the value set for Alarm.
- 9) Disconnect the 4-20 mA simulator.
- 10) Turn “off” the calibration dipswitch.

**** Warning: To avoid damage, insure 685B-Series is under power prior to applying the 4-20mA signal from the simulator. ****

Testing the Calibration

Pushing the “Test” button inside the housing simulates full scale vibration and should illuminate both the alert and alarm LED’s. This feature can be used to adjust time delays to the desired values. This can be accurately calculated using the “Test” button and a stopwatch.

Connecting the Remote Reset

The 685B-Series allows for remote reset when the switch is in latch mode via a short between the RESET and COMM pins.

Connecting the Raw Vibration Output

All models in the 685B-Series offer the option for obtaining accelerometer’s raw vibration signal. Models with internal accelerometers output 100 mV/g. To obtain this signal using digital analyzer, turn the ICP® power **OFF** at the digital analyzer input. Connect the analyzer to the RV OUTPUT and COMM pins with the common connection on the COMM pin and the signal connection on the RV OUTPUT pin.

Optional Accessories

Model 080A209 Adapter Plate

To retrofit old style vibration switch bolt patterns

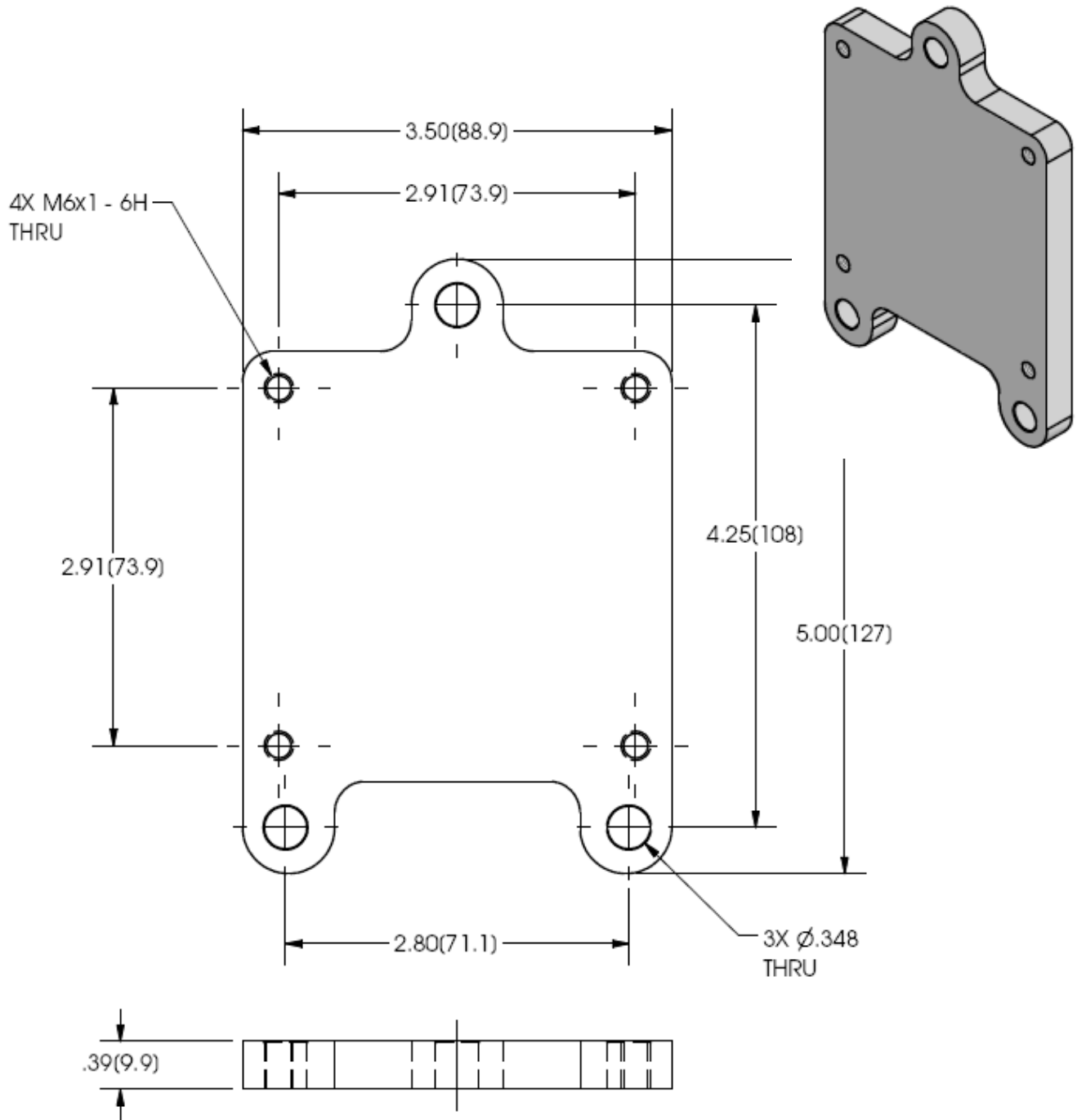

Model 699A05 Portable 4-20 mA Calibrator

Provides current output for 685B-Series testing, read-out and calibration purposes. Also receives and displays current signal from 4-20 mA proportional output from the 685B-Series.

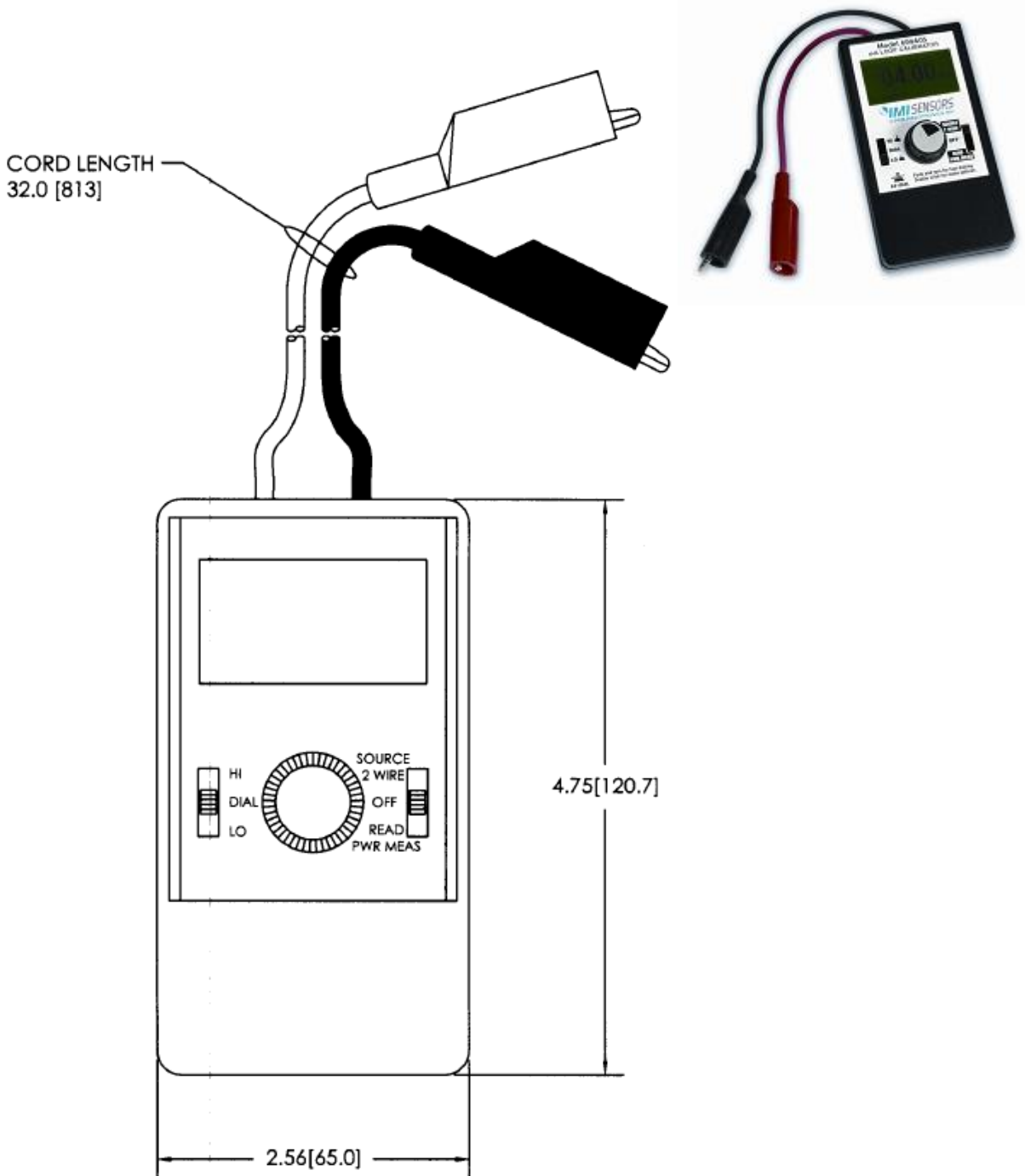

Warning 1 – ESD sensitivity

The power supply/signal conditioner should not be opened by anyone other than qualified service personnel. This product is intended for use by qualified personnel who recognize shock hazards and are familiar with the safety precautions required to avoid injury.

Warning 2 – ESD sensitivity

This equipment is designed with user safety in mind; however, the protection provided by the equipment may be impaired if the equipment is used in a manner not specified by PCB Piezotronics, Inc.

Caution 1 – ESD sensitivity

Cables can kill your equipment. High voltage electrostatic discharge (ESD) can damage electrical devices. Similar to a capacitor, a cable can hold a charge caused by triboelectric transfer, such as that which occurs in the following:

- *Laying on and moving across a rug,*
- *Any movement through air,*
- *The action of rolling out a cable, and/or*
- *Contact with a non-grounded person.*

The PCB solution for product safety:

- *Connect the cables only with the AC power off.*
- *Temporarily “short” the end of the cable before attaching it to any signal input or output.*

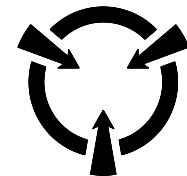

CAUTION
ELECTROSTATIC
DISCHARGE SENSITIVE

Caution 2 – ESD sensitivity

ESD considerations should be made prior to performing any internal adjustments on the equipment. Any piece of electronic equipment is vulnerable to ESD when opened for adjustments. Internal adjustments should therefore be done ONLY at an ESD-safe work area. Many products have ESD protection, but the level of protection may be exceeded by extremely high voltage.

Ordering Information/ Model Matrix

IMI Part Number: **685B** 0 0 0 0 **A1** 0

Basic Model Series _____

685B

Sensor Option _____

- 0 *Internal 100 mV/g ICP Sensor*
- 1 External 100mV/g ICP® Sensor
- 2 External 100 mV/g ICP Sensor (Low Frequency)
- 3 *Internal 100 mV/g ICP Sensor (Low Frequency)*
- 4 External 100mV/g ICP® Sensor (Sensor Fault Detection)
- 5 External 100mV/g ICP® Sensor (Sensor Fault Detection)

Scale Factor _____

- 0 *0-1.5 in/sec peak*
- 1 *0-5 g peak*
- 2 *0-15 mils peak to peak displacement*
- 3 *0-50 mils peak to peak displacement*
- 4 *0-3.0 in/sec peak*

Power Required _____

- 0 *85-245 VAC, 50/60 Hz*
- 1 *24 VDC ±10%*

Relay Type (two provided) _____

- 0 *Triac, 5A/245vac*
- 1 *Form C Relay (SPDT) 10A/245Vac – 5A/30Vdc*

Enclosure Type/ Hazardous Area Approval _____

- A1 *Basic enclosure, internal pushbutton for remote reset*
- A2 Same as A1, plus external pushbutton for remote reset
- A3 Same as A1, plus acceleration signal through external BNC
- A4 Same as A1, plus A2 & A3
- C1 Explosion Proof Enclosure (must select option 4 connection)

Connection Interface _____

- 0 Dual openings, cord grips
- 1 *Dual openings, ½" NPT conduit hubs*
- 2 Single opening, cord grip
- 3 *Single opening, ½" NPT conduit hub*
- 4 Dual openings, ½" NPT conduit hubs (for C1 enclosures only)
- 5 Dual openings, cord grip on left, ½" NPT conduit hub on right
- 6 Dual openings, cord grip on right, ½" NPT conduit hub on left

CSA Class I, Division 2 approval is supplied as standard for switches that are NOT using the C1 enclosure but are using all italicized options.

Model Number
685B0X01C14

ELECTRONIC VIBRATION SWITCH

Revision: C
ECN #: 53981

Performance	ENGLISH	SI	
Measurement Range	0 to 5 g pk	0 to 49 m/s ² pk	[1]
Measurement Range	0 to 15 mil pk - pk	0 to 381 μm pk - pk	[2]
Measurement Range	0 to 50 mil pk - pk	0 to 1.27 mm pk - pk	[3]
Measurement Range	0 to 3.0 in/sec pk	0 to 76.2 mm pk - pk	[4]
Measurement Range	0 to 1.5 in/sec pk	0 to 38.1 mm/s pk	[5]
Frequency Range(± 3 dB)	120 to 60,000 cpm	2 to 1,000 Hz	[6]
Power On Delay	20 sec	20 sec	[7]
Relay(Alert)	10A/245 VAC or 5A/30 VDC	10A/245 VAC or 5A/30 VDC	
Relay(Alarm)	10A/245 VAC or 5A/30 VDC	10A/245 VAC or 5A/30 VDC	
Relay(Contacts)	Latching / Non-Latching	Latching / Non-Latching	
Relay(Contacts)	Normally Open / Closed	Normally Open / Closed	
Alarm Setpoint	10 to 100% of Vibration Range	10 to 100% of Vibration Range	
Alert Setpoint	10 to 100% of Alarm Setpoint	10 to 100% of Alarm Setpoint	
Delay(Alert)	0 to 45 sec	0 to 45 sec	
Delay(Alarm)	0 to 45 sec	0 to 45 sec	
Acceleration Output(± 10%)	100 mV/g	10.2 mV/(m/s ²)	
Control Interface			
Power LED	Green	Green	
Alarm LED	Red	Red	
Alert LED	Yellow	Yellow	
Set Point Adjustment	Single Turn Potentiometer	Single Turn Potentiometer	
Time Delay Adjustment	Single Turn Potentiometer	Single Turn Potentiometer	
Reset Function	Momentary Pushbutton Switch	Momentary Pushbutton Switch	[8]
Self Test Function	Momentary Pushbutton Switch	Momentary Pushbutton Switch	
Switch Mechanism Function Select	NO/NC	NO/NC	
Alarm/Alert Function Select	Latch or Continuous	Latch or Continuous	
Environmental			
Temperature Range(Operating)	-13 to 158 °F	-25 to 70 °C	
Temperature Range(Storage)	-40 to 257 °F	-40 to 125 °C	
Hazardous Area Approval	Class I Div 1 Groups B, C, D	Class I Div 1 Groups B, C, D	
Hazardous Area Approval	Class II Div 1 Groups E, F, G	Class II Div 1 Groups E, F, G	
Hazardous Area Approval	Class III	Class III	
Hazardous Area Approval	Ex d IIB+H2 T4	Ex d IIB+H2 T4	
Enclosure Rating	NEMA 4	IP66	
Electrical			
Power Required	85-245 VAC 50/60 Hz <150mA	85-245 VAC 50/60 Hz <150mA	
Current Consumption	< 150 mA	< 150 mA	
Output Current	4 to 20 mA	4 to 20 mA	[9]
External Calibration Input	4 to 20 mA	4 to 20 mA	[10]
Raw Vibration Output(±20%)	100 mV/g	100 mV/g	
Physical			
Size (Width x Height x Depth)	4.48 in x 4.58 in x 4.48 in	114 mm x 116 mm x 114 mm	
Weight	4 lb	1.8 kg	
Mounting Torque(Base)	2 to 5 ft-lb	3 to 7 Nm	
Sensing Element(Internal)	100 mV/g ICP® Accelerometer	100 mV/g ICP® Accelerometer	
Housing Material	Aluminum Alloy	Aluminum Alloy	
Electrical Connector	Screw Terminals	Screw Terminals	
Enclosure	Internal and Remote Reset	Internal and Remote Reset	
Screw Terminal Wire Size	24-14 AWG	0.2 - 2.5 mm ²	
Cable Input	1/2" -14 threaded NPT Female	1/2" -14 threaded NPT Female	
Mounting Hole Size	0.31 in	7.8 mm	

OPTIONAL VERSIONS

Optional versions have identical specifications and accessories as listed for the standard model except where noted below. More than one option may be used.

NOTES:

- [1] Measurement Range for 685B0101C14.
- [2] Measurement Range for 685B0201C14.
- [3] Measurement Range for 685B0301C14.
- [4] Measurement Range for 685B0401C14.
- [5] Measurement Range for 685B0001C14.
- [6] To obtain 60000 cpm (1000 Hz) frequency response, grease must be applied to all mechanical couplings. Otherwise, frequency response is limited to approximately 30000 cpm (500 Hz)
- [7] Factory Set
- [8] Reset can also be engaged via external connection to common
- [9] Current will fluctuate at frequencies below 5 Hz.
- [10] Active only during calibration mode
- [11] See PCB Declaration of Conformance PS051 for details.



[11]



All specifications are at room temperature unless otherwise specified.
In the interest of constant product improvement, we reserve the right to change specifications without notice.
ICP® is a registered trademark of PCB Piezotronics, Inc.

Entered: ND	Engineer: NJF	Sales: JL	Approved: NJF	Spec Number:
Date: 07/06/2023	Date: 07/06/2023	Date: 07/06/2023	Date: 07/06/2023	37423



IMI Sensors
3425 Walden Depew, NY 14043
UNITED STATES
Phone: 800-959-4464
Fax: 716-684-3823
E-Mail: imi@pcb.com
Web site: http://www.imi-sensors.com

PCB Piezotronics Inc. claims proprietary rights in the information disclosed hereon. Neither it nor any reproduction thereof will be disclosed to others without the written consent of PCB Piezotronics Inc.

REVISIONS

REV	DESCRIPTION	ECN	APP'D
NR	RELEASED TO DRAFTING		ECB 5/17/07

37424

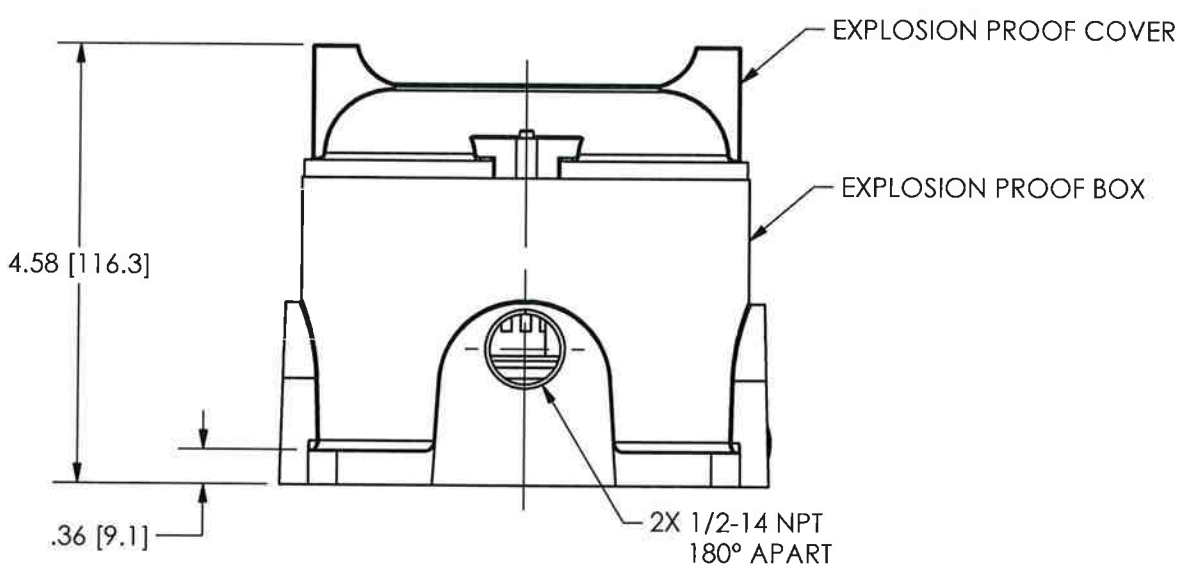
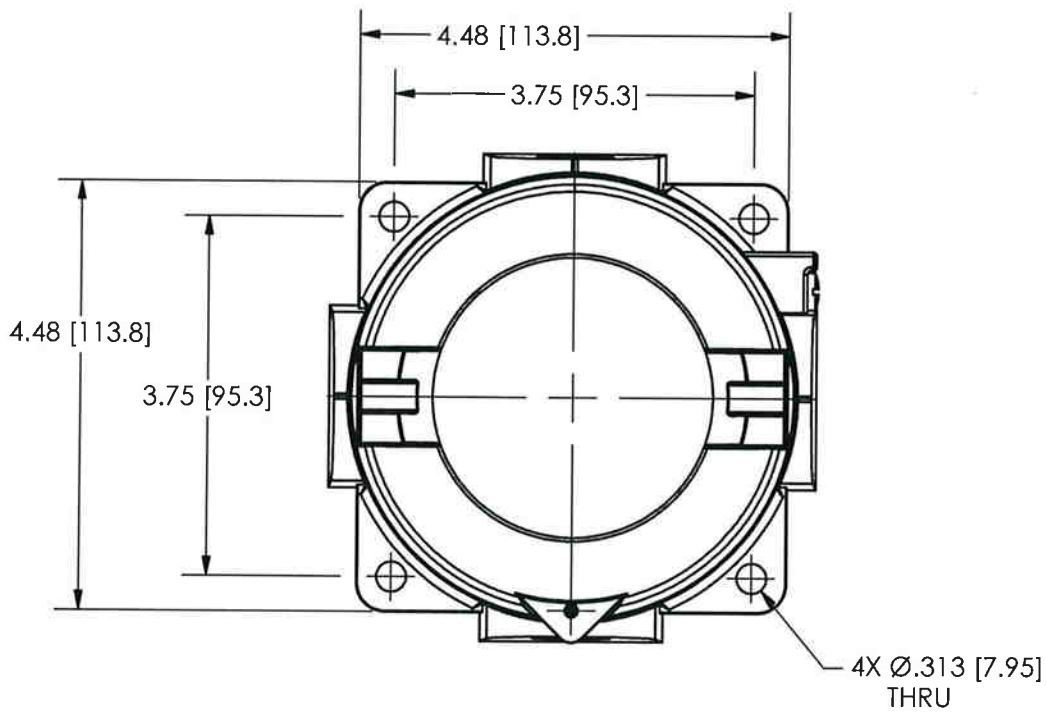

UNLESS OTHERWISE SPECIFIED TOLERANCES ARE:

DIMENSIONS IN INCHES	DIMENSIONS IN MILLIMETERS [IN BRACKETS]
DECIMALS XX ± .03	DECIMALS X ± 0.8
XXX ± .010	XX ± 0.25
ANGLES ± 2 DEGREES	ANGLES ± 2 DEGREES

DRAWN	<i>JMB</i>	3/15/07	MFG	<i>DAL</i>	5/16/07
CHK'D	ECB	5/17/07	ENGR	MRE	5/16/07
APP'D	ZAB	5/16/07	SALES	<i>JA</i>	5/16/07
TITLE					

PCB PIEZOTRONICS™
 3425 WALDEN AVE. DEPEW, NY 14043
 (716) 684-0001 E-MAIL: sales@pcb.com

OUTLINE DRAWING
 MODEL 685BXXXXC14
 ELECTRONIC VIBRATION SWITCH

CODE IDENT. NO. 52681	DWG NO. 37424
SCALE: .5X	SHEET 1 OF 1



LCIE

1 ATTESTATION D'EXAMEN CE DE TYPE

2 **Appareil ou système de protection** destiné à être utilisé en atmosphères explosibles (**Directive 94/9/CE**)

3 Numéro de l'attestation d'examen CE de type
LCIE 10 ATEX 3065

4 Appareil ou système de protection :
Interrupteur de vibrations
Type : 685 series

5 Demandeur : IMI / PCB Piezotronics
Adresse : 3425 Walden Avenue,
Depew, New York 14043 USA

6 Fabricant : IMI / PCB Piezotronics
Adresse : 3425 Walden Avenue,
Depew, New York 14043 USA

7 Cet appareil ou système de protection et ses variantes éventuelles acceptées sont décrits dans l'annexe de la présente attestation et dans les documents descriptifs cités en référence.

8 Le LCIE, organisme notifié sous la référence 0081 conformément à l'article 9 de la directive 94/9/CE du Parlement européen et du Conseil du 23 mars 1994, certifie que cet appareil ou système de protection est conforme aux exigences essentielles de sécurité et de santé pour la conception et la construction d'appareils et de systèmes de protection destinés à être utilisés en atmosphères explosibles, données dans l'annexe II de la directive. Les résultats des vérifications et essais figurent dans le rapport confidentiel N°100224/599267.

9 Le respect des exigences essentielles de sécurité et de santé est assuré par la conformité à :
- EN 60079-0 (2006),
- EN 60079-1 (2007)

10 Le signe X lorsqu'il est placé à la suite du numéro de l'attestation, indique que cet appareil ou système de protection est soumis aux conditions spéciales pour une utilisation sûre, mentionnées dans l'annexe de la présente attestation.

11 Cette attestation d'examen CE de type concerne uniquement la conception et la construction de l'appareil ou du système de protection spécifié, conformément à l'annexe III de la directive 94/9/CE. Des exigences supplémentaires de la directive sont applicables pour la fabrication et la fourniture de l'appareil ou du système de protection. Ces dernières ne sont pas couvertes par la présente attestation.

12 Le marquage de l'appareil ou du système de protection doit comporter les informations détaillées au point 15.

Fontenay-aux-Roses, le 20 juillet 2010

1 EC TYPE EXAMINATION CERTIFICATE

2 **Equipment or protective system** intended for use in potentially explosive atmospheres (**Directive 94/9/EC**)

3 EC type examination certificate number
LCIE 10 ATEX 3065

4 Equipment or protective system :
Vibration switches
Type : 685 series

5 Applicant : IMI / PCB Piezotronics
Address : 3425 Walden Avenue,
Depew, New York 14043 USA

6 Manufacturer : IMI / PCB Piezotronics
Address : 3425 Walden Avenue,
Depew, New York 14043 USA

7 This equipment or protective system and any acceptable variation thereto are specified in the schedule to this certificate and the documents therein referred to.

8 LCIE, notified body number 0081 in accordance with article 9 of the Directive 94/9/EC of the European Parliament and the Council of 23 March 1994, certifies that this equipment or protective system has been found to comply with the essential Health and Safety Requirements relating to the design and construction of equipment and protective systems intended for use in potentially explosive atmospheres, given in Annex II to the Directive. The examination and test results are recorded in confidential report N°100224/599267.

9 Compliance with the Essential Health and Safety Requirements has been assured by compliance with :
- EN 60079-0 (2006),
- EN 60079-1 (2007)

10 If the sign X is placed after the certificate number, it indicates that the equipment or protective system is subject to special conditions for safe use specified in the schedule to this certificate.

11 This EC type examination certificate relates only to the design and construction of this specified equipment or protective system in accordance with annex III to the directive 94/9/EC. Further requirements of the directive apply to the manufacturing process and supply of this equipment or protective system. These are not covered by this certificate.

12 The marking of the equipment or protective system shall include information as detailed at 15.

Le responsable de certification ATEX
ATEX certification manager

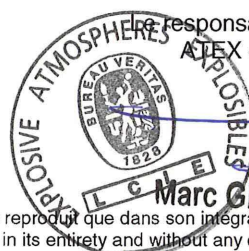

Marc GILLAUX

Seul le texte en français peut engager la responsabilité du LCIE. Ce document ne peut être reproduit que dans son intégralité, sans aucune modification
The LCIE's liability applies only on the French text. This document may only be reproduced in its entirety and without any change

Page 1 of 2

01-Annexe III_CE_typ_app - rev1.DOC

**13 ANNEXE****13 SCHEDULE****14 ATTESTATION D'EXAMEN CE DE TYPE****14 EC TYPE EXAMINATION CERTIFICATE****LCIE 10 ATEX 3065****LCIE 10 ATEX 3065****15 DESCRIPTION DE L'APPAREIL OU DU SYSTEME DE PROTECTION****15 DESCRIPTION OF EQUIPMENT OR PROTECTIVE SYSTEM**

Interrupteur de vibrations
Type : 685 series

Vibration switches
Type : 685 series

Le matériel est composé d'une enveloppe métallique antidéflagrante contenant une carte électronique.

The apparatus is made of a metallic flameproof enclosure including an electronic board.

Paramètres spécifiques du ou des modes de protection concernés :

Specific parameters of the mode(s) of protection concerned :

Alimentation :

- version AC : 85-245Vac, 50/60Hz, 150mA max
- version DC : 24Vdc (+/-10%), 150mA max

Sortie relais :

- 245Vac, 10A ac
- 30Vdc, 5A
- Sortie TRIAC : 245Vac, 5Aac

Power supply :

- version AC : 85-245Vac, 50/60Hz, 150mA max
- version DC : 24Vdc (+/-10%), 150mA max

Relay output:

- 245Vac, 10A ac
- 30Vdc, 5A
- TRIAC output: 245Vac, 5Aac

Le marquage doit être :

IMI ou PCB Piezotronics

Adresse : ...

Type : 685... (1)

N° de fabrication : ... Année de fabrication : ...

 II 2G Ex d IIB + H2 T4

LCIE 10 ATEX 3065

T amb : -25°C à +70°C

AVERTISSEMENT-NE PAS OUVRIR SOUS TENSION

(1) complété par le modèle

The marking shall be :

IMI or PCB Piézotronics

Address : ...

Type : 685 ... (1)

Serial number : ... Year of construction : ...

 II 2G Ex d IIB + H2 T4

LCIE 10 ATEX 3065

T amb : -25°C to +70°C

WARNING-DO NOT OPEN WHEN ENERGIZED

(1) completed with the model

L'appareil doit également comporter le marquage normalement prévu par les normes de construction qui le concerne.

The equipment shall also bear the usual marking required by the manufacturing standards applying to such equipment.

16 DOCUMENTS DESCRIPTIFS

Dossier technique n°46198 rév.NR du 16/06/10.
Ce document comprend 7 rubriques (14 pages).

16 DESCRIPTIVE DOCUMENTS

Technical file n°46198 rev NR dated 06/16/10.
This file includes 7 items (14 pages).

17 CONDITIONS SPECIALES POUR UNE UTILISATION SÛRE

Néant.

17 SPECIAL CONDITIONS FOR SAFE USE

None.

18 EXIGENCES ESSENTIELLES DE SECURITE ET DE SANTE

Couvertes par les normes listées au point 9.

18 ESSENTIAL HEALTH AND SAFETY REQUIREMENTS

Covered by standards listed at 9.

19 VERIFICATIONS ET ESSAIS INDIVIDUELS

Néant.

19 ROUTINE VERIFICATIONS AND TESTS

None.

20 CONDITIONS DE CERTIFICATION

Les détenteurs d'attestations d'examen CE de type doivent également satisfaire les exigences de contrôle de production telles que définies à l'article 8 de la directive 94/9/CE.

20 CONDITIONS OF CERTIFICATION

Holders of EC type examination certificates are also required to comply with the production control requirements defined in article 8 of directive 94/9/EC.



Certificate of Compliance

Certificate: 1819674 **Master Contract:** 184981 (103164_0_000)
Project: 70156145 **Date Issued:** 2017-10-27
Issued to: Industrial Monitoring Instr. (IMI) A Div. of PCB Piezotronics, Inc.
3425 Walden Ave
Depew, New York 14043
USA
Attention: Carrie Termin

The products listed below are eligible to bear the CSA Mark shown with adjacent indicators 'C' and 'US' for Canada and US or with adjacent indicator 'US' for US only or without either indicator for Canada only.



Issued by: *Thong Tong*
Thong Tong

PRODUCTS

CLASS - C225802 - PROCESS CONTROL EQUIPMENT-For Hazardous Locations-
CLASS - C225882 - PROCESS CONTROL EQUIPMENT-For Hazardous Locations - Certified to US Standards

Class I, Div. 1, Groups B, C and D; Class II, Div. 1, Groups E, F and G; Class III, Div. 1

Model 685B0X01C14 Electronic Vibration Switch; input supply rated 85-245 Vac, 50/60 Hz, 150 mA max; Output (optional) rated 15 Vdc, 4-20 mA; 5 Vdc, 1 mA; Relay Contact Rated 245 Vac, 10A; 30 Vdc, 5A; Temperature Code T6; -25 Deg. C \leq Ambient \leq + 70 Deg. C; installed as per Interconnection drawing 34917; Enclosure Type 4; IP 66.

Notes:

X- is a number that indicates Range, Frequency Response, and number of conduit hubs.

Class I, Div. 2, Groups A, B, C and D
Class I, Zone 2 Group IIC; T6 (optional)

Model 685B0X01A11, 685B0X01A13, 685B0X01D11, 685B0X01D13, and CS685YZZZ Electronic Vibration Switch; input supply rated 85-245 Vac, 50/60 Hz, 150 mA max; Output (optional) rated 15 Vdc, 4-20 mA; 5 Vdc, 1 mA; Relay Contact Rated 245 Vac, 10A; 30 Vdc, 5A; Temperature Code T6; -30 Deg. C \leq Ambient \leq + 70 Deg. C; installed as per Interconnection drawing 37476; Enclosure Type 4X.



Certificate: 1819674
Project: 70156145

Master Contract: 184981
Date Issued: 2017-10-27

Notes:

X- is a number that indicates Range, Frequency Response, and number of conduit hubs.

Y- is one letter A to Z Denoting Model Revision level (Minor Revisions not affecting approvals)

ZZZ- Two or three numbers 00 to 999 which depicts sensitivity, filtering, or special sequential number (up to three digits)

Model 685B0X00A11, 685B0X00A13, 685B0X00D11, 685B0X00D13, and CS685YZZZ Electronic Vibration Switch; input supply rated 85-245 Vac, 50/60 Hz, 150 mA max; Output (optional) rated 15 Vdc, 4-20 mA; 5 Vdc, 1 mA; Triac output Contact Rated 245 Vac, 5A; Temperature Code T6; -30 Deg. C \leq Ambient \leq + 70 Deg. C; installed as per Interconnection drawing 37476; Enclosure Type 4X.

Notes:

X- is a number that indicates Range, Frequency Response, and number of conduit hubs.

Y- is one letter A to Z Denoting Model Revision level (Minor Revisions not affecting approvals)

ZZZ- Two or three numbers 00 to 999 which depicts sensitivity, filtering, or special sequential number (up to three digits)

APPLICABLE REQUIREMENTS

- CAN/CSA-C22.2 No. 0-M91 - General Requirements – Canadian Electrical Code, Part II
- C22.2 No. 25-1966 - Enclosures for Use in Class II, Groups E, F and G Hazardous Locations
- C22.2 No. 30-M1986 - Explosion-Proof Enclosures for Use in Class I Hazardous Locations
- CAN/CSA-C22.2 No. 94-M91 - Special Purpose Enclosures
- C22.2 No. 142-M1987 - Process Control Equipment
- C22.2 No. 213-M1987 - Non-Incendive Electrical Equipment for Use in Class I, Division 2 Hazardous Locations
- CAN/CSA-C22.2 No. 60529:05 - Degrees of protection provided by enclosures (IP Code)
- UL 50, 11th Ed. - Enclosures for Electrical Equipment
- UL 916, 3rd Ed. - Energy Management Equipment
- UL 1203, 4th Ed. - Explosion-Proof and Dust-Ignition-Proof Electrical Equipment for Use in Hazardous (Classified) Locations
- UL 1604 (3rd Ed.) - Electrical Equipment for Use in Class I and II, Division 2; Class III Hazardous (Classified) Locations
- ANSI/ISA 12.12.01-2000 - Nonincendive Electrical Equipment for Use in Class I and II, Division 2 and Class III, Divisions 1 and 2 Hazardous (Classified) Locations
- ANSI/IEC 60529:2004 - Degrees of Protection Provided by Enclosures (IP Code)



Certificate: 1819674
Project: 70156145

Master Contract: 184981
Date Issued: 2017-10-27

MARKINGS

The manufacturer is required to apply the following markings:

- Products shall be marked with the markings specified by the particular product standard.
- Products certified for Canada shall have all Caution and Warning markings in both English and French.

Additional bilingual markings not covered by the product standard(s) may be required by the Authorities Having Jurisdiction. It is the responsibility of the manufacturer to provide and apply these additional markings, where applicable, in accordance with the requirements of those authorities.

The products listed are eligible to bear the CSA Mark shown with adjacent indicators 'C' and 'US' for Canada and US (indicating that products have been manufactured to the requirements of both Canadian and U.S. Standards) or with adjacent indicator 'US' for US only or without either indicator for Canada only.

Nameplate adhesive label material approval information:

Marking details for the model 685B0X01C14 are etched onto a minimum 0.02 inch thick metal nameplate, secured in bottomed holes, to the enclosure cover with screws, drive pins or rivets.

The following marking details appear:

Model 685B0X01C14

- CSA Monogram with C/US
- Company Name
- Model number
- Serial number
- Electrical Input ratings
- Electrical Output ratings
- Relay Contact ratings
- Hazardous Location designation
- Min. and Max. ambient rating
- Reference to Installation Drawing
- Caution re. Keep cover tight while circuits are alive
- Caution re. Seal Required within 18 inches
- Caution: The relay outputs may be connected to different phases only for voltages up to 125Vac. For voltages above 125Vac, the relays shall be connected to same phase circuit only (appears in referenced Installation Drawing).

Marking details for the model 685B0X01A1X and model 685B0X00A1X are etched directly onto the top of the Enclosure Cover.

The following marking details appear:



Certificate: 1819674
Project: 70156145

Master Contract: 184981
Date Issued: 2017-10-27

Model 685B0X01A1X

- CSA Monogram with C/US
- Company Name
- Model number
- Serial number
- Electrical Input ratings
- Electrical Output ratings
- Relay Contact ratings
- Hazardous Location designation
- Class I, Zone 2 Group IIC; T6 (optional)
- Min. and Max. ambient rating
- Reference to Installation Drawing
- Caution re. Keep cover tight while circuits are alive
- Caution: The relay outputs may be connected to different phases only for voltages up to 125Vac. For voltages above 125Vac, the relays shall be connected to same phase circuit only (appears in referenced Installation Drawing).

Model 685B0X00A1X

- CSA Monogram with C/US
- Company Name
- Model number
- Serial number
- Electrical Input ratings
- Electrical Output ratings
- Triac Contact ratings
- Hazardous Location designation
- Class I, Zone 2 Group IIC; T6 (optional)
- Min. and Max. ambient rating
- Reference to Installation Drawing
- Caution re. Keep cover tight while circuits are alive
- Caution: The triac outputs may be connected to different phases only for voltages up to 125Vac. For voltages above 125Vac, the relays shall be connected to same phase circuit only (appears in referenced Installation Drawing).

ALTERATIONS

1. Markings as above appear.
2. Enclosure base floor is machined such that a minimum of 0.25 inches of wall thickness remains on the bottom.
3. Enclosure ground post is provided with a cup-washer (for wire retention means).
4. Conduit hubs are used on the model 685B0X01A1x and 685B0X01D1x are Cooper/Crouse Hinds/Myer P/N ST-1 and/or STA-1.
5. NBR Gasket is not used for models 685B0X01A1X and 685B0X00A1X.



Supplement to Certificate of Compliance

Certificate: 1819674

Master Contract: 184981 (103164_0_000)

*The products listed, including the latest revision described below,
are eligible to be marked in accordance with the referenced Certificate.*

Product Certification History

Project	Date	Description
70156145	2017-10-27	Update to existing report 1819674 to add Electronic Vibration Switch Model CS685YZZZ. The proposed CS685YZZZ is identical to the 685B0X01A13 model except that the enclosure is larger to accommodate a larger customer requested conduit hub (single hub configuration).
70118605	2017-08-31	Project closed incomplete. No report/CofC issued
1916501	2007-10-11	Update to include Model 685B0X01A1x, 685B0X01D1x, 685B0X00A1x and 685B0X00D1x (Division 2 version of Electronic Vibration Switch) for hazardous locations.
1819674	2007-04-27	Model 685B0X01C14 Electronic Vibration Switch - Explosion-proof for Hazardous Locations.



СЕРТИФИКАТ СООТВЕТСТВИЯ

№ ЕАЭС RU C-US.AA87.B.00217/19

Серия **RU** № **0124866**



ОРГАН ПО СЕРТИФИКАЦИИ Орган по сертификации взрывозащищенного и рудничного оборудования (ОС ЦСВЭ) Общества с ограниченной ответственностью «Центр по сертификации взрывозащищенного и рудничного оборудования» (ООО «НАНИО ЦСВЭ»). Адрес места нахождения юридического лица: Россия, 140004, Московская область, Люберецкий район, город Люберцы, поселок ВУГИ, АО «Завод «ЭКОМАШ», литера В, Объект 6, этаж 3, офис 26. Адрес места осуществления деятельности в области аккредитации: Россия, 140004, Московская область, Люберецкий район, город Люберцы, поселок ВУГИ, АО «Завод «ЭКОМАШ», Литера В, Объект 6, этаж 3, офисы 26/3, 26/4, 26/5, 27/6, 30/1, 32. Аттестат № RA.RU.11AA87 от 20.07.2015 г. Телефон: +7 (495) 558-83-53, +7 (495) 558-82-44. Адрес электронной почты: ccve@ccve.ru

ЗАЯВИТЕЛЬ Общество с ограниченной ответственностью «Альфатех». Адрес места нахождения юридического лица: Россия, 125009, Москва, Малый Гнезниковский переулок, дом № 12, помещение I, комната 4. Адрес места осуществления деятельности: Россия, 127495, Москва, Долгопрудненское шоссе, дом № 3, Технопарк «Физтехпарк». ОГРН: 1167746393792. Телефон: +7 (495) 642-49-14. Адрес электронной почты: info@alphatechgroup.ru

ИЗГОТОВИТЕЛЬ PCB Piezotronics, Inc
Адрес места нахождения юридического лица и адрес места осуществления деятельности по изготовлению продукции: 3425 Walden Av., Depew, NY 14043, США

ПРОДУКЦИЯ Пьезоэлектрические преобразователи, вибропереключатели, предусилители с Ex-маркировкой согласно приложению (см. бланки №№ 0621345, 0621346, 0621347). Документы, в соответствии с которыми изготовлены изделия – см. приложение, бланк № 0621344. Серийный выпуск.

КОД ТН ВЭД ЕАЭС 9031 80 3800, 9026 20 2000, 8517 69 9000

СООТВЕТСТВУЕТ ТРЕБОВАНИЯМ
ТР ТС 012/2011 «О безопасности оборудования для работы во взрывоопасных средах».

СЕРТИФИКАТ СООТВЕТСТВИЯ ВЫДАН НА ОСНОВАНИИ
Протокола испытаний № 235.2019-Т от 11.09.2019 Испытательной лаборатории технических устройств Автономной некоммерческой организации «Национальный испытательный и научно-исследовательский институт оборудования для взрывоопасных сред» ИЛ Ex TU (аттестат № РОСС RU.0001.21MШ19 от 16.10.2015); Акта анализа состояния производства № 35-А/19 от 14.03.2019 Органа по сертификации взрывозащищенного и рудничного оборудования (ОС ЦСВЭ) Общества с ограниченной ответственностью «Центр по сертификации взрывозащищенного и рудничного оборудования» (ООО «НАНИО ЦСВЭ») (аттестат № RA.RU.11AA87 выдан 20.07.2015); Документов, представленных заявителем в качестве доказательства соответствия продукции требованиям ТР ТС 012/2011 (см. приложение, бланк № 0621344).
Схема сертификации – 1с.

ДОПОЛНИТЕЛЬНАЯ ИНФОРМАЦИЯ
Перечень стандартов, применяемых на добровольной основе для соблюдения требований ТР ТС 012/2011 (см. приложение, бланк № 0621344). Условия и срок хранения указаны в эксплуатационной документации. Назначенный срок службы – 10 лет.

СРОК ДЕЙСТВИЯ С 13.09.2019 ПО 12.09.2024
ВКЛЮЧИТЕЛЬНО

Руководитель (уполномоченное лицо) органа по сертификации

(подпись)

Залогин Александр Сергеевич

(Ф.И.О.)

Эксперт (эксперт-аудитор) (эксперты (эксперты-аудиторы))

(подпись)

М.П. Рафалович Борис Александрович

(Ф.И.О.)

ПРИЛОЖЕНИЕ

К СЕРТИФИКАТУ СООТВЕТСТВИЯ № БАЭС RU C-US.AA87.B.00217/19 Лист 1

Серия RU № 0621344

**I. ПЕРЕЧЕНЬ СТАНДАРТОВ, ПРИМЕНЯЕМЫХ НА ДОБРОВОЛЬНОЙ ОСНОВЕ
ДЛЯ СОБЛЮДЕНИЯ ТРЕБОВАНИЙ ТР ТС 012/2011 «О БЕЗОПАСНОСТИ ОБОРУДОВАНИЯ
ДЛЯ РАБОТЫ ВО ВЗРЫВООПАСНЫХ СРЕДАХ»**

Обозначение стандартов	Наименование стандартов
ГОСТ 31610.0-2014 (IEC 60079-0:2011)	Взрывоопасные среды. Часть 0. Оборудование. Общие требования
ГОСТ IEC 60079-1-2011	Взрывоопасные среды. Часть 1. Оборудование с видом взрывозащиты «взрывонепроницаемые оболочки «d»
ГОСТ 31610.11-2014 (IEC 60079-11:2011)	Взрывоопасные среды. Часть 11. Оборудование с видом взрывозащиты «искробезопасная электрическая цепь «i»
ГОСТ 31610.15-2012/МЭК 60079-15:2005	Электрооборудование для взрывоопасных газовых сред. Часть 15. Конструкция, испытания и маркировка электрооборудования с видом защиты «п»

**II. ДОКУМЕНТЫ, ПРЕДСТАВЛЕННЫЕ ЗАЯВИТЕЛЕМ В КАЧЕСТВЕ ДОКАЗАТЕЛЬСТВА
СООТВЕТСТВИЯ ПРОДУКЦИИ ТРЕБОВАНИЯМ ТР ТС 012/2011**

Руководства по эксплуатации: № 750119 от 23.01.19, № 830119 от 23.01.19, № 940219 от 07.02.19, № 630119 от 22.01.19, № 610119 от 22.01.19, № 910219 от 07.02.19, № 950219 от 08.02.19, № 970219 от 08.02.19.
Технические файлы: № 54202 от 02.02.2017, № 54204 от 02.02.2017, № 22438 С от 19.07.2012, № 62501 от 06.10.2016, № 33699 от 16.06.2016, № 56178 от 01.07.2016, № 70893 от 24.07.2019, № 54707 от 10.08.2016, № 48813 от 06.01.2011
Чертежи: № 47912 от 31.03.2017, № 49038 от 31.03.2017.
Перечень стандартов см. п. I.

III. ДОКУМЕНТЫ, В СООТВЕТСТВИИ С КОТОРЫМИ ИЗГОТОВЛЕНА ПРОДУКЦИЯ

Технические файлы: № 54202 от 02.02.2017, № 54204 от 02.02.2017, № 22438 С от 19.07.2012, № 62501 от 06.10.2016, № 33699 от 16.06.2016, № 56178 от 01.07.2016, № 70893 от 24.07.2019, № 54707 от 10.08.2016, № 48813 от 06.01.2011
Чертежи: № 47912 от 31.03.2017, № 49038 от 31.03.2017

Руководитель (уполномоченное
лицо) органа по сертификации

(подпись)

Эксперт (эксперт-аудитор)
(эксперты (эксперты-аудиторы))

(подпись)



Залогин Александр Сергеевич
(Ф.И.О.)

М.П.

Рафалович Борис Александрович
(Ф.И.О.)

ПРИЛОЖЕНИЕ

К СЕРТИФИКАТУ СООТВЕТСТВИЯ № ЕАЭС RU C-US.AA87.B.00217/19 Лист 2

Серия RU № 0621345

1. НАЗНАЧЕНИЕ И ОБЛАСТЬ ПРИМЕНЕНИЯ

Пьезоэлектрические преобразователи (далее – преобразователи) предназначены для контроля параметров вибрации, динамического давления и преобразования их в электрический сигнал.

Вибропереключатели предназначены для контроля уровня вибрации и защиты оборудования от повышенной вибрации.

Предусилители предназначены для преобразования зарядового сигнала в вольтовый.

Область применения - взрывоопасные зоны помещений и наружных установок согласно Ex-маркировке, ГОСТ IEC 60079-14-2013, регламентирующих применение во взрывоопасных средах.

2. СТРУКТУРНОЕ ОБОЗНАЧЕНИЕ

2.1. Преобразователи 176ХУУ/МZZZ-АА

X = от А до Z ревизия продукта, не влияющая на взрывозащиту

УУ = от 01 до 99 для индикации вариантов монтажа, диафрагмы, кабелей или разъемов

M = опционально для указания метрической длины кабеля

ZZZ = от 001 до 999 опционально для указания длины кабеля в футах: (не более 200 футов) или метрах: (не более 61 м)

AA = от 01 до 99 опционально для указания дробной длины кабеля в дюймах или сантиметрах, не влияющей на взрывозащиту

2.2. Преобразователи 351abcd

a – ревизия продукта, может быть: А,В,С,Д,Е,Ф,Г,Н,І,Ј,К,Л или М, не влияющая на взрывозащиту

b – первая цифра вариации продукта, может быть: 0,1,2,3,4,5,6,7,8 или 9, не влияющая на взрывозащиту

c – вторая цифра вариации продукта, может быть: 0,1,2,3,4,5,6,7,8 или 9, не влияющая на взрывозащиту

d – третья цифра вариации продукта, может быть: 0,1,2,3,4,5,6,7,8,9 или отсутствует, не влияющая на взрывозащиту

2.3 Преобразователи EX(TO)(M)602yzzz1aaa, EX(TO)(M)603yzzz/aaa, EX(TO)(M)606yzzz/aaa, EX(TO)(M)607yzzz/aaa, EX(TO)(M)608yzzz/aaa, EX(M)637XYYYZ, (M)638XYYYZ

XX = TO (с температурным выходом), M (с метрической резьбой),

y = одна буква от А до Z, не влияющая на взрывозащиту

zzz = две или три цифры от 00 до 999, не влияющие на взрывозащиту

aaa = длина кабеля и/или тип разъема

2.4 Предусилители EX682XYYY

X – ревизия продукта (А,В ... М), не влияющая на взрывозащиту

YYY: параметры фильтрации, усиления, частотная характеристика, ... (от 1 до 999), не влияющие на взрывозащиту

2.5 Преобразователи EX(RV)(TO)(M)64хухх, EX(RV)(TO)(M)649ухх, EX (RV)(TO) (M)686ухх

XX = M (с метрической резьбой), TO (с температурным выходом), RV (с доп. вольтовым выходом).

Буквы х являются переменными цифрами (значения от 0 до 9), не влияющими на взрывозащиту

y = одна буква от А до Z, не влияющая на взрывозащиту

2.6 Преобразователи EX (XX) 622yzzz / aaa, EX (XX) 623yzzz / aaa, EX (XX) 625yzzz / aaa, EX (XX) 628yzzz / aaa

XX = HT (Высокотемпературная версия), M (с метрической резьбой), TO (с температурным выходом), VO (с выходом по скорости).

y = одна буква от А до Z, не влияющая на взрывозащиту

zzz = две или три цифры от 00 до 999, не влияющие на взрывозащиту

aaa = длина кабеля и/или тип разъема

2.7 Вибропереключатели 685ухх

Буквы х являются переменными цифрами (значения от 0 до 9), не влияющими на взрывозащиту

y = одна буква от А до Z, не влияющая на взрывозащиту

Руководитель (уполномоченное
лицо) органа по сертификации

(подпись)

Залогин Александр Сергеевич
(Ф.И.О.)

Эксперт (эксперт-аудитор)
(эксперты (эксперты-аудиторы))

(подпись)

Рафалович Борис Александрович
(Ф.И.О.)

ПРИЛОЖЕНИЕ

К СЕРТИФИКАТУ СООТВЕТСТВИЯ № ЕАЭС RU C-US.AA87.B.00217/19 Лист 3

Серия **RU** № **0621346**

3. ОСНОВНЫЕ ТЕХНИЧЕСКИЕ ДАННЫЕ

3.1. Ех-маркировка: преобразователей 176XYU/MZZ-AA	0Ex ia IIC T660°C...T6 Ga X
преобразователей 351abcd	0Ex ia IIC T4 Ga X
вибродвигателей 685yxx	1Ex d IIB+H2 T4 Gb
преобразователей EX(TO)(M)602yzzz1aaa, EX(TO)(M)603yzzz/aaa, EX(TO)(M)606yzzz/aaa, EX(TO)(M)607yzzz/aaa, EX(TO)(M)608yzzz/aaa	2Ex nA IIC T4 Gc X или 0Ex ia IIC T4 Ga X
преобразователей EX(M)637XYUZY, (M)638XYUZY	0Ex ia IIC T4 Ga X или 2Ex nA IIC T4 Gc X
предусилителей EX682XYUZY	0Ex ia IIC T4 Ga X или 2Ex nA IIC T4 Gc X
EX(RV)(TO)(M)64хухх, EX(RV)(TO)(M)649ухх, EX (RV)(TO) (M)686ухх	1Ex d IIC T4 Gb X или 1Ex d IIC T3 Gb X
преобразователей EX (XX) 622yzzz / aaa, EX (XX) 623yzzz / aaa, EX (XX) 625yzzz / aaa , EX (XX) 628yzzz / aaa	2Ex nA IIC T4 Gc X
3.2. Диапазон температур окружающей среды, °С, преобразователей 176XYU/MZZ-AA	от -70 до 650
преобразователей 351abcd	от -196 до 121
вибродвигателей 685yxx	от -25 до 60
преобразователей EX(TO)(M)602yzzz1aaa, EX(TO)(M)603yzzz/aaa, EX(TO)(M)606yzzz/aaa, EX(TO)(M)607yzzz/aaa, EX(TO)(M)608yzzz/aaa	от -54 до 121
преобразователей EX(M)637XYUZY, (M)638XYUZY	от -196 до 121
предусилителей EX682XYUZY	от -40 до 85
преобразователей EX(RV)(TO)(M)64хухх, EX(RV)(TO)(M)649ухх, EX (RV)(TO) (M)686ухх	от -20 до 80
преобразователей EX (XX) 622yzzz / aaa, EX (XX) 623yzzz / aaa, EX (XX) 625yzzz / aaa , EX (XX) 628yzzz / aaa	от -54 до 121

3.3. Входные искробезопасные электрические параметры преобразователей, предусилителей:

Модель	U _i , В	I _i , мА	P _i , Вт	C _i , нФ	L _i , мГн
преобразователей 176XYU/MZZ-AA	30	300	1	5	0,5
преобразователей 351abcd	28	200	1,2	61	305 мкГн
преобразователей EX(TO)(M)602yzzz1aaa, EX(TO)(M)603yzzz/aaa, EX(TO)(M)606yzzz/aaa, EX(TO)(M)607yzzz/aaa, EX(TO)(M)608yzzz/aaa	28	200	1	16,2 или 77,2 (с кабелем)	пренебрежимо мала или 305 мкГн (с учетом кабеля 305м)
преобразователей EX(M)637XYUZY, (M)638XYUZY	28	93	0,65	6,5	пренебрежимо мала
предусилителей EX682XYUZY	28	100	0,7	пренебрежимо мала	пренебрежимо мала

Руководитель (уполномоченное
лицо) органа по сертификации

(подпись)

Эксперт (эксперт-аудитор)
(эксперты (эксперты-аудиторы))

(подпись)

Залогин Александр Сергеевич

(Ф.И.О.)

М.П. Рафалович Борис Александрович

(Ф.И.О.)

ПРИЛОЖЕНИЕ

К СЕРТИФИКАТУ СООТВЕТСТВИЯ № ЕАЭС RU C-US.AA87.B.00217/19 Лист 4

Серия RU № 0621347

3.4. Электрические параметры:

3.4.1 вибропереключателей 685ухх

Напряжение питания, В 85-245 (AC), 24 (DC)
Максимальный ток, mA 150

3.4.2 преобразователей EX(TO)(M)602yzzz/aaa, EX(TO)(M)603yzzz/aaa, EX(TO)(M)606yzzz/aaa, EX(TO)(M)607yzzz/aaa, EX(TO)(M)608yzzz/aaa, EX (XX) 622yzzz / aaa, EX (XX) 623yzzz / aaa, EX (XX) 625yzzz / aaa, EX (XX) 628yzzz / aaa

с Ex-маркировкой 2Ex nA IIC T4 Gc X:

Напряжение питания, В 28
Максимальный ток, mA 200
Мощность, Вт 1

3.4.3 преобразователей EX(M)637XYYYZ, (M)638XYYYZ

Напряжение питания, В 18 – 28
Максимальный ток, mA 1,6 – 20
Мощность, Вт 0,5

3.4.4 Предусилителей EX682XYYY

Напряжение питания, В 22 – 28
Максимальный ток, mA 3,1 – 4,1
Мощность, Вт 0,1

3.4.5 преобразователей EX(RV)(TO)(M)64уххх, EX(RV)(TO)(M)649ухх, EX (RV)(TO) (M)686ухх

Напряжение питания, В 18 – 30
Максимальный ток, mA 1,6 – 20
Мощность, Вт 0,5

4. ОПИСАНИЕ КОНСТРУКЦИИ И СРЕДСТВ ОБЕСПЕЧЕНИЯ ВЗРЫВОЗАЩИЩЕННОСТИ

Преобразователи состоят из герметичного цилиндрического металлического корпуса, в котором размещается печатная плата и пьезокристаллический элемент. Сборка подключается к разъему или встроенному кабелю. На наружной поверхности корпуса преобразователя нанесена маркировка.

Вибропереключатели серии 685ухх выполнены в металлическом корпусе, внутри которого размещена электронная плата. На наружной поверхности корпуса нанесена маркировка.

Предусилители серии EX682XYYY выполнены в прямоугольном пластиковом корпусе с креплением на DIN рейку. Внутри корпуса размещена электронная плата. На корпусе размещен съемный клеммный блок. На наружной поверхности корпуса нанесена маркировка.

Подробное описание конструкции приведено в Руководствах по эксплуатации №750119 от 23.01.19, №830119 от 23.01.19, №940219 от 07.02.19, №630119 от 22.01.19, №610119 от 22.01.19, №910219 от 07.02.19, №950219 от 08.02.19, №970219 от 08.02.19

Взрывозащищенность преобразователей, вибропереключателей и предусилителей обеспечивается выполнением требований: ГОСТ 31610.15-2012/МЭК 60079-15:2005, ГОСТ 31610.0-2014 (IEC 60079-0:2011), ГОСТ IEC 60079-1-2011, ГОСТ 31610.11-2014 (IEC 60079-11:2011), в соответствии с Ex-маркировкой.

5. МАРКИРОВКА

Маркировка, наносимая на преобразователи, вибропереключатели и предусилители, включает следующие данные:

- товарный знак или наименование предприятия-изготовителя;
- серийный номер или номер партии;
- диапазон значений температур окружающей среды при эксплуатации;
- Ex-маркировку;
- специальный знак взрывобезопасности;
- наименование центра по сертификации и номер сертификата;
- предупредительные надписи;
- искробезопасные параметры

и другие данные, которые изготовитель должен отразить в маркировке, в соответствии с требованиями нормативной и технической документации.

6. СПЕЦИАЛЬНЫЕ УСЛОВИЯ ПРИМЕНЕНИЯ

5.1 Знак X, стоящий после Ex-маркировки, означает, что при эксплуатации преобразователей, вибропереключателей, предусилителей необходимо соблюдать следующие специальные условия:

- преобразователи, вибропереключатели, предусилители должны быть подключены к сертифицированному на соответствие требованиям ТР ТС 012/2011 источнику питания с соответствующей областью применения.

5.2 Свободные концы постоянно подсоединенного кабеля должны подключаться в сертифицированной на соответствие требованиям ТР ТС 012/2011 соединительной коробке или вне взрывоопасной зоны.

Специальные условия применения, обозначенные знаком X, отражены в сопроводительной документации, подлежащей обязательной поставке в комплекте с каждым изделием.

Внесение изменений в конструкцию изделий возможно только по согласованию с ОС ЦСВЭ в соответствии с требованиями ТР ТС 012/2011.

Руководитель (уполномоченное
лицо) органа по сертификации

Эксперт (эксперт-аудитор)
(эксперты (эксперты-аудиторы))

(подпись)

(подпись)

Залогин Александр Сергеевич

(ф.и.о.)

М.П. Рафалович Борис Александрович

(ф.и.о.)

EU Declaration of Conformity PS110
In Accordance with ISO/IEC 17050

Manufacturer: PCB Piezotronics, Inc. 3425 Walden Avenue Depew, New York 14043 USA	Authorized European Representative: PCB Piezotronics Europe GmbH Porschestrasse 20-30 41836 Hückelhoven, Germany
--	---

Certifies that type of equipment: Electronic Vibration Switch(es)

Whose Product Models Include: 685 Series

This declaration is applicable to all Vibration Sensor(s) of the above series which have the CE & (EX) ATEX mark on their data sheets and where those data sheets refer to this declaration of conformity. The data sheets for all model numbers referenced above, which include the CE & (EX) ATEX mark on such data sheets and refer to this Declaration of Conformity are hereby incorporated by reference into this Declaration.

Conform to the following EU Directive(s) when installed per product documentation:	2014/30/EU	EMC Directive
	2014/35/EU	Low Voltage Directive
	2014/34/EU	ATEX Directive
	2011/65/EU w/2015/863/EU	RoHS Directive

Standards to which Conformity is Declared:

Harmonized Standards	EN 61326-1:2013 EN 61326-2-3:2013 EN 61010-1:2010 EN 60079-0:2018 EN 60079-1:2014 EN 63000:2018	Electrical Equipment for Measurement, Control and Laboratory Use- EMC Electrical Equipment for Measurement, Control and Laboratory Use- EMC Safety and EMC requirements for electrical equipment in a laboratory setting. General Explosive Atmosphere Explosive atmospheres. Equipment protection by flameproof enclosures "d" Technical documentation for the assessment of electrical and electronic products with respect to the restriction of hazardous substances
Emissions Test Standards	EN 55011:2009 +A1:2010	Industrial, scientific and medical (ISM) radio frequency equipment- Electromagnetic disturbance characteristics- Limits and methods of Measurement Class B
Other Standards Applied (non-OJEU) Immunity Test Standards	EN 61000-4-2:2001 EN 61000-4-3:2006 EN 61000-4-4:2004 EN 61000-4-5:2005 EN 61000-4-6:2006 EN 61000-4-8:2001 EN 61000-4-11:2004	Electrostatic discharge (ESD) Radiated, radio-frequency, electromagnetic field immunity Electrical fast transient (EFT) / Burst immunity Surge immunity Immunity to RF conducted line disturbances Power frequency magnetic field immunity Voltage Dips, Short Interruptions and Voltage Variations Immunity
Test Reports	EMC Reports Safety Reports	GM29045c GM29046s
EC Type Examination	ATEX Certification	LCIE 10 ATEX 3065 Ex II 2G, Ex d IIB + H2 T4
Notified Body Name		Laboratoire Central des Industries Electriques (0081)
Notified Body's Address		FONTENAY-AUX-ROSES (Head Office) 33 Avenue du Général Leclerc FR- 92260 Fontenay-aux-Roses Tel. : + 33 1 40 95 60 60 Fax : + 33 1 40 95 86 56

I, the undersigned, hereby declare that the equipment specified above conforms to the above Directive(s) Standard(s)

Place: Depew, NY **Date:** 04/04/2022

Signature:



Name:

Carrie Termin

Title:

Regulatory Affairs and Product Certification Specialist