

PCB Piezotronics Inc. claims proprietary rights in the information disclosed hereon. Neither it nor any reproduction thereof will be disclosed to others without the written consent of PCB Piezotronics Inc.

REVISIONS		
REV	DESCRIPTION	DIN
NR	RELEASED TO DRAFTING	47810

68730

6X M6x1 - 6H ∇ .35 [8.9]

\varnothing 1.25 [31.8] BOLT CIRCLE

2X M5 X 50mm SOCKET HEAD CAP SCREWS SUPPLIED

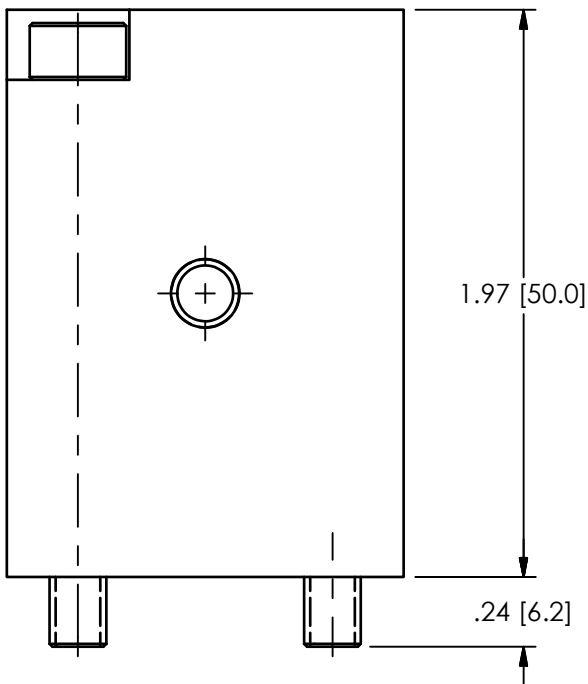
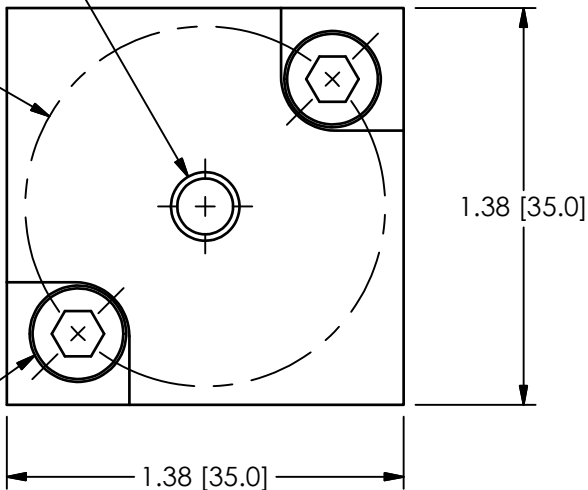

1.) MATERIAL: 303 STAINLESS STEEL

UNLESS OTHERWISE SPECIFIED TOLERANCES ARE:		DRAWN		CHECKED		ENGINEER		 3425 WALDEN AVE. DEPEW, NY 14043 (716) 684-0001 E-MAIL: sales@pcb.com	
DIMENSIONS IN INCHES	DIMENSIONS IN MILLIMETERS [IN BRACKETS]	KRM	2/2/18	KRM	2/2/18	GCD	2/2/18		
DECIMALS XX \pm .03 XXX \pm .010	DECIMALS X \pm 0.8 XX \pm 0.25	TITLE OUTLINE DRAWING TRIAX MOUNTING BLOCK 080M489							CODE IDENT. NO. 52681
ANGLES \pm 2 DEGREES	ANGLES \pm 2 DEGREES								DWG. NO. 68730
FILLETS AND RADII .003 - .005	FILLETS AND RADII 0.07 - 0.13	SCALE: 1.5X		SHEET 1 OF 1					