

PERFORMANCE SPECIFICATION  
 ACCELEROMETER  
 (Model 727-XXX-EE-ZZ)

Document Number	Rev	Date	Entered by	Description of Change	Change Accountable Engineer	ECO
EDVPS727	B	9/11/23	NAD	Updated Endevco Format and Removed Optional Accessories	JAS	54208

### 1.0 DESCRIPTION

The ENDEVCO® Model 727 is a family of rugged undamped piezoresistive accelerometers designed for shock measurements in mobile consumer electronic devices. The highly efficient sensing system of the 727 is sculptured from a single chip of silicon, which includes the inertial mass and strain gages arranged in a four-active-arm Wheatstone bridge circuit. The extremely small size and unique construction of the element allows exceptionally high resonant frequency. On-chip balance resistors provide low zero measured output and low thermal zero drift. The lightweight Model 727 is designed to be adhesively mounted to the test article with minimal mass loading

### 2.0 PERFORMANCE

All specifications assume +75°F (+24°C) and 10Vdc excitation. The following parameters are 100% tested. Calibration data, traceable to NIST, are supplied.

MODEL	Sensitivity			Zero Measurand		Range	Resistance
	[ $\mu$ V/V/g]			Output (ZMO)			
	(min)	(typ)	(max)	(min)	(max)	(input and output)	[ $\Omega$ ]
727-60K	0.15	0.3	0.5	10	10	60 000	650 $\pm$ 300
727-20K	0.5	1	1.5	10	10	20 000	650 $\pm$ 300
727-6K	1.5	3	5	10	10	6 000	650 $\pm$ 300
727-2K	5	10	15	10	10	2 000	650 $\pm$ 300

A specification of  $\mu$ V/V provides a parameter specification that is independent of excitation voltage. Calculate the specification at any excitation voltage by multiplying by the excitation voltage. This applies to any parameter with a 'unit'/V specification.

### 3.0 TYPICAL PERFORMANCE CHARACTERISTICS

The following parameters are established by testing of sample units and are not 100% tested.

MODEL	Resonant Frequency		Mounted
	[kHz]		Frequency Response
	(min)	(typ)	(typ)
727-60K	400	700	100
727-20K	220	350	50
727-6K	120	180	20
727-2K	60	90	10

The sensor chip includes two masses, each with a separate resonant frequency. Both resonances satisfy the specified minimum resonant frequency. If these resonances are excited, the transducer output will exhibit a "beat" frequency.

- |     |   |   |
|-----|---|---|
| 3.1 | ZERO SHIFT DUE TO HALF SINE ACCELERATION CAUSING 200 Mv AT FULL SCALE RANGE | 0.5 mV maximum  |
| 3.2 | OVERRANGE LIMIT   | 1.5X full scale range   |
| 3.3 | AMPLITUDE LINEARITY   | ±2% of reading up to acceleration corresponding to the recommended range. Measurement uncertainties prevent stating this as a specification limit at accelerations above 10 000 g |
| 3.4 | TRANSVERSE SENSITIVITY  | 5% maximum  |
| 3.5 | SENSITIVITY DEVIATION DUE TEMPERATURE                                       | Typical deviation is -1.2% change in sensitivity per +18°F (+10°C) change in case temperature.  |
| 3.6 | THERMAL ZERO SHIFT  | ±10 mV typical, ±50 mV maximum, 32°F to +158°F (0°C to +70°C) relative to +75°F (+24°C)   |

#### 4.0 **ELECTRICAL**

- |     |            |  |
|-----|------------|--|
| 4.1 | EXCITATION | 2 to 12 Vdc (see Para. 9.0 for ordering information) |
|-----|------------|--|

Although this circuit is a simple 4 active-arm Wheatstone bridge, the sensitivity vs. excitation is not perfectly linear due to the self heating of the strain gages. To obtain maximum accuracy from the calibration of the unit at Endevco, the excitation voltage to be used in the application should be specified at time of order.

- |     |  |   |
|-----|--|---|
| 4.2 | INSULATION RESISTANCE                                  | 100 MΩ minimum at 50 Vdc between the sensor (all leads tied together) and cable shield or case. |
| 4.3 | WARM-UP TIME REQUIRED TO MEET THE ABOVE SPECIFICATIONS | 2 minutes maximum, 15 seconds typical   |

#### 5.0 **PHYSICAL**

- |       |                          |   |
|-------|--------------------------|---|
| 5.1   | CASE MATERIAL            | AL 6061-T6, hard anodized   |
| 5.2   | WEIGHT (EXCLUDING CABLE) | 0.01 ounce (0.3 gram) typical   |
| 5.3   | CABLE                    | (4) 36 AWG SPC, braided shield, FEP jacket                            |
| 5.3.1 | CABLE WEIGHT             | 0.04 ounce/foot   |
| 5.4   | IDENTIFICATION           | Endevco sigma and serial number on side of unit; model number on lid. |
| 5.5   | MOUNTING                 | Adhesive, reference IM727   |

#### 6.0 **ENVIRONMENTAL**

- |     |   |  |
|-----|---|--|
| 6.1 | TEMPERATURE<br>Operating:<br>Non-operating: | 32°F to +158°F (0°C to +70°C)<br>-40°F to +185°F (-40°C to +85°C)                  |
| 6.2 | BASE STRAIN SENSITIVITY                     | Typically less than 0.5 mV for 250 microstrain when tested per ISA 37.2, para 6.5. |

**7.0 CALIBRATION DATA SUPPLIED**

(Taken at room temperature at customer-specified voltage)

7.1 SENSITIVITY

Sensitivity per g taken at full-scale range or 5000 g, whichever is smaller.

7.2 ZERO MEASURAND OUTPUT

7.3 INPUT RESISTANCE

7.4 OUTPUT RESISTANCE

**8.0 ACCESSORIES**

8.1 Supplied  
Removal Tool

42894

**9.0 ORDERING INFORMATION**

Model Number Definition:

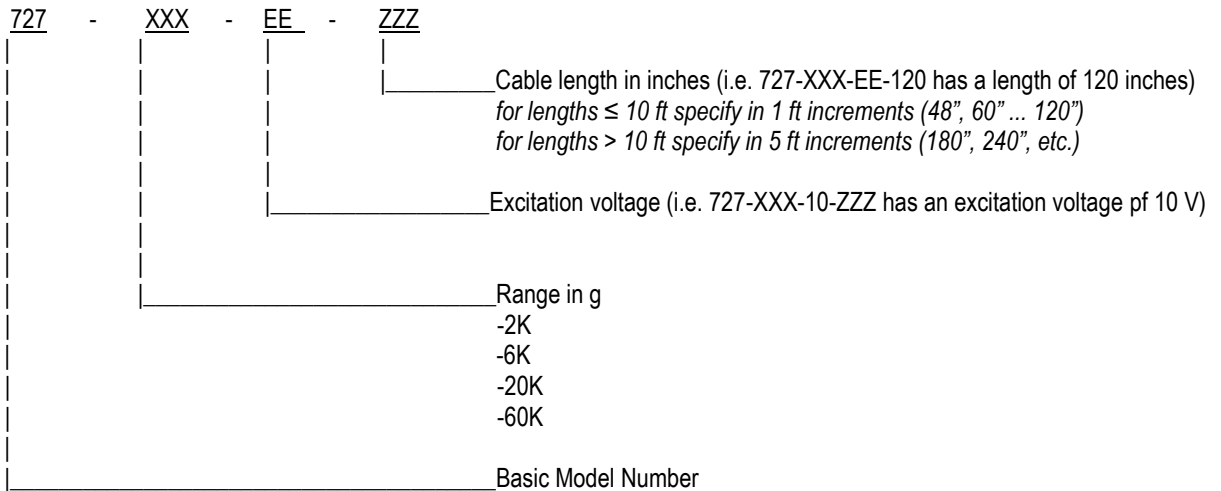

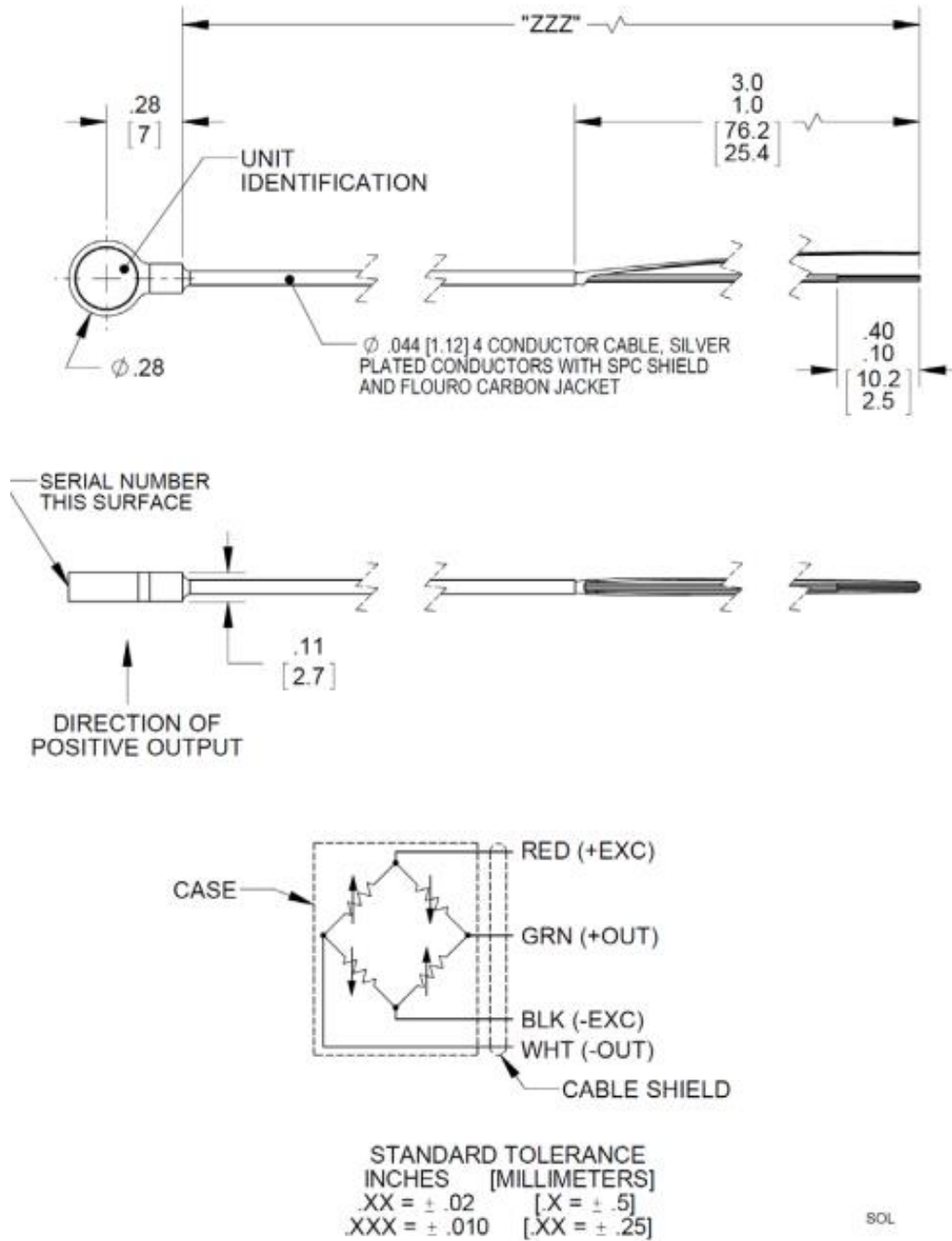

Outline Drawing