

PCB Piezotronics Inc. claims proprietary rights in the information disclosed hereon. Neither it nor any reproduction thereof will be disclosed to others without the written consent of PCB Piezotronics Inc.

78062

REVISIONS		
REV	DESCRIPTION	DIN
NR	RELEASED TO DRAFTING	54063

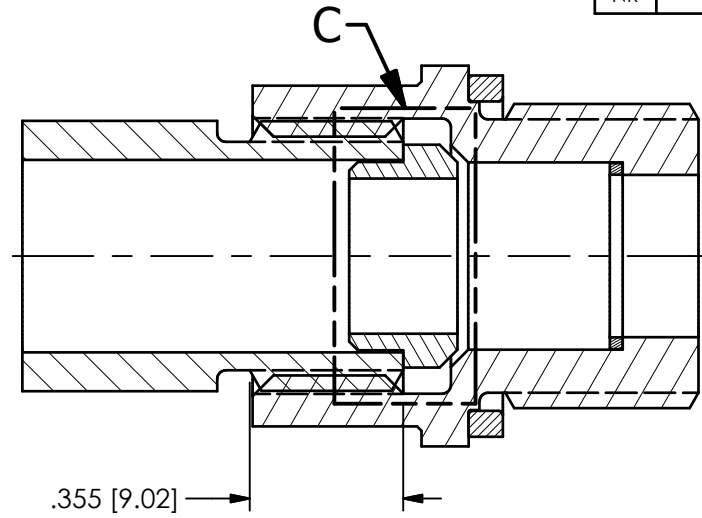
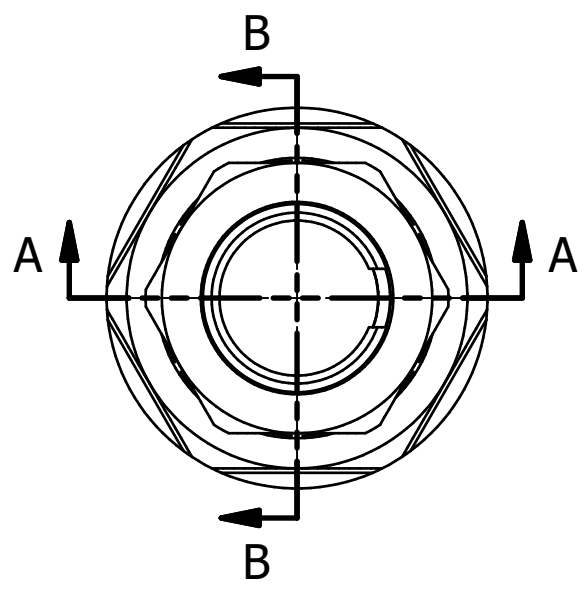

SECTION B-B

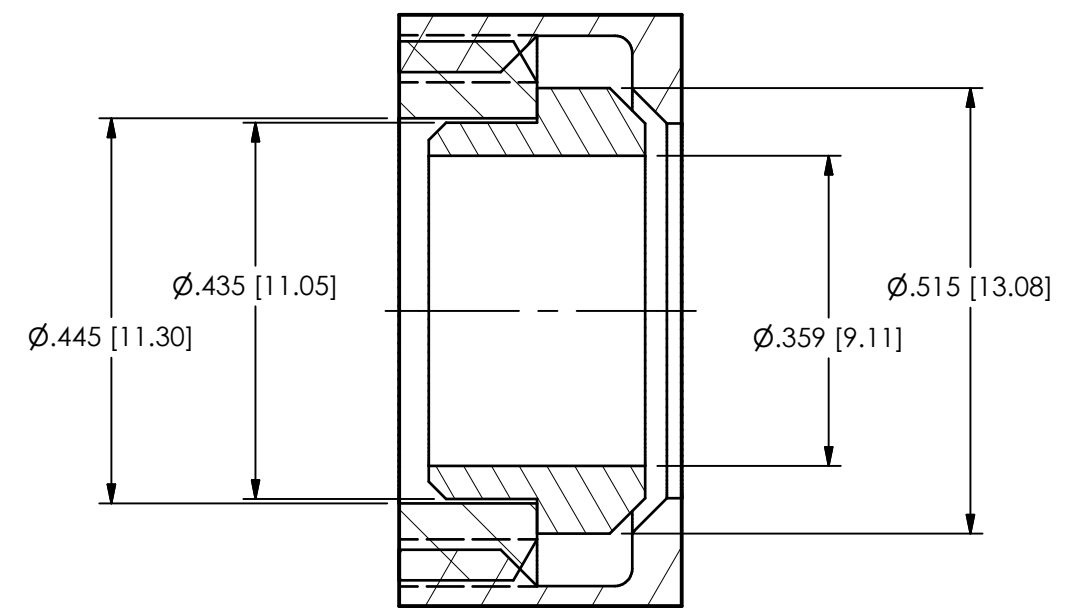

DETAIL C
SCALE 4.5X

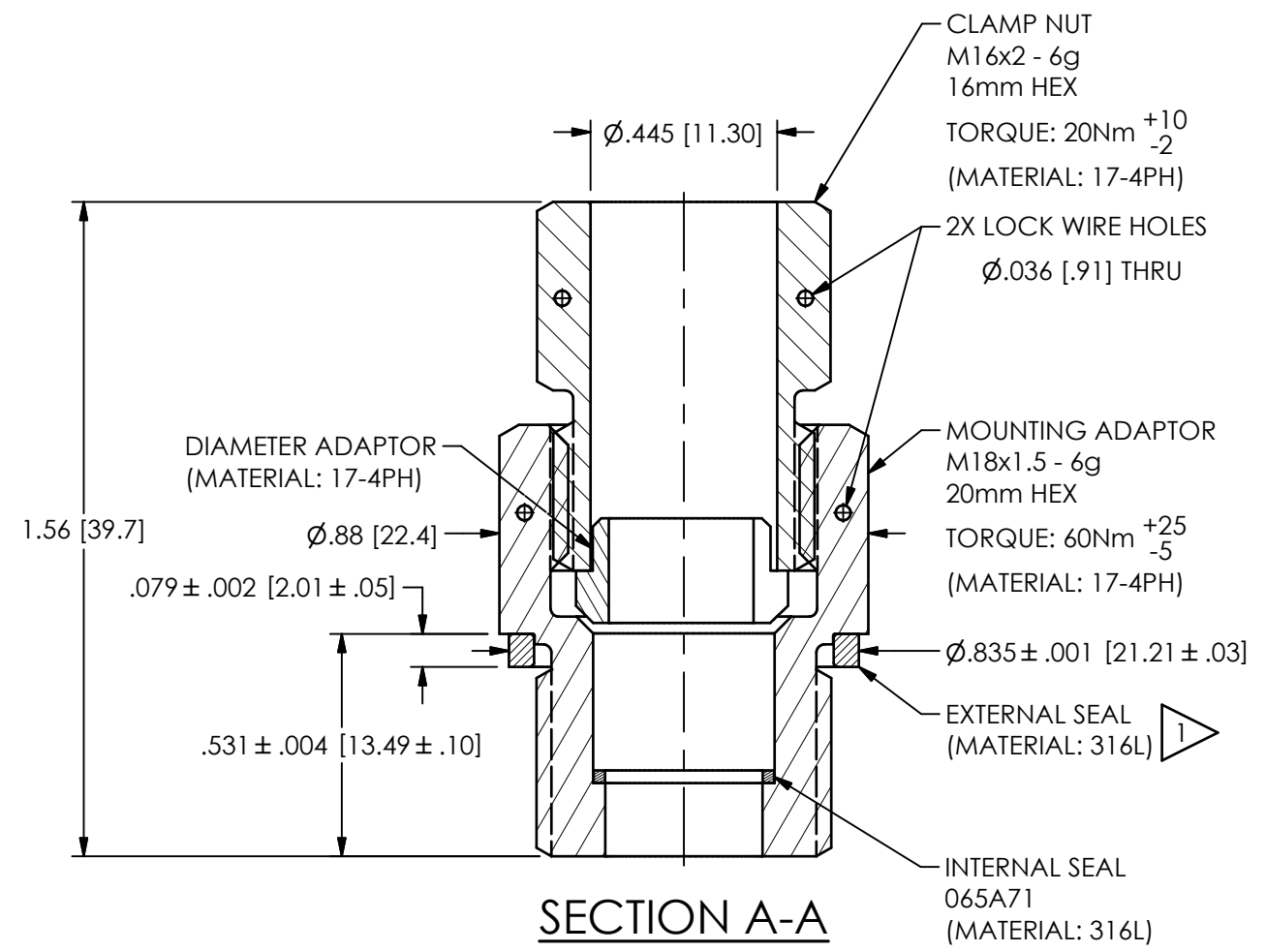

SECTION A-A

1 MATING MACHINE SURFACES TO HAVE A SURFACE FINISH OF Ra 0.8

UNLESS OTHERWISE SPECIFIED TOLERANCES ARE:		DRAWN		CHECKED		ENGINEER	
DIMENSIONS IN INCHES		NJF	07/26/23	JJF	07/26/23	RF	07/26/23
DECIMALS XX ±.03 XXX ±.010		TITLE					
ANGLES ± 2 DEGREES							
DIMENSIONS IN MILLIMETERS (IN BRACKETS)		OUTLINE DRAWING 060A59 SERIES MOUNTING ADAPTOR					
DECIMALS X ± 0.8 XX ± 0.25							
CABLE TOLERANCES IN ENGLISH		PCB PIEZOTRONICS AN AMPHENOL COMPANY 3425 WALDEN AVE. DEPEW, NY 14043 (716) 684-0001 E-MAIL: sales@pcb.com					
CABLE TOLERANCES IN METRIC							
FILLETS AND RADII		CODE IDENT. NO.		DWG. NO.		SCALE: SHEET	
.003 - .005		52681		78062		2.25X 1 OF 1	