

2

1

PCB Piezotronics Inc. claims proprietary rights in the information disclosed hereon. Neither it nor any reproduction thereof will be disclosed to others without the written consent of PCB Piezotronics Inc.

REVISIONS

REV	DESCRIPTION	DIN
NR	RELEASED TO DRAFTING	55566

80144

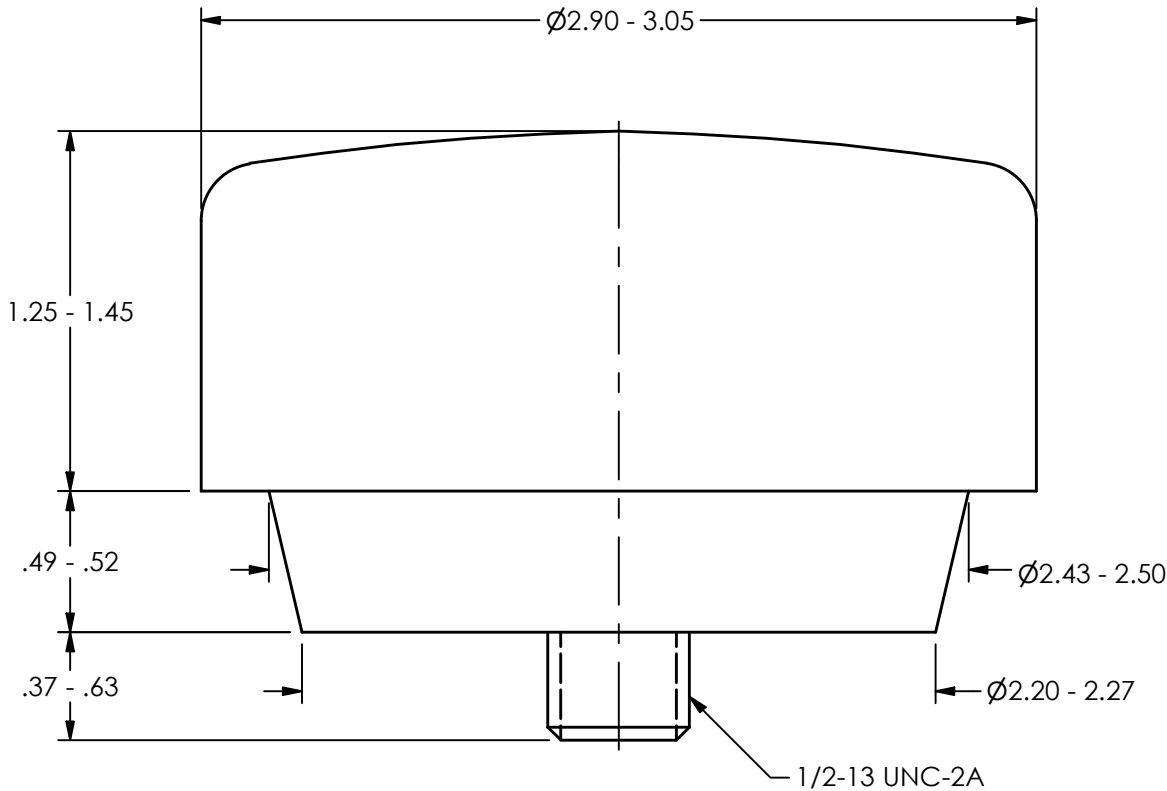

084B32	RED	MEDIUM/HARD
084B31	ORANGE	SOFT
084B30	PINK	SUPER SOFT
MODEL	COLOR	HARDNESS CATEGORY

UNLESS OTHERWISE SPECIFIED TOLERANCES ARE:

DIMENSIONS IN INCHES		DIMENSIONS IN MILLIMETERS [IN BRACKETS]	
DECIMALS XX ±.03		DECIMALS X ± 0.8	
XXX ±.010		XX ± 0.25	
ANGLES ± 2 DEGREES		ANGLES ± 2 DEGREES	
CABLE TOLERANCES IN ENGLISH		CABLE TOLERANCES IN METRIC	
1" ≤ LENGTH < 1'	= +1"/ - 0	2.54cm ≤ LENGTH < 30.5cm	= +2.54cm/ - 0
1' ≤ LENGTH < 5'	= +2"/ - 0	30.5cm ≤ LENGTH < 1.5m	= +5.1cm/ - 0
5' ≤ LENGTH < 100'	= +6"/ - 0	1.5m ≤ LENGTH < 30.5m	= +15.2cm/ - 0
100' ≤ LENGTH	= +1"/ - 0	30.5m ≤ LENGTH	= +30.5cm/ - 0
FILLETS AND RADII	.003 - .005	FILLETS AND RADII	0.07 - 0.13

DRAWN		CHECKED		ENGINEER	
AME	3/6/25	JDM	3/6/25	GCD	3/6/25

TITLE  
**OUTLINE DRAWING  
 3" HAMMER TIP**

**PCB PIEZOTRONICS**  
 AN AMPHENOL COMPANY  
 3425 WALDEN AVE. DEPEW, NY 14043  
 (716) 684-0001 E-MAIL: sales@pcb.com

CODE IDENT. NO. 52681	SIZE A	DWG. NO. 80144
SCALE: 1.5X	SHEET 1 OF 1	

2

1