



**Model 8162-011A**  
**Strain Gage Sensor Signal Condition**  
**Installation and Operating Manual**

**For assistance with the operation of this product,  
contact PCB Piezotronics, Inc.**

**Toll-free: 800-828-8840**  
**24-hour SensorLine: 716-684-0001**  
**Fax: 716-684-0987**  
**E-mail: [info@pcb.com](mailto:info@pcb.com)**  
**Web: [www.pcb.com](http://www.pcb.com)**



## Repair and Maintenance

PCB guarantees Total Customer Satisfaction through its “Lifetime Warranty Plus” on all Platinum Stock Products sold by PCB and through its limited warranties on all other PCB Stock, Standard and Special products. Due to the sophisticated nature of our sensors and associated instrumentation, **field servicing and repair is not recommended and, if attempted, will void the factory warranty.**

Beyond routine calibration and battery replacements where applicable, our products require no user maintenance. Clean electrical connectors, housings, and mounting surfaces with solutions and techniques that will not harm the material of construction. Observe caution when using liquids near devices that are not hermetically sealed. Such devices should only be wiped with a dampened cloth—never saturated or submerged.

In the event that equipment becomes damaged or ceases to operate, our Application Engineers are here to support your troubleshooting efforts 24 hours a day, 7 days a week. Call or email with model and serial number as well as a brief description of the problem.

## Calibration

Routine calibration of sensors and associated instrumentation is necessary to maintain measurement accuracy. We recommend calibrating on an annual basis, after exposure to any extreme environmental influence, or prior to any critical test.

PCB Piezotronics is an ISO-9001 certified company whose calibration services are accredited by A2LA to ISO/IEC 17025, with full traceability to SI through N.I.S.T. In addition to our standard calibration services, we also offer specialized tests, including: sensitivity at elevated or cryogenic temperatures, phase response, extended high or low frequency response, extended range, leak testing, hydrostatic pressure testing, and others. For more information, contact your local PCB Piezotronics distributor, sales representative, or factory customer service representative.

## Returning Equipment

If factory repair is required, our representatives will provide you with a Return Material Authorization (RMA) number, which we use to reference any information you have already provided and expedite the repair process. This number should be clearly marked on the outside of all returned package(s) and on any packing list(s) accompanying the shipment.

## Contact Information

PCB Piezotronics, Inc.  
3425 Walden Ave.  
Depew, NY14043 USA  
Toll-free: (800) 828-8840  
24-hour SensorLine: (716) 684-0001  
General inquiries: [info@pcb.com](mailto:info@pcb.com)  
Repair inquiries: [rma@pcb.com](mailto:rma@pcb.com)

For a complete list of distributors, global offices and sales representatives, visit our website, [www.pcb.com](http://www.pcb.com).

## Safety Considerations

This product is intended for use by qualified personnel who recognize shock hazards and are familiar with the precautions required to avoid injury. While our equipment is designed with user safety in mind, the protection provided by the equipment may be impaired if equipment is used in a manner not specified by this manual.

Discontinue use and contact our 24-Hour Sensorline if:

- Assistance is needed to safely operate equipment
- Damage is visible or suspected
- Equipment fails or malfunctions

For complete equipment ratings, refer to the enclosed specification sheet for your product.

## Definition of Terms and Symbols

The following symbols may be used in this manual:



### **DANGER**

Indicates an immediate hazardous situation, which, if not avoided, may result in death or serious injury.

**CAUTION**

Refers to hazards that could damage the instrument.

**NOTE**

Indicates tips, recommendations and important information. The notes simplify processes and contain additional information on particular operating steps.

**The following symbols may be found on the equipment described in this manual:**



This symbol on the unit indicates that high voltage may be present. Use standard safety precautions to avoid personal contact with this voltage.



This symbol on the unit indicates that the user should refer to the operating instructions located in the manual.



This symbol indicates safety, earth ground.



PCB工业监视和测量设备 - 中国RoHS2公布表

PCB Industrial Monitoring and Measuring Equipment - China RoHS 2 Disclosure Table

部件名称	有害物质					
	铅 (Pb)	汞 (Hg)	镉 (Cd)	六价铬 (Cr(VI))	多溴联苯 (PBB)	多溴二苯醚 (PBDE)
住房	0	0	0	0	0	0
PCB板	X	0	0	0	0	0
电气连接器	0	0	0	0	0	0
压电晶体	X	0	0	0	0	0
环氧	0	0	0	0	0	0
铁氟龙	0	0	0	0	0	0
电子	0	0	0	0	0	0
厚膜基板	0	0	X	0	0	0
电线	0	0	0	0	0	0
电缆	X	0	0	0	0	0
塑料	0	0	0	0	0	0
焊接	X	0	0	0	0	0
铜合金/黄铜	X	0	0	0	0	0
本表格依据 SJ/T 11364 的规定编制。						
0：表示该有害物质在该部件所有均质材料中的含量均在 GB/T 26572 规定的限量要求以下。						
X：表示该有害物质至少在该部件的某一均质材料中的含量超出 GB/T 26572 规定的限量要求。						
铅是欧洲RoHS指令2011/65/ EU附件三和附件四目前由于允许的豁免。						

CHINA RoHS COMPLIANCE

Component Name	Hazardous Substances					
	Lead (Pb)	Mercury (Hg)	Cadmium (Cd)	Chromium VI Compounds (Cr(VI))	Polybrominated Biphenyls (PBB)	Polybrominated Diphenyl Ethers (PBDE)
Housing	O	O	O	O	O	O
PCB Board	X	O	O	O	O	O
Electrical Connectors	O	O	O	O	O	O
Piezoelectric Crystals	X	O	O	O	O	O
Epoxy	O	O	O	O	O	O
Teflon	O	O	O	O	O	O
Electronics	O	O	O	O	O	O
Thick Film Substrate	O	O	X	O	O	O
Wires	O	O	O	O	O	O
Cables	X	O	O	O	O	O
Plastic	O	O	O	O	O	O
Solder	X	O	O	O	O	O
Copper Alloy/Brass	X	O	O	O	O	O

This table is prepared in accordance with the provisions of SJ/T 11364.

O: Indicates that said hazardous substance contained in all of the homogeneous materials for this part is below the limit requirement of GB/T 26572.

X: Indicates that said hazardous substance contained in at least one of the homogeneous materials for this part is above the limit requirement of GB/T 26572.

Lead is present due to allowed exemption in Annex III or Annex IV of the European RoHS Directive 2011/65/EU.

**Table of Contents**

<b>Section</b>	<b>Page</b>
1.0 Description	2
2.0 Power Connections	2
3.0 Transducer Cabling	2
4.0 Analog Outputs	2
5.0 Transducer Excitation	2
6.0 Calibration	3
7.0 Gain Switches	4
8.0 Mounting	4
<b>Figures</b>	
1 - Series 8162 Signal Conditioner	2
2 - Mounting Hole Dimensions	4
3 - Exterior Dimensions	4
4 - Inside View	5
<b>Tables</b>	
1 - Transducer Cabling	2
2 - Gain Switch Positions	4

**1.0 Description**

Series 8162 Strain Gage Signal Conditioners provide conditioned, amplified analog voltage and current output for strain gage based sensors such as load cells and reaction torque sensors. The units operate from 12 to 28 V<sub>DC</sub> power, and deliver ± 5 or ± 10 V and 4 to 20 mA output signals for recording, control, and analysis purposes.



**Figure 1 - Series 8162 Signal Conditioner**

The Series 8162 Signal Conditioners provide a wide strain gage input range from 0.5 to 11 mV/V, and are housed in fire resistant, waterproof NEMA 4X (IP66) enclosures. Standard features include an integral shunt calibration switch with an internal resistor, a two-pole active filter with 100 Hz cut-off, and watertight compression fittings for easy installation.

Typically, Series 8162 Signal Conditioners are configured to operate with a specific transducer during system calibration at the factory. Therefore, internal adjustments are not normally required prior to initial use. However, should adjustments be needed, the following sections outline instructions to configure the conditioner to other specific applications.

**2.0 Power Connection**

The Series 8162 Signal Conditioner is designed to operate on a customer supplied DC power source with a voltage range of 12 to 28 volts. To connect power to the conditioner,

- a. Loosen the four screws on top of the box and remove the lid to expose the internal circuit board.
- b. Insert a power cable through one of compression fittings located on the side of the unit.

- c. Prepare the wire leads of the cable, then insert the input voltage wire into the screw 1 position on terminal J1. Reference Figure 4 for the J1 terminal location. Tighten the screw to fasten the wire in place.
- d. Next, insert the Ground wire into the screw 2 position on terminal J1. Tighten the screw to fasten the wire.

**3.0 Transducer Cabling**

High quality twisted pair shielded cable with four conductors is recommended (such as Belden 8723) for transducer hook up. PCB can supply finished cables for transducers with either a PT02E-10-6P or PC04E-10-6P receptacle if desired.

To connect the transducer to the conditioner, insert the interconnect cable through a compression fitting, then screw attach to terminal J2 per the arrangement outlined in Table 1 below.

Table 1 – Transducer Cabling	
+Signal (Green)	Screw 1
-Signal (White)	Screw 2
-Excitation (Black)	Screw 3
+Excitation (Red)	Screw 4

**4.0 Analog Outputs**

Two analog outputs are available on the 8162 Series Signal Conditioner. The first is a voltage output that is jumper selectable to either ±5 or ±10 volts. The desired voltage output is set by the position of the P2 Jumper. Jumping pins 1 and 2 will set the conditioner to ±10 V<sub>OUT</sub>. Jumping pins 2 and 3 will set the conditioner to ±5 V<sub>OUT</sub>. Adjust Zero Balance and Span by using the R23, R29, and R22 potentiometers on the conditioner’s internal circuit board. Refer to Figure 4. Note that Zero Balance has both a coarse and fine adjustment.

A 4 to 20 mA current output is the second available output. The current output is adjusted using the R5 and R20 potentiometers. Reference Figure 4 for exact locations of the potentiometers.

Connecting output instrumentation to the signal conditioner is accomplished by attaching an interconnect cable to terminal J3 on the conditioner’s internal circuit board. Voltage output is fastened to screw 4; current output is attached to screw 1. Ground leads may be attached to either screw 2 or 3.

**5.0 Transducer Excitation**

Either 5-volt or 10-volt bridge excitation can be selected. In general, 5-volt excitation is used with 120 $\Omega$  transducers, and the 10-volt excitation is used with 350 $\Omega$  and 700 $\Omega$  transducers.

Excitation voltage is set by the position of the P1 Jumper. See Figure 4. Jumping pins 1 and 2 will set the conditioner to 10 V<sub>EXC</sub>. Jumping pins 2 and 3 will set the conditioner to 5 V<sub>EXC</sub>.

## 6.0 Calibration

The Series 8162 can be calibrated using (2) different methods. The first method uses actual or simulated Zero and Full Scale (FS) inputs. Actual inputs may come from a strain gage transducer loaded with calibrated weights. Simulated inputs may come from a strain gage bridge simulator.

The second method utilizes an R<sub>CAL</sub> resistor to simulate a load on a strain gage bridge. The R<sub>CAL</sub> resistor, located in the R12 position in Figure 4, is shunted across one arm of the strain gage bridge when the R<sub>CAL</sub> Switch (SW1) is depressed. The shunt produces an imbalance equivalent to that of a particular value of mechanical input. If this *Equivalent Input* value is accurately known, it can be used as a reference point for shunt calibration of the system. Upon completion of installation of the transducer and its associated cabling, the user can:

- a. Perform an overall deadweight calibration using a precisely known value of mechanical input. The calibration can then be transferred to the installed calibration resistor for convenience in checking later.
- b. Replace the installed calibration resistor with one supplied by the transducer manufacturer, or an equivalent resistance value, to achieve a precisely known equivalent input, allowing the instrument sensitivity to be adjusted correctly.
- c. A 30K ohm resistor is installed at the factory and is used during final checkout of the instrument. It is replaced with a more proper value resistor when calibrated with a specific transducer to produce a more accurate shunt value. The resistor is mounted internally on terminal R12 located on the printed circuit board in the instrument. See Figure 4. It can be reached by removing the cover.

*Note: Soldering is not required to remove or install the shunt calibration resistor. When an amplifier is purchased with a specific sensor as a system, PCB will install the proper value shunt resistor in the amplifier.*

### R<sub>CAL</sub> Polarity (+R<sub>CAL</sub> / -R<sub>CAL</sub>)

The default R<sub>CAL</sub> polarity setting of the Series 8162 Signal Conditioner is positive (+). Depending on the particular sensor being calibrated with the conditioner, +R<sub>CAL</sub> and/or -R<sub>CAL</sub> data is provided on the calibration certificate.

The polarity of the R<sub>CAL</sub> may be switched by changing the solder jumper position on the R<sub>CAL</sub> solder tabs located on the internal circuit board of the conditioner. See Figure 4 for the R<sub>CAL</sub> solder tab locations. Solder applied to jumper 1 will yield a +R<sub>CAL</sub>, solder applied to jumper 2 will yield a -R<sub>CAL</sub>.



**7.0 Gain Switch**

Table 2 illustrates the proper Gain switch settings on switch block SW2 (shown in Figure 4) based on the input signal from the sensor with which it is used. Set each of the four switches to either 1 (ON) or 0 (OFF) according to the sensor’s excitation voltage and sensitivity.

Table 2 – Switch Positions for Input Signal Range Adjustment						
Sensitivity (mV/V) Vexc = 5 VDC	Sensitivity (mV/V) Vexc = 10 VDC	SW2 Settings				SW2 1 = SW “ON”
		1	2	3	4	
7.0 to 11.0	3.5 to 5.5	0	0	0	1	
4.6 to 7.0	2.3 to 3.5	0	0	1	0	
3.0 to 4.6	1.5 to 2.3	0	1	0	0	
2.0 to 3.0	1.0 to 1.5	1	0	0	0	
1.5 to 2.0	0.75 to 1.0	1	0	1	0	
1.0 to 1.5	0.50 to 0.75	1	1	0	1	
0.9 to 1.0	0.45 to 0.50	1	1	1	1	

**8.0 Mounting**

To mount the Series 8162 signal conditioner, reference the hole patterns in Figure 2 for specific dimensions. Figure 3 illustrates the exterior dimensions of the conditioner. Dimensions are expressed in inches (millimeters).

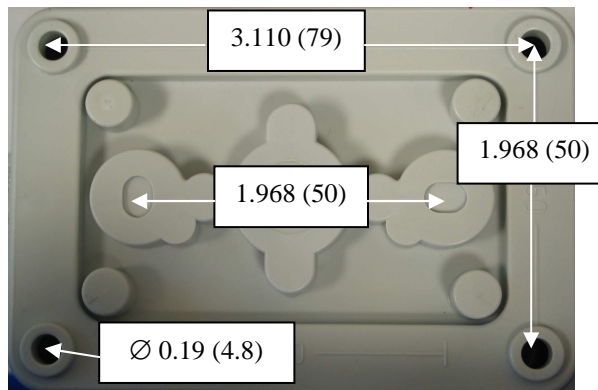

**Figure 2**

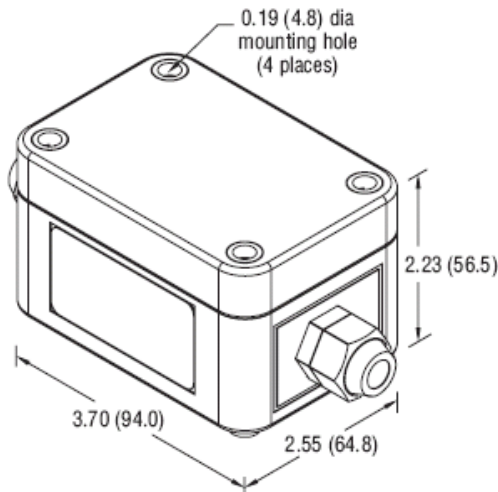

**Figure 3**

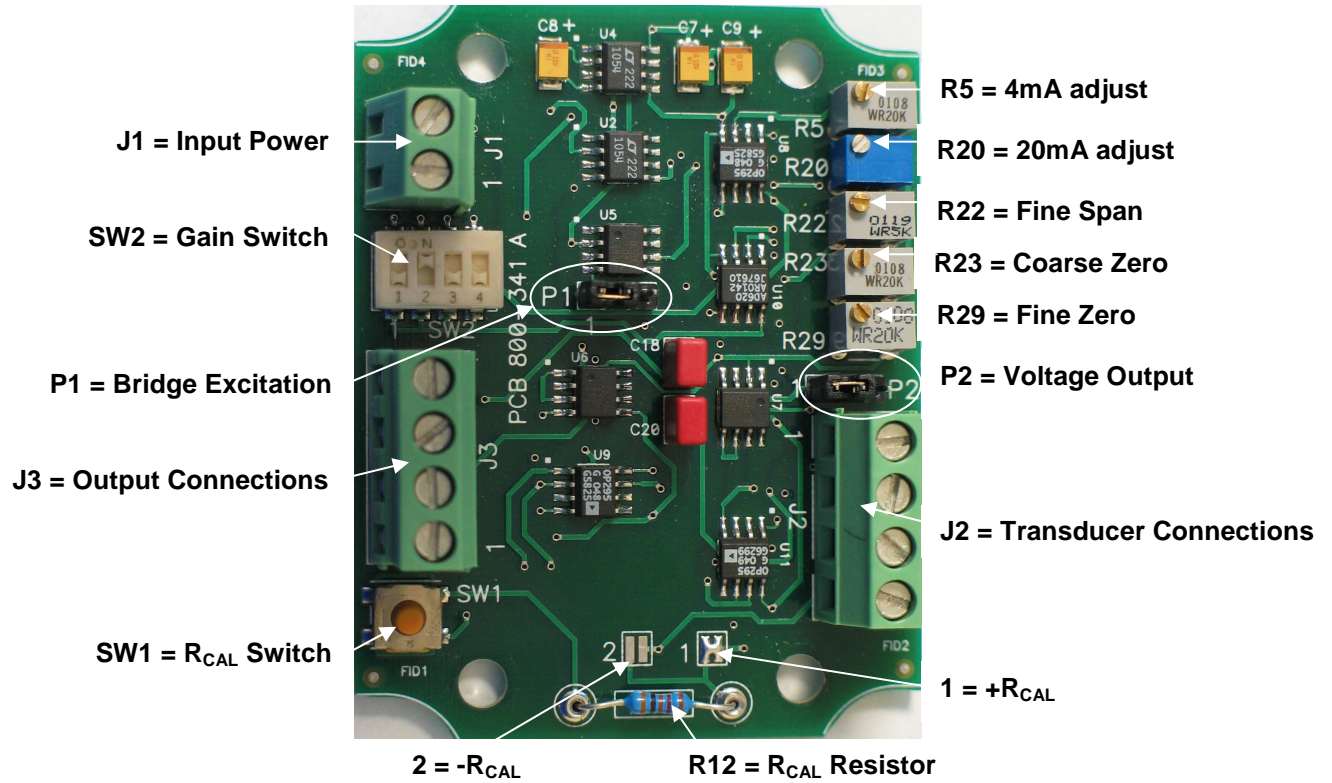



Figure 4 - Inside View

Model Number <b>8162-011A</b>	<b>STRAIN GAGE SENSOR SIGNAL CONDITION</b>			Revision: B ECN #: 41446					
<b>Performance</b> Electrical Filter Cutoff Frequency Frequency Range Input Signal(sensor sensitivity) <b>Environmental</b> Enclosure Rating Excitation Current Temperature Range <b>Electrical</b> Offset Voltage(@min. gain) Offset Voltage(@max.gain) Excitation Voltage Output Voltage Output Current Power Required <b>Physical</b> Size (Length x Height x Width) Electrical Connector(input/output)	<u>ENGLISH</u> 100 Hz 0 to 1000 Hz 0.5 to 11 mV/V NEMA 4X 60 mA +32 to +158 °F ± 50% of F.S. ± 70% of F.S. 10 VDC ± 10 VDC 4 to 20 mA 12 to 28 Vdc 2.23 in x 3.70 in x 2.55 in screw terminal	<u>SI</u> 100 Hz 0 to 1000 Hz 0.5 to 11 mV/V IP66. 60 mA 0 to +70 °C ± 50% of F.S. ± 70% of F.S. 10 VDC ± 10 VDC 4 to 20 mA 12 to 28 Vdc 56.6 mm x 94.0 mm x 64.8 mm screw terminal	[2] [3] [1] [1]	<b>OPTIONAL VERSIONS</b> Optional versions have identical specifications and accessories as listed for the standard model except where noted below. More than one option may be used.					
<b>NOTES:</b> [1] Factory Adjustable [2] Filtered via 2-pole active filter. [3] User Adjustable.									
<table border="1" style="width: 100%; border-collapse: collapse;"> <tr> <td style="width: 20%;">Entered: AP</td> <td style="width: 20%;">Engineer: JSD</td> <td style="width: 20%;">Sales: KWW</td> <td style="width: 20%;">Approved: DA</td> <td style="width: 20%;">Spec Number:</td> </tr> </table>					Entered: AP	Engineer: JSD	Sales: KWW	Approved: DA	Spec Number:
Entered: AP	Engineer: JSD	Sales: KWW	Approved: DA	Spec Number:					
<table border="1" style="width: 100%; border-collapse: collapse;"> <tr> <td style="width: 20%;">Date: 6/13/2013</td> <td style="width: 20%;">Date: 6/13/2013</td> <td style="width: 20%;">Date: 6/13/2013</td> <td style="width: 20%;">Date: 6/13/2013</td> <td style="width: 20%; text-align: center;"><b>23725</b></td> </tr> </table>					Date: 6/13/2013	Date: 6/13/2013	Date: 6/13/2013	Date: 6/13/2013	<b>23725</b>
Date: 6/13/2013	Date: 6/13/2013	Date: 6/13/2013	Date: 6/13/2013	<b>23725</b>					
<p> <i>All specifications are at room temperature unless otherwise specified.            In the interest of constant product improvement, we reserve the right to change specifications without notice.</i> </p> <p>ICP® is a registered trademark of PCB Group, Inc.</p> <div style="text-align: right; padding-right: 50px;"> <p> <b>PCB Load &amp; Torque, Inc.</b>  <b>24350 Indoplex Circle</b>  <b>Farmington Hills, MI 48335</b>  <b>UNITED STATES</b>  <b>Phone: 866-684-7107</b>  <b>Fax: 716-684-0987</b>  <b>E-Mail: <a href="mailto:ltinfo@pcbloadtorque.com">ltinfo@pcbloadtorque.com</a></b>  <b>Web site: <a href="http://www.pcbloadtorque.com">http://www.pcbloadtorque.com</a></b> </p>  </div>									

PCB Load & Torque Inc. claims proprietary rights in the information disclosed hereon. Neither it nor any reproduction thereof will be disclosed to others without the written consent of PCB Load and Torque Inc.

27193

REVISIONS

REV	DESCRIPTION	ECO
A	UPDATED TO PCB L&T - 05.24.13, PTE	41446

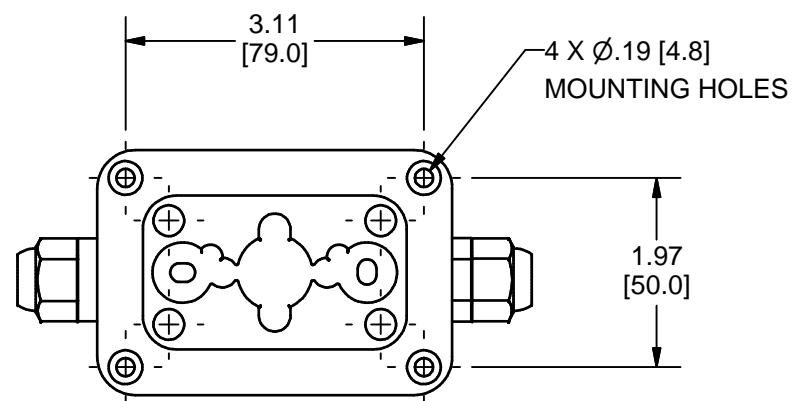
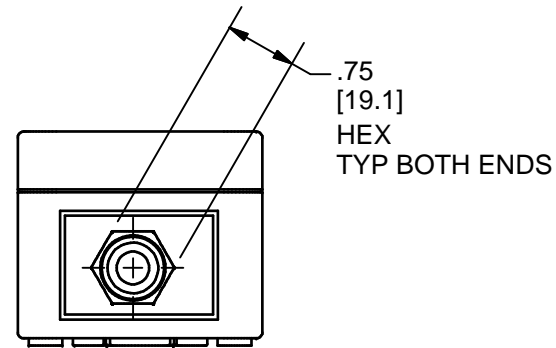
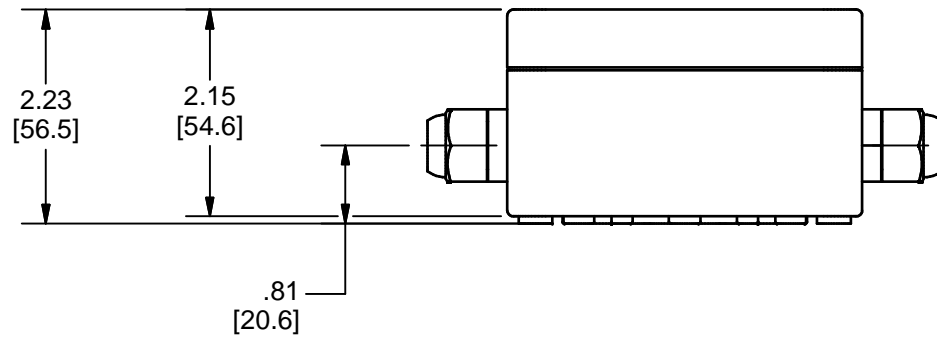
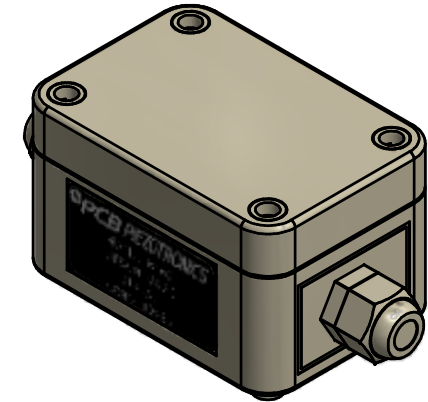
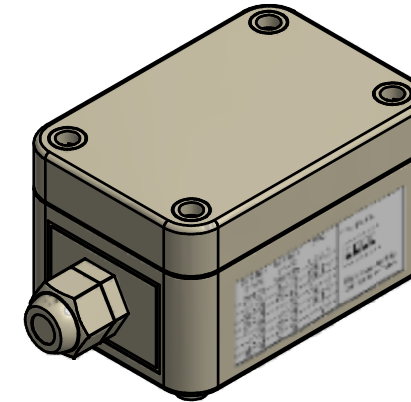
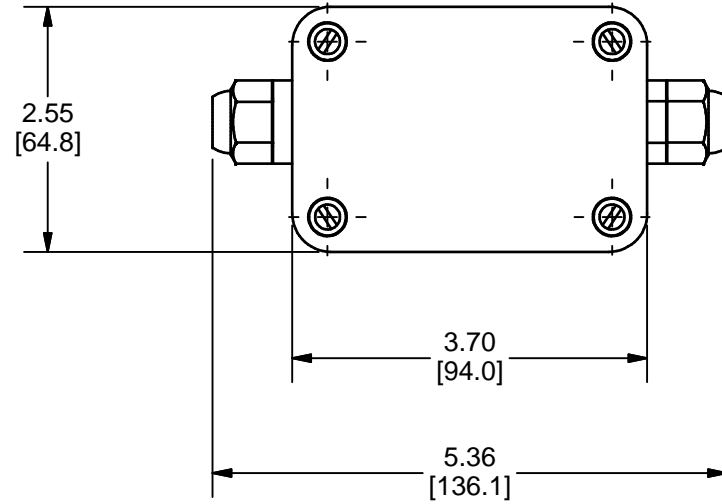

UNLESS OTHERWISE SPECIFIED TOLERANCES ARE:		DRAWN		CHECKED		ENGINEER		 24350 Indoplex Circle, Farmington Hills, MI 48335 (716) 684-0001 E-MAIL: linfo@pcbloadtorque.com DWG. NO. <b>27193</b> SCALE: FULL SHEET 1 OF 1
DIMENSIONS IN INCHES	DIMENSIONS IN MILLIMETERS [IN BRACKETS]	PTE	05.24.13	SAC	05.24.13	SAC	05.24.13	
DECIMALS XX ±.01 XXX ±.005	DECIMALS X ±.3 XX ±.13	TITLE OUTLINE DRAWING MODEL 8162 SIGNAL CONDITIONER						
ANGLES ± .5 DEGREES	ANGLES ± .5 DEGREES							
FILLETS AND RADII .015 MAX	FILLETS AND RADII 0.38 MAX							