

PIEZORESISTIVE
PRESSURE TRANSDUCERS
**INSTRUCTION
MANUAL**

ENDEVCO

San Juan Capistrano, California, U.S.A.



IM8500
REVISION B
February 24, 1997

**ENDEVCO PR PRESSURE TRANSDUCERS
INSTRUCTION MANUAL**

TABLE OF CONTENTS

<u>SECTION 1: INTRODUCTION</u>	<u>PAGE</u>
1. INTRODUCTION	1-1
2. PURPOSE	1-1
3. GENERAL APPLICATION	1-1
4. GENERAL CAUTIONS	1-2
5. IDENTIFICATION	1-2
<u>SECTION 2: THEORY OF OPERATION</u>	
1. THEORY OF OPERATION	2-1
2. PR PRESSURE TRANSDUCERS	2-1
3. MICROPHONES	2-2
4. SENSING ELEMENTS	2-2
5. SENSING BRIDGE	2-3
6. TRANSDUCER DESIGN	2-5
<u>SECTION 3: PERFORMANCE CHARACTERISTICS</u>	
1. PERFORMANCE CHARACTERISTICS	3-1
2. RANGE	3-1
3. SENSITIVITY	3-1
4. COMBINED NON-LINEARITY, NON-REPEATABILITY, HYSTERESIS	3-1
5. NON-LINEARITY, INDEPENDENT	3-1
6. NON-REPEATABILITY	3-3
7. PRESSURE HYSTERESIS	3-3
8. ZERO MEASURAND OUTPUT (ZMO)	3-4
9. ZERO SHIFT	3-4
10. THERMAL SENSITIVITY SHIFT AND THERMAL ZERO SHIFT	3-4
11. RESONANT FREQUENCY	3-6
12. RISE AND RESPONSE TIME	3-7
13. THERMAL TRANSIENT RESPONSE	3-7
14. PHOTO FLASH RESPONSE	3-9
15. ACCELERATION SENSITIVITY	3-11
16. BURST PRESSURE	3-11
17. FULL SCALE OUTPUT	3-11

**ENDEVCO PR PRESSURE TRANSDUCERS
INSTRUCTION MANUAL**

<u>SECTION 3: PERFORMANCE CHARACTERISTICS - (continued)</u>	<u>PAGE</u>
18. SUPPLY VOLTAGE OR EXCITATION	3-11
19. POLARITY	3-12
20. INPUT/OUTPUT RESISTANCE	3-12
21. ISOLATION RESISTANCE	3-12
<u>SECTION 4: ENVIRONMENTAL</u>	
1. TEMPERATURE	4-1
2. ACCELERATION, SHOCK, AND VIBRATION	4-1
3. RF AND MAGNETIC FIELDS	4-1
4. SEALING AND HERMETICITY	4-1
5. MEDIA	4-2
6. NUCLEAR RADIATION	4-2
<u>SECTION 5: APPLICATION INFORMATION</u>	
1. CONNECTION DIAGRAMS	5-1
2. MOUNTING TECHNIQUES	5-1
3. INSULATION	5-4
4. CABLING	5-4
5. LOADING EFFECTS	5-5
6. EFFECT OF CABLE ON SENSITIVITY	5-6
7. BALANCING ZERO MEASURAND OUTPUT	5-7
8. MEASUREMENT OF DYNAMIC PRESSURES	5-7
<u>SECTION 6: ELECTRONICS</u>	
1. DC POWER SUPPLIES	6-1
2. EXTERNAL SENSING	6-2
3. SIGNAL CONDITIONING	6-2
4. AMPLIFIERS	6-2
5. SYSTEMS	6-3
<u>SECTION 7: CALIBRATION</u>	
1. INTRODUCTION	7-1
2. STATIC CALIBRATIONS	7-1
3. DYNAMIC CALIBRATIONS	7-1

**ENDEVCO PR PRESSURE TRANSDUCERS
INSTRUCTION MANUAL**

<u>SECTION 8: CHECK LIST</u>	<u>PAGE</u>
1. INTRODUCTION	8-1
2. MEASUREMENT SYSTEM INSTALLATION CHECKLIST	8-1
<u>SECTION 9: MAINTENANCE AND WARRANTY</u>	
1. RECEIVING INSPECTION AND TROUBLE SHOOTING	9-1
2. TRANSDUCER MAINTENANCE	9-1
3. RECALIBRATION	9-2
4. CABLE MAINTENANCE	9-2
5. WARRANTY	9-2
6. RETURN OF EQUIPMENT	9-2
<u>APPENDIX A: GLOSSARY</u>	
1. GLOSSARY	A-1
<u>APPENDIX B: PRESSURE CONVERSION CHART</u>	
1. PRESSURE CONVERSION CHART	B-1
<u>LIST OF ILLUSTRATIONS</u>	
2-1 DIFFUSED, ETCH-CONTOURED PRESSURE SENSOR	2-2
2-2 DIFFUSED, STRAIN GAGE	2-3
2-3 PRESSURE DIAPHRAGM	2-4
2-4 CUT-AWAY SECTION THROUGH NOTCHES AND ISLANDS	2-4
2-5 SCHEMATIC DIAGRAM FOR 4-ARM BRIDGE	2-4
2-6 CUT-AWAY VIEW OF TYPICAL PRESSURE TRANSDUCER	2-5
3-1 TYPICAL INPUT TO OUTPUT CURVE	3-2
3-2 TYPICAL INDEPENDENT LINEARITY CURVE	3-3
3-3 TRANSDUCER REPEATABILITY	3-3
3-4 TRANSDUCER HYSTERESIS	3-3
3-5 TYPICAL 8510 SENSITIVITY VS. TEMPERATURE	3-5
3-6 TYPICAL 8510 ZERO SHIFT VS. TEMPERATURE	3-6
3-7 RELATIVE FREQUENCY RESPONSE	3-6
3-8 TYPICAL 8510 TEMPERATURE TRANSIENT EFFECT	3-8
3-9 TYPICAL PR ZERO OUTPUT CHANGE FROM TEMPERATURE TRANSIENT	3-9

**ENDEVCO PR PRESSURE TRANSDUCERS
INSTRUCTION MANUAL**

<u>LIST OF ILLUSTRATIONS - (continued)</u>	<u>PAGE</u>
3-10 TYPICAL PR TRANSDUCER CONFIGURATIONS	3-10
3-11 ZERO CHANGE WITH INPUT VOLTAGE CHANGE	3-12
3-12 SENSITIVITY CHANGE WITH INPUT VOLTAGE CHANGE	3-12
5-1 LOW PROFILE PR TRANSDUCER	5-2
5-2 MOUNTING METHODS FOR LOW PROFILE PR TRANSDUCER	5-3
5-3 TYPICAL BASE STRAIN SENSITIVITY	5-4
5-4 SCHEMATIC DIAGRAM OF LOADING EFFECTS	5-5
5-5 SCHEMATIC DIAGRAM OF SIMPLIFIED CIRCUIT WITH LONG CABLE	5-6
5-6 ZERO OUTPUT NETWORK FOR FULL-BRIDGE TRANSDUCER	5-7
5-7 ORGAN PIPE RESONANCE	5-8
5-8 CAVITY RESONANCES-1	5-9
5-9 CAVITY RESONANCES-2	5-9
5-10 TRANSMITTING TUBE CONNECTED TO CAVITY	5-9
5-11 ACOUSTIC LIMITATIONS OF A PRESSURE PROBE	5-10
6-1 TYPICAL GROUND LOOP POTENTIAL	6-4
7-1 PRESSURE SHOCK TUBE	7-2

ENDEVCO PR PRESSURE TRANSDUCERS INSTRUCTION MANUAL

SECTION 1: INTRODUCTION

1. INTRODUCTION

A piezoresistive pressure transducer is a transducer whose electrical output is proportional to the pressure on its sensing surface. Although its application is similar to that of a strain-gage transducer, the piezoresistive transducer offers the advantages of lighter weight, smaller size, higher output, and higher frequency response when compared to other types of transducers.

Unlike the piezoelectric transducer, the piezoresistive is useful for measuring steady-state or static pressures as well as dynamic pressures. The zero frequency response is essential in making accurate long-duration, transient measurements.

With their inherently high gage factors, 10 to over 100 times that of the conventional wire gages, piezoresistive type transducers provide a relatively large output signal. Because of their low output impedance, they can operate directly into oscilloscopes, digital voltmeters, tape recorders, and computers, without intervening electronics or amplification.

The ENDEVCO® Model 8500 Diffused Piezoresistive Pressure Transducers are a family of Pressure Transducers consistent with Endevco's tradition of producing high quality instruments. In addition to high quality and high performance, these transducers provide a high degree of miniaturization. One of the most popular versions of the product family is cased in a 10-32 UNF threaded housing (5 mm diameter). The active area of the pressure sensing surface, which is made of silicon, is only 0.08 in (2 mm) in diameter. Key to the performance and ruggedness is the unique sensor design which incorporates a four-arm Wheatstone bridge diffused into the silicon chip. Instead of a simple flat diaphragm Endevco has developed a special shaped silicon chip which concentrates the stress at the location of the resistive elements. This results in a higher sensitivity for a given resonant frequency as well as a substantial increase in ruggedness. Included within the small transducers are bridge balancing and temperature compensating elements to optimize performance. This is accomplished through the use of hybrid circuit fabrication techniques.

2. PURPOSE

The purpose of this manual is to describe the theory of operation, application, and installation of Endevco piezoresistive pressure transducers.

Data Sheet terminology is defined and discussed. Selection and Installation tips are provided, as well as a brief discussion of some common problems encountered in making dynamic pressure measurements. A glossary and pressure unit conversion chart are provided.

3. GENERAL APPLICATIONS

Manufacturers of sensors and transducers are continuing their efforts to refine designs and improve performance. Most of these efforts are reflected in advances in the semiconductor technology associated with integrated circuits. Some of these same processes are utilized in Endevco's line of miniature pressure transducers. The heart of these products is the novel micro-machined silicon diaphragm, which has an active four-arm Wheatstone bridge diffused into its single crystal structure. See Endevco Technical Paper 277 for more details.

These silicon diaphragms are extremely small in size and are packaged in a variety of configurations including threaded and cylindrical housings, and flat cases.

Most conventional silicon diaphragm transducers have initially been thought of as dynamic-only devices. Only recently have they begun to gain acceptance as a static measuring device. Typical static errors (non-linearity, hysteresis and non-repeatability) are 0.25% of full scale output and below. With these accuracies, silicon diaphragm devices have begun to find applications where they can be used to advantage to measure static pressures.

ENDEVCO PR PRESSURE TRANSDUCERS INSTRUCTION MANUAL

Because of the extremely small size of the sensing element, the solid state sensors offer more flexibility in packaging than any other technology. Typical aerospace applications are model and full-scale wind tunnel tests, flight tests, brake and hydraulic system tests, jet engine fuel system tests, and other measurements of turbulent flow. Automotive applications include engine, air and fuel systems, brake systems, automatic transmissions, and general laboratory pressure measurements.

4. GENERAL CAUTIONS

A. LOADING

Do not subject the silicon diaphragm to concentrated loading. It is designed for distributed pressure loading. Point or concentrated loading, such as pencil tips, tweezers, or other sharp objects pressed against the diaphragm WILL BREAK the diaphragm.

B. CABLE ATTACHMENT

Do not subject the cable attachment to tensile load. Cable attachments of most models will withstand up to 10 pounds pull without damage, but cables should be secured to prevent whipping and excessive loading of the cable attachment.

C. SEALING

Do not immerse the back end in liquid or conductive gas. The cable and vent tube entries into the case (when present) are epoxy sealed. The vent tube leads directly into the case cavity and to the back side of the diaphragm. Components and connections inside the case are Parylene coated for protection against humidity, but they will be damaged by immersion in conductive media.

For best protection, seal the case, cable entry, and cable with RTV or similar sealant. BE CAREFUL NOT TO PLUG THE VENT TUBE on gage and differential units.

D. CABLE PROTECTION

Protect the cable from sharp objects, since the silicone jacket is easily cut.

5. IDENTIFICATION

Endevco pressure transducers are identified by a four-digit basic model number (i.e. 8510) signifying the transducer type and physical configuration. A letter following the model number indicates the applicable revision level (i.e. 8510-B, 8507-C). The pressure range in pounds per square inch is indicated by a dash-number following the basic model number. Minor variations, configuration controlled models, etc. are designated by an M-number suffix.

ENDEVCO PR PRESSURE TRANSDUCERS INSTRUCTION MANUAL

SECTION 2: THEORY OF OPERATION

1. THEORY OF OPERATION

Pressure is defined as force-per-unit area. The most common measurements are made in gaseous or liquid media. All pressure gauges and transducers use a force-summing device to convert the pressure into a stress or displacement proportional to the pressure. In transducers, the stress or displacement is then applied to an electrical transduction element to generate the required signal. Endevco piezoresistive pressure transducers combine the force-summing device and the transduction element into a sculptured diffused silicon diaphragm. The high stiffness, small size, and low mass of the transduction system provide an ideal combination of wide frequency response, high sensitivity, and immunity to acceleration and strain inputs.

2. PIEZORESISTIVE PRESSURE TRANSDUCERS

A. GENERAL DESCRIPTION

A pressure transducer is a transducer that produces an electrical output proportional to the pressure applied. The frequency of pressure fluctuation should be lower than the resonant frequency of the transducer, and the electrical output is essentially independent of frequency below one-fifth the resonant frequency (flat frequency response).

When pressure is applied, the force on the sensing element due to the pressure results in a deformation of the sensing element. This deformation changes the resistance of the element and the electrical output of the transducer. In a well-designed transducer, the deformation and electrical output are directly proportional to pressure over a wide range of frequencies.

The sensing elements and constraining parts in silicon diaphragm pressure transducers possess such a small amount of damping due to internal friction that it may be disregarded. Significant amounts of damping may be introduced by the medium being measured.

Endevco pressure transducers employ a fully active Wheatstone Bridge, consisting of four piezoresistive gages atomically diffused into a sculptured silicon diaphragm (See Figure 2-1). The silicon integrated chip is itself the diaphragm. Applied pressure presents a distributed load to the diaphragm, which in turn provides bending stresses and resultant strains to which the strain gages react. This stress creates a strain proportional to the applied pressure, which results in a bridge unbalance. With an applied voltage, this unbalance produces a millivolt deviation at the bridge output, which is proportional to the net difference in pressure acting upon the diaphragm.

B. REFERENCE PRESSURE

Pressure transducers are available with three reference pressure options: Gauge, psig; Absolute, psia; and Differential, psid.

Gauge-PSIG: Pressure is referenced to ambient pressure through an open reference tube.

Absolute-PSIA: Pressure is referenced to absolute zero pressure by sealing a vacuum within the transducer cavity (true absolute).

ENDEVCO PR PRESSURE TRANSDUCERS INSTRUCTION MANUAL

Differential-PSID: Pressure is referenced to a second pressure source through the reference tube. For the reference port source, differential units must use a non-conductive non-corrosive medium, which will not affect epoxy. Water and media containing water are not permissible. The reference port is the LOW PRESSURE side in all differential measurements. Differential transducers are designed for specified maximum line pressure. Maximum reference pressure, and maximum case pressure are specified on the data sheets.

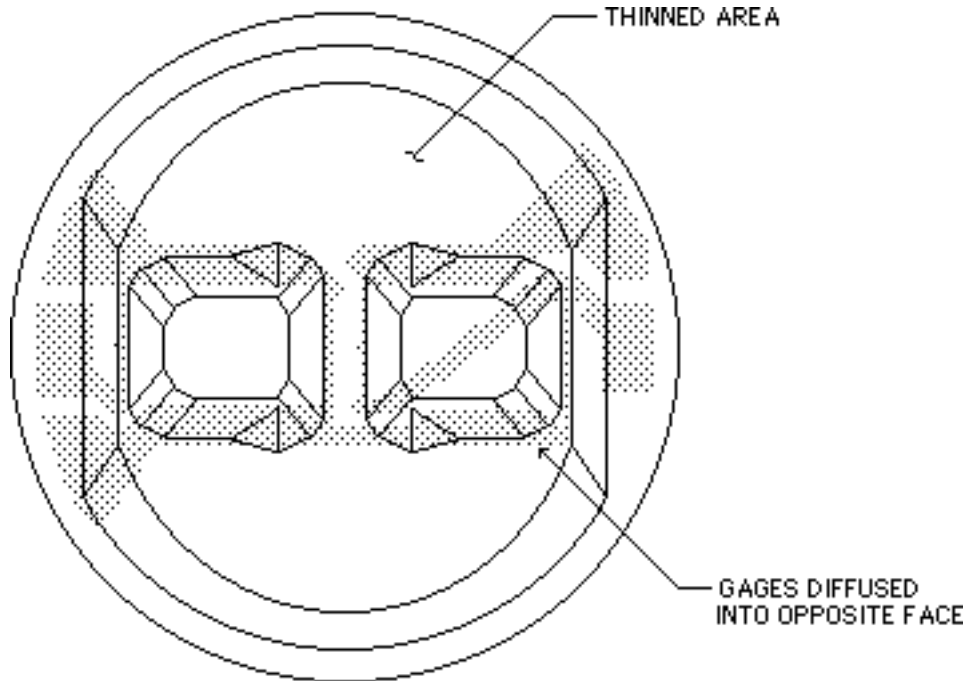

FIGURE 2-1: DIFFUSED, ETCH-CONTOURED PRESSURE SENSOR

3. MICROPHONES

Microphones are very sensitive pressure transducers, which are calibrated in terms of Sound Pressure Level (SPL), rather than common pressure units. SPL is expressed in dB. "Decibel" for pressure levels, voltages, accelerations, and similar measurements is defined by :

$$\text{dB} = 20 \log_{10} \frac{P_1}{P_0}$$

where P_1 is the pressure being characterized and P_0 is the reference pressure. By international agreement, reference pressure for SPL is 0.00002 N/m^2 (pascal) or 2.90×10^{-9} psi. Note also that pressures for SPL are always rms pressure levels.

For more information on microphones, refer to Endevco TP278-- "Microphone Talk."

4. SENSING ELEMENTS

The piezoresistive strain-gage element is a solid-state, silicon resistor, which changes electrical resistance in proportion to applied mechanical stress. Since it is a single crystal it is not only strong but virtually free of mechanical hysteresis with inherently good linearity. The significant characteristic of this element is that its change of resistance is largely relative to its change in length. It has a gage factor many times greater than the typical wire strain gage. Piezoresistive element gage factors range typically from 50 to 200.

ENDEVCO PR PRESSURE TRANSDUCERS INSTRUCTION MANUAL

Diffused Semi-conductor Strain Gages The diffused piezoresistive transducer uses a silicon element for the mechanical structure, and the strain gage is an integral part of the silicon element. The gage is diffused into the structure (Figure 2-2). To accomplish this, IC manufacturing techniques are employed, and the technique lends itself to miniaturization and volume manufacture.

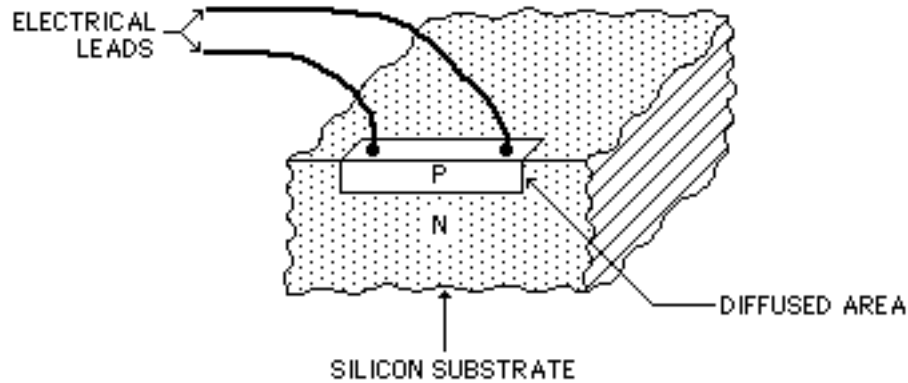

FIGURE 2-2: DIFFUSED STRAIN GAGE

A typical sculptured diaphragm is shown in Figure 2-3. Note the two thicknesses. It is considerably thicker at the outer edge, and it has two islands in the middle section. Notice how closely the islands come to each other and to the edge. This is shown much better in the cross-section in Figure 2-4. It can be easily seen that a distributed load, or pressure, on one side results in stress concentrations at points A, B, and C.

Most devices have been designed to stress the gage material so that the gage increases its length. This is the manner in which larger wire and foil gages are used. Another approach is to use a transverse gage laid lengthwise in the groove. As the groove bends, this gage is strained so that it effectively changes width.

A fundamental benefit from using the transverse gage is that pressure transducer amplitude linearity can be excellent, typically better than 0.1% Best Straight Line (BSL) to full scale. The transverse gage has decreasing sensitivity in tension and increasing sensitivity in compression. Parallel gages have decreasing sensitivity with increasing stress in both tension and compression, so that bridge nonlinearity is the average nonlinearity of both. When used in a bridge configuration, with one element in tension and the other in compression, the transverse gage approach can be better. With transverse gages mounted in tension and compression, their average nonlinearity is close to zero. For a more complete description of sculptured diaphragm pressure transducers, request Endevco TP277.

The major disadvantages of silicon diaphragms are their difficulties of providing water and chemical media protection and their tendency to shatter under particle impingement. Silicon is a brittle material, crystalline in structure, and can crack or shatter on impact. Protective screens are provided or optional on all Endevco models to minimize this property .

5. SENSING BRIDGE

Most piezoresistive transducers utilize four piezoresistive elements connected electrically in a Wheatstone Bridge in a way similar to other resistance strain-gage circuits. See Figure 2-5. A regulated voltage excitation is applied to the bridge input, and the bridge voltage output varies with the pressure applied.

**ENDEVCO PR PRESSURE TRANSDUCERS
INSTRUCTION MANUAL**

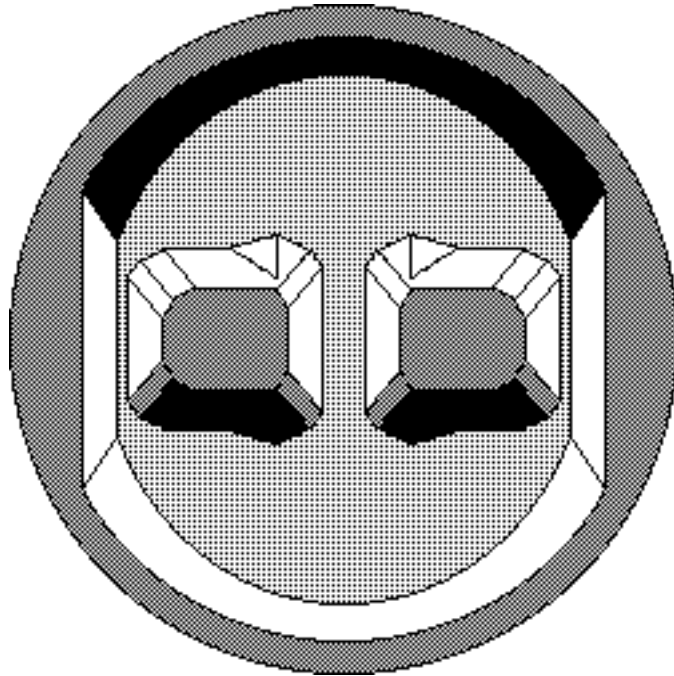

FIGURE 2-3: PRESSURE DIAPHRAGM

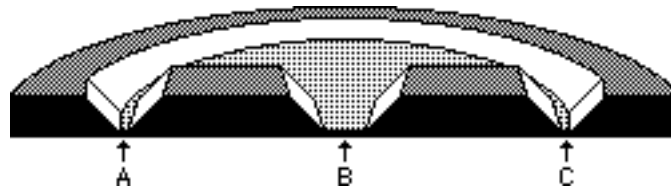

FIGURE 2-4: CUT-AWAY SECTION THROUGH NOTCHES AND ISLANDS

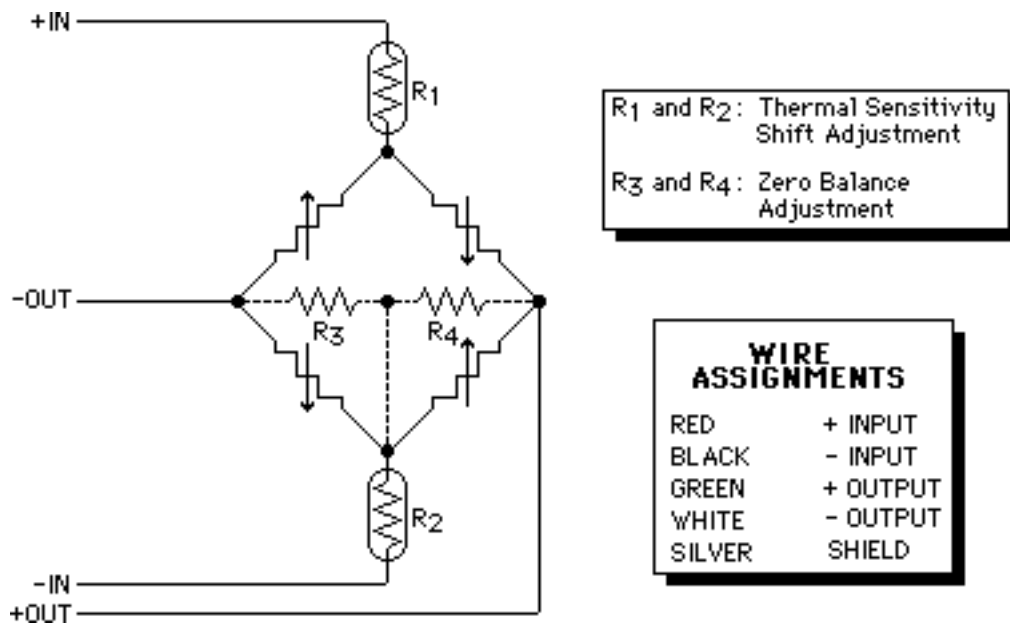

FIGURE 2-5: SCHEMATIC DIAGRAM FOR 4-ARM BRIDGE

ENDEVCO PR PRESSURE TRANSDUCERS INSTRUCTION MANUAL

6. TRANSDUCER DESIGN

Endevco's unique transducer design integrates bridge-balancing and temperature compensating circuitry into the miniature, but rugged, stainless steel case. (Figure 2-6)

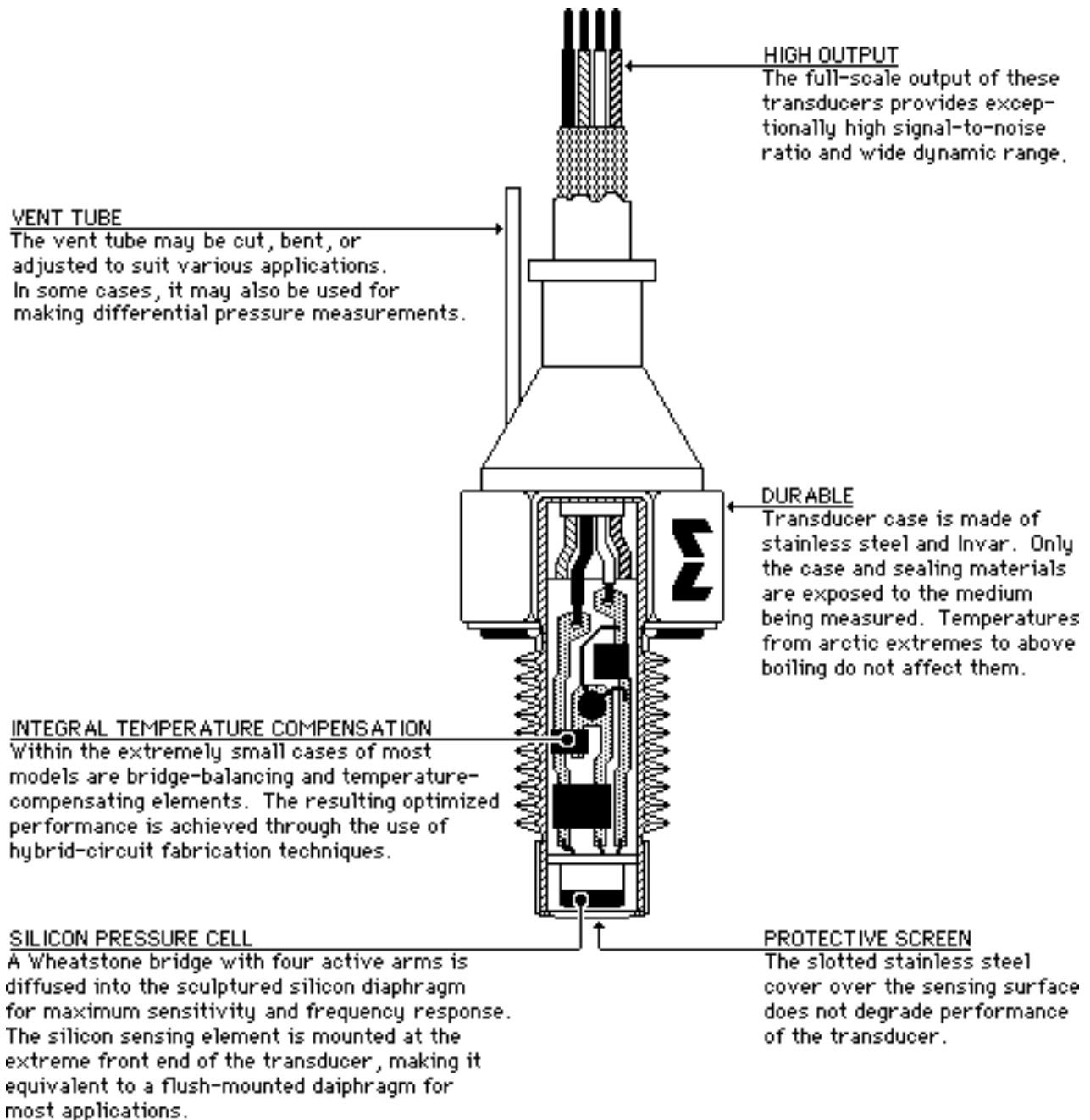

FIGURE 2-6: CUT-AWAY VIEW OF TYPICAL PRESSURE TRANSDUCER

ENDEVCO PR PRESSURE TRANSDUCERS INSTRUCTION MANUAL

SECTION 3: PERFORMANCE CHARACTERISTICS

1. PERFORMANCE CHARACTERISTICS

Specifications of Endevco pressure transducers, on data sheets for each model, follow ANSI and ISA standards. A brief discussion of each specification follows.

2. RANGE

The range of the pressure transducer specifies the recommended maximum peak pressure level for optimum linear response. Most Endevco pressure transducers maintain good linearity up to 3 times the range, and specifications are provided for extended range. This is intended as a safety margin, not for normal use.

Above the range, non-linearity increases, but the transducer continues to operate. As a single degree of freedom system the mechanical response of the diaphragm to an applied pressure is frequency dependent. Do not apply full scale pressure at frequencies above 30% of resonant frequency. This may excite the diaphragm resonance and cause erroneous data. A pressure "snubber," a small orifice, may be used to attenuate high frequencies.

3. SENSITIVITY

The sensitivity of a transducer is defined as the ratio of its electrical output to its mechanical input. Specifically, in the case of piezoresistive pressure transducers, it is expressed as voltage per unit of pressure at the rated excitation. Units of millivolts per psi (mV/psi) are used because Endevco pressure transducers are calibrated and recommended for operation at a specified and fixed excitation voltage of 10.00 Vdc.

A. SENSITIVITY CALIBRATION

Each Endevco transducer is provided with a sensitivity calibration, as measured by a readout device with a high input impedance (loading effects are discussed later). The transducer is operated at rated electrical excitation. The sensitivity is expressed in mV/psi and is numerically equal to:

$$\frac{\text{mV}}{\text{psi}} = \frac{\text{rms mV}}{\text{rms psi}} = \frac{\text{peak mV}}{\text{peak psi}}$$

Calibrated sensitivity is defined as the slope of the linear regression line plotting output vs. input from zero input to full scale input.

4. COMBINED NON-LINEARITY, NON-REPEATABILITY, PRESSURE HYSTERESIS (MAX)

Combined non-linearity, non-repeatability, and pressure hysteresis is the maximum RSS (root-sum-square) average of the three independent parameters discussed below. This is the "error band" calculated as the RSS average of three independent measurements. This is the most meaningful performance characteristic to indicate variations of sensitivity over the range of inputs.

5. NON-LINEARITY, INDEPENDENT

Although a piezoresistive transducer is theoretically linear down to zero pressure, a practical lower limit is imposed by its noise level. As in all electrical conductors, the thermal induced random motions of free electrons cause noise; in addition, the current flow through the diffused gage elements causes some additional noise having the characteristics of Schottky, or shot, noise. As a result, these diffused gage pressure transducers have a wide band noise characteristic of about 5 μV RMS, measured at 68°F (20° C). This corresponds to about 3×10^{-5} psi (0.2 Pa) for a 2 psi (13.8 kPa) full scale transducer. Because this noise level is very small, the lower limit of dynamic range is usually a function of the noise characteristics of the signal conditioning and power supply equipment used with the transducer.

ENDEVCO PR PRESSURE TRANSDUCERS INSTRUCTION MANUAL

Single crystal silicon is a very good spring material, having essentially no plastic zone to its stress-strain curve and very low hysteresis. Because the input pressure to these transducers is supported only by the silicon element, these transducers maintain reasonably good linearity until burst is reached. Although each transducer is identified with a particular full scale range, there is no absolute end to the scale (with the exception of burst). One may elect to use a transducer at some pressure above full scale, or well below full scale, depending on the requirements of the application. Each transducer is tested prior to shipment to a maximum limit for combined non-linearity, non-repeatability, and hysteresis to the "defined" full scale level, and for operation to a specified overrange level, typically 3 times full scale.

The general linearity characteristics of these diffused transducers might best be explained by referring to Figures 3-1 and 3-2, which show the general shape of the input to output curve and the degree of nonlinearity for increasing input for up to three times full scale. Experience shows that the linearity for ranges greater than 5 psi is usually about twice as good as that for the 5 psi range, and the non-linearity of the 2 psi full scale transducer is almost twice as much as that for the 5 psi full scale range.

The linearity shown by Figure 3-2 and which is shown on the specifications for the transducers is the "independent linearity." This is defined as the maximum difference between the calibration point and the linear regression line (least squares fit) drawn through the points for increasing measurand, zero to + full scale. Numerically, this is usually about one-half the value when using an end-point, or terminal based, linearity definition.

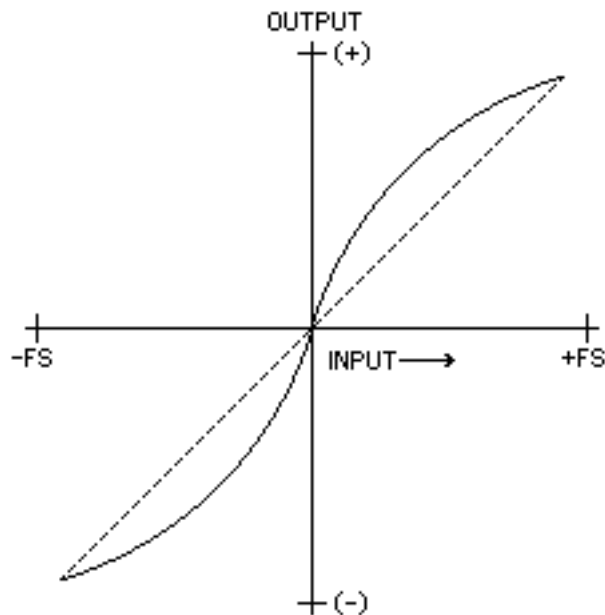

FIGURE 3-1: TYPICAL INPUT TO OUTPUT CURVE

ENDEVCO PR PRESSURE TRANSDUCERS INSTRUCTION MANUAL

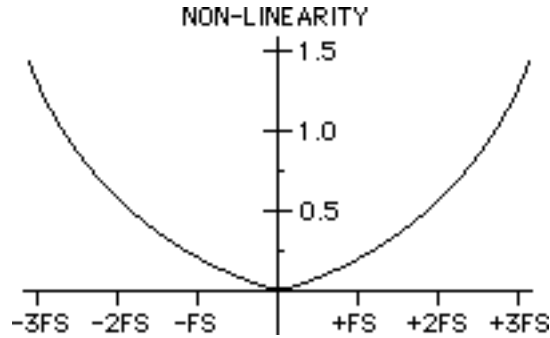

FIGURE 3-2: TYPICAL INDEPENDENT LINEARITY CURVE

6. NON-REPEATABILITY

Non-repeatability (sometimes “repeatability”) is the ability of a transducer to repeat output readings when the same pressure is applied to it consecutively under the same conditions, and in the same direction as shown in Figure 3-3. It is expressed as the maximum difference between output readings as a percent of full scale output (%FSO). Two calibration cycles are used to determine non-repeatability.

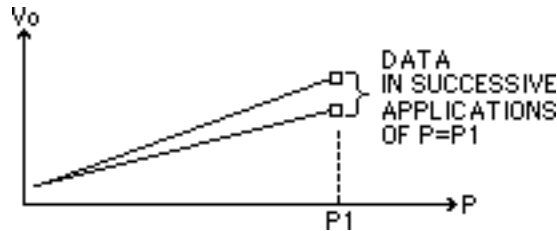

FIGURE 3-3: TRANSDUCER REPEATABILITY

7. PRESSURE HYSTERESIS

Pressure hysteresis is the maximum difference in output, at any pressure, when the pressure level is approached with increasing, then with decreasing pressure. See Figure 3-4.

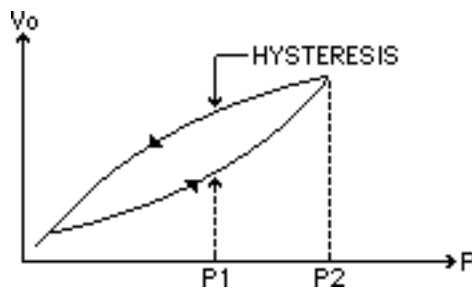

FIGURE 3-4: TRANSDUCER HYSTERESIS

Because of the excellent elastic characteristics of silicon, the hysteresis of these gages is usually quite small, most of the time under 0.1% of full scale, and quite often even 0.03%. As such, the specifications have simply been stated by indicating typical values for non-linearity, non-repeatability, and hysteresis, and then indicating a maximum limit for the three combined.

ENDEVCO PR PRESSURE TRANSDUCERS INSTRUCTION MANUAL

8. ZERO MEASURAND OUTPUT (ZMO)

This characteristic is often called zero balance or zero pressure output. Zero Measurand Output is expressed in millivolts at the output of the transducer under room conditions with full rated excitation but no pressure applied to the transducer.

Although resistance elements in the bridge of a transducer are closely matched and compensated during manufacture, slight differences in resistance exist. The differences result in a small offset (residual dc) voltage at the output of the bridge. This residual voltage is the Zero Measurand Output. Circuitry within associated signal conditioning instruments may provide compensation or adjustment of the electrical zero.

A. MOUNTING EFFECTS

Zero offset can be increased by improper transducer mounting. Any stresses placed on or near the diaphragm will result in changes. Over-torquing of threaded transducers can change ZMO. For threaded devices, a recommended installation torque is indicated on the calibration sheet. Zero offsets are trimmed at Endevco with indicated torque applied.

B. WARM UP

The zero offset will move to its final value while the pressure transducer is being "warmed up". Typical warm-up times to $\pm 1\%$ of final stabilization for Endevco pressure transducers are 1 ms or less, which is provided by our unique diaphragm design.

When making dynamic measurements, the output of the pressure transducer can be AC coupled to the signal conditioner. This completely eliminates the zero offset, greatly reduces thermal zero shift, and provides a controllable high pass filter.

9. ZERO SHIFT (max at 3x Range)

Zero shift (max at 3x Range) is the change in ZMO after application of three times rated full scale (range) pressure. It is expressed in terms of percentage of three times full scale. This, along with the specification for non-linearity at three times range, provides performance information for use between rated pressure range and three times range, in case pressure exceeds design expectations.

10. THERMAL SENSITIVITY SHIFT AND THERMAL ZERO SHIFT

Thermal sensitivity shift and thermal zero shift define the effects on ZMO and sensitivity of operation at ambient temperatures other than 75°F (24°C). Thermal zero shift is specified in terms of the maximum change of ZMO from its room temperature value, as a percent of full scale output.

The operating and environmental temperature ranges for piezoresistive pressure transducers are specified on individual data sheets. The environmental range indicates the limits in which the transducer will not be damaged. The operating range indicates the limits in which the transducer will operate with predictable characteristics, or for which the transducer has been compensated.

Because of variations in material properties, processes, and dimensions, the performance of a population of units of a given design will scatter about the typical. To provide the lowest effect of temperature, the performance is measured for each transducer during the manufacturing process, and resistance values are chosen to compensate for change with temperature. The bridge circuit employed in these transducers is shown by Figure 2-5. The resistance in series is used to reduce the sensitivity variation with temperature. The resistances in parallel with the open arm of the bridge correct for bridge unbalance and balance change (zero shift) with temperature.

A basic feature of the Endevco pressure transducers is that all of the temperature compensation elements are contained within the transducer case. No external compensation module is necessary. Each unit is tested in the manufacturing process and components selected to optimize performance.

ENDEVCO PR PRESSURE TRANSDUCERS INSTRUCTION MANUAL

A. THERMAL SENSITIVITY SHIFT

Sensitivity - The temperature compensation utilized for most standard production units reduces the thermal sensitivity shift to a maximum of $\pm 4\%$ of output at 0°F (-18°C) and 200°F ($+93^{\circ}\text{C}$), referenced to room temperature. This temperature error is sometimes also expressed as a maximum of 0.05% of output/ $^{\circ}\text{F}$ (0.09%/ $^{\circ}\text{C}$). Note that on special order tighter specifications can be met; the compensated temperature range can be suppressed, expanded, shifted up or down; also calibration data can be supplied at any specified temperature within the environmental range. The sensitivity variation with temperature for a typical 8510 with and without the series compensation resistance is shown by Figure 3-5. Uncompensated slope is approximately -0.08% per $^{\circ}\text{F}$ (-0.15% per $^{\circ}\text{C}$) and compensated slope is about -0.016% per $^{\circ}\text{F}$ (-0.03% per $^{\circ}\text{C}$) over most of the temperature range.

Endevco transducer test reports show sensitivity shifts at four temperatures over the compensated temperature range. Approximate distribution of temperature sensitivity errors for standard production model 8510 units is:

% of Units	Maximum Temperature Sensitivity Shift % FSO
100	4.0
75	2.5
50	1.5
25	1.2

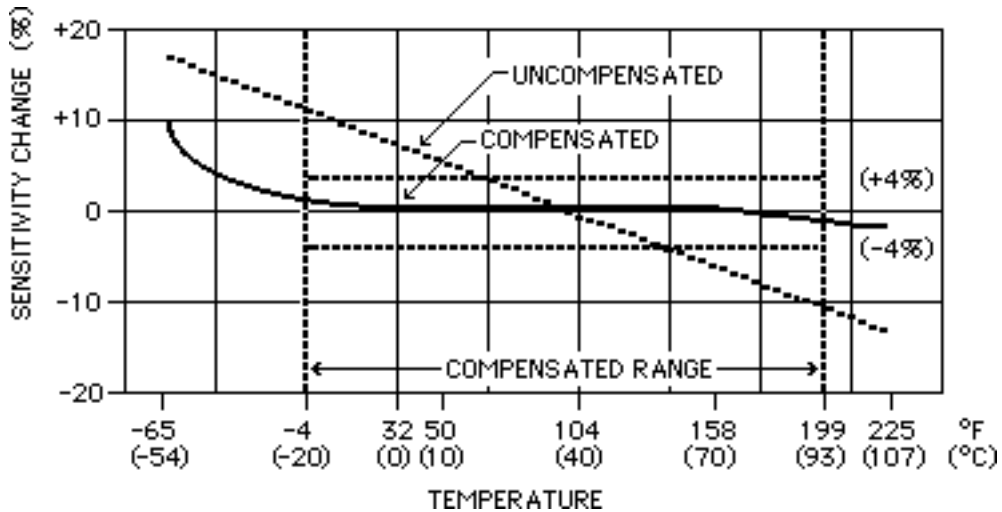

FIGURE 3-5: TYPICAL 8510 SENSITIVITY VS. TEMPERATURE

B. THERMAL ZERO SHIFT

Since the resistance of silicon gages (as well as components in the temperature compensation circuitry) is temperature dependent, input and output impedance is likewise affected by temperature. This effect may be of no particular significance to the user, since the unit is a voltage measuring device.

ENDEVCO PR PRESSURE TRANSDUCERS INSTRUCTION MANUAL

The changes in resistance of the various elements is rarely balanced. As temperature changes, the bridge balance changes, resulting in a ZMO change. Figure 3-6 shows an example of typical thermal zero shift. Endevco transducer test reports show ZMO shift at four temperatures over the compensated temperature range. Approximate distribution of temperature zero errors for standard production Model 8510 is :

% of Units	Maximum Temperature Zero Shift % Output
100	3.0
75	1.5
50	1.0
25	0.5

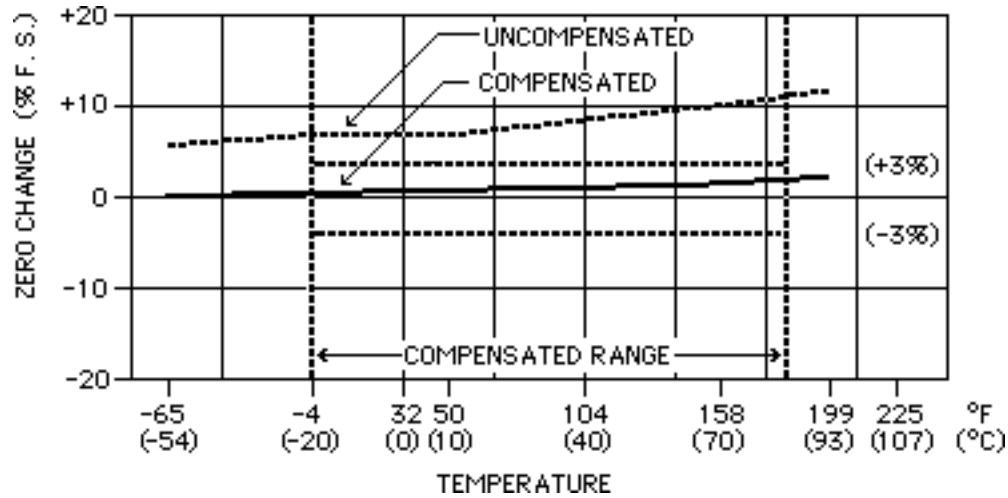

FIGURE 3-6: TYPICAL 8510 ZERO SHIFT VS. TEMPERATURE

3.11 RESONANT FREQUENCY

Resonant frequency is the frequency of pressure application at which the transducer responds with maximum output amplitude. The resonant frequency of a piezoresistive transducer is a function of its mechanical characteristics. A piezoresistive transducer can be represented as a single-degree-of-freedom spring-mass system, the response of which is shown in Figure 3-7 as a function of frequency. Relative response peaks at 30-40 dB at the natural frequency (f_n).

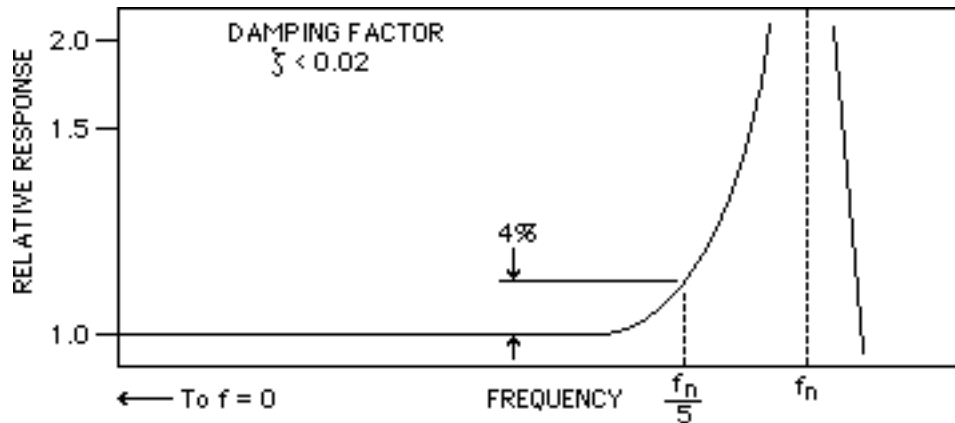

FIGURE 3-7: RELATIVE FREQUENCY RESPONSE

ENDEVCO PR PRESSURE TRANSDUCERS INSTRUCTION MANUAL

This curve can be considered as showing the variation in sensitivity of the transducer with frequency. The response curve Figure 3-7 shows that at 1/5 the resonance frequency, the response of the system is 1.04. This means that the sensitivity of the transducer is 4% higher at that frequency than at the lower frequencies. For this reason, the "flat" frequency range should be considered limited to 1/5 the resonant frequency.

The silicon diaphragm, because of its small mass, has an extremely high resonant frequency. Endevco has done significant testing on the diaphragm resonant frequencies for each class of transducer. For instance, the 8510B-15 has a resonant frequency of 130 KHz. This number includes the protective screen on the transducer and the resultant dead volume of 0.0003 in³ (0.005 cc). A rule of thumb for dynamic measurement is to select a device with a resonance at least five times the highest frequency present. With Endevco transducers this is usually not a problem, because they have unusually high resonant frequencies for their ranges.

12. RISE AND RESPONSE TIME

Pressure transducers provide the user with the capability of monitoring extremely rapid rise time pressure pulses. The rise time of the transducer is much faster than the period to which it will respond accurately. A rise time (t) to which the transducer will respond linearly to within $\pm 5\%$, can be expressed as a function of the period to which the transducer has a flat response (T)

$$T = \frac{1}{0.2f_n} \quad \text{where } f_n = \text{resonant frequency}$$

$$t = \frac{T}{4} = \frac{1}{0.8f_n}$$

Example:

The 8510B-500 transducer, which has a resonant frequency of 500 kHz has a flat response period T:

$$T = \frac{1}{0.2 \times 500,000\text{Hz}} = 10 \times 10^{-6}\text{sec} = 10 \text{ msec}$$

$$\pm 5\% \text{ Rise Time } t = \frac{T}{4} = \frac{10 \text{ msec}}{4} = \frac{1}{0.8 \times 500 \times 10^3} = 2.5 \text{ msec}$$

13. THERMAL TRANSIENT RESPONSE

Thermal transient response is the output of the transducer when subjected to a step-function temperature change from room temperature to the upper limit of the operating range.

The compensated temperature range is the range in which the transducer will meet the specifications for Zero and Sensitivity Shift as given in the data sheets. Above and below this range, the transducer will continue to operate but the specification will gradually increase from the data sheet values. COMPENSATION IS ONLY VALID FOR EQUILIBRIUM TEMPERATURE, NOT FOR THERMAL TRANSIENTS. All Endevco pressure transducers are sample tested according to Paragraph 6.7 of ISA Specification S37.10. Results are shown on the Specification Sheets.

The standard test method of transferring the unit from a 68°F (20°C) to 194°F (90°C) water results in a transient error as shown in Figure 3-8. Note that the effect on zero balance is extremely small and of short duration. A somewhat larger error results from its change in sensitivity, -5% FSO being a typical error in output when the unit (with uncovered diaphragm) is simultaneously subjected to a full range pressure input and a step temperature change of 126°F (70°C). For a more complete discussion of temperature transient effects refer to Endevco TP279.

ENDEVCO PR PRESSURE TRANSDUCERS INSTRUCTION MANUAL

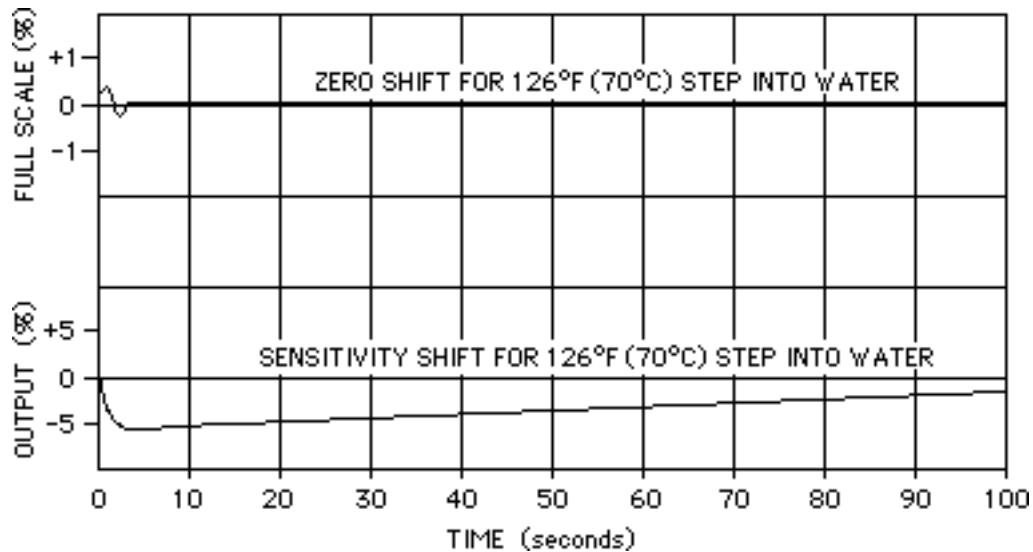

FIGURE 3-8: TYPICAL 8510 TEMPERATURE TRANSIENT EFFECT

A. WHY TRANSDUCERS RESPOND TO TRANSIENT THERMAL INPUTS

Transient thermal environments can affect transducers in several ways. As a means to simplify laboratory simulations for the various thermal inputs, and to categorize these, they can be divided into two primary modes. The first is heat transfer by conduction and convection, and the second, heat transfer by radiation. With conduction or convection, heat is simply transferred in or out of a transducer at a fast rate, causing temperature gradients. For "flush" diaphragm type pressure transducers, this must be further refined to include the situations where heat is conducted into or out of the diaphragm through temperature changes in the pressure medium. These affect strain-gage type transducers in the following three ways.

- (1) Errors occur simply because the strain gage elements can be at a different temperature than their supporting structure or other temperature compensation elements.
- (2) Because the strain gage elements consume electrical energy, which is removed by heat transfer, changes in the heat transfer characteristics of the pressure media can affect the equilibrium temperature.
- (3) As heat is transferred into the diaphragm, if it is not uniform to each of the resistors in the bridge, an unbalance in the bridge will occur.

These three factors not only cause a zero shift in the resistive bridge, but they can also change the sensitivity factor for the transducer. Both characteristics should be evaluated.

B. EFFECT ON PERFORMANCE

With the sculptured diaphragm the effects from transient temperature are much less than with a flat diaphragm, because the diaphragm is considerably thicker over most of its area. In short, diaphragm bending is considerably less from any surface heating than when using the flat diaphragm. Because the diaphragm is thicker, there is also much greater thermal mass to dissipate the self-generated heat from the strain gages. This means that changes in the pressure media will cause less strain-gage temperature change. Laboratory evaluations have been conducted by suddenly immersing the transducer into hot water. Test results for several transducer designs are shown in Figure 3-9.

ENDEVCO PR PRESSURE TRANSDUCERS INSTRUCTION MANUAL

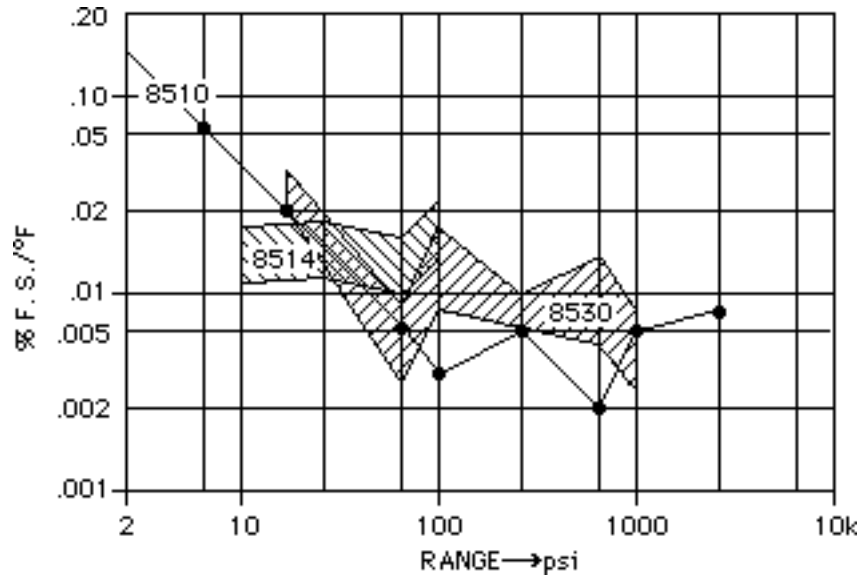

FIGURE 3-9: TYPICAL PR ZERO OUTPUT CHANGE FROM TEMPERATURE TRANSIENT

14. PHOTO FLASH RESPONSE

Photo flash response (per ISA S37.10, Para. 6.7, Proc II) is the output of the transducer when subjected to the flash from a clear Number 25 flash bulb approximately two feet in front of the transducer.

The photosensitivity of silicon quite often will render silicon diaphragm pressure transducers susceptible to radiation. The resulting transient output can be significant for applications where high intensity light can impinge on the diaphragm (such as in explosions or in engine combustion chambers). Endevco has employed several solutions to this - not the same for all designs. In some cases it is advisable to cover the diaphragm with an opaque material. The diaphragm coating does slightly affect acceleration sensitivity and frequency response, and is not usually recommended for ranges below 100 psi. For low range units (2 to 100 psi) opaque silicone grease over the diaphragm has been found to be quite effective.

The unique construction of Endevco Models 8520 and 8531 makes them very insensitive to flash response. Also models 8530B and 8511A have an opaque metallic coating on the diaphragm (See Section 3.14.B).

In short, flash sensitivities of silicon diaphragms vary widely from unit to unit, and it is rather common to obtain a full scale output from a high intensity flash of light.

A. METHODS TO REDUCE FLASH RESPONSE

Several methods have been available in the past to reduce thermal transient inputs into miniature pressure transducers. For example:

- (1) Protect or shield the diaphragm from the transient with a baffle or shadowing screen.
- (2) Place an opaque grease in front of the diaphragm.
- (3) Add an opaque material which adheres to the diaphragm, such as black tape or RTV.

ENDEVCO PR PRESSURE TRANSDUCERS INSTRUCTION MANUAL

The construction approach for Endevco's design has also helped to reduce its response to transient thermal inputs. The diaphragm is positioned behind a screen, essentially within a small cavity. Figure 3-10 shows three typical construction approaches.

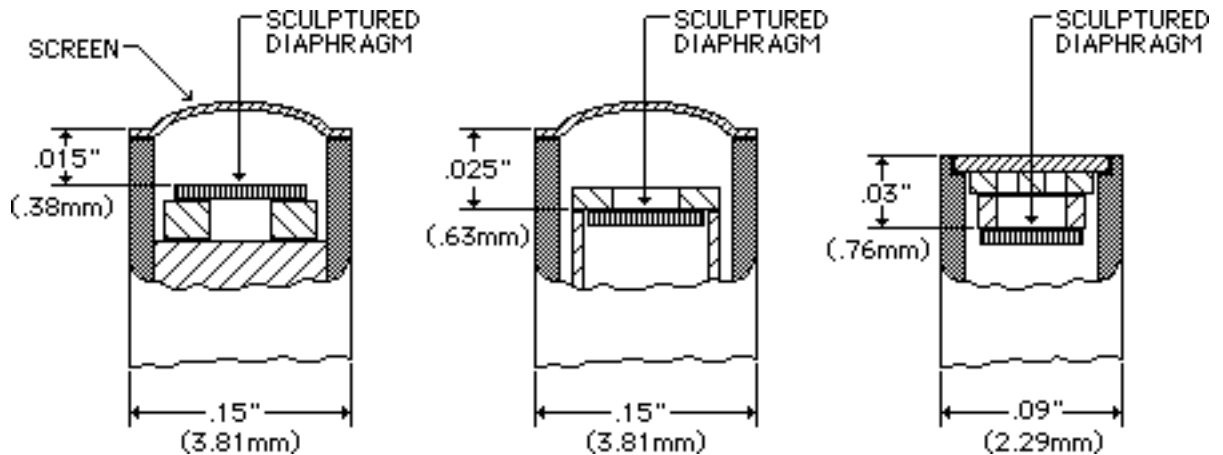

FIGURE 3-10: TYPICAL PR TRANSDUCER CONFIGURATIONS

These provide some protection and screening from transient thermal energy. Because a cavity is placed in front of the diaphragm, the response time to pressure inputs is made more complex. Tests in pressure shock tubes, however, show that the rise time is fast and the resonant frequencies of these cavities are usually over 100,000 Hz with all of the screen holes open. When more than about one-half of the holes are blocked the rise time increases. These effects are discussed in greater detail in Endevco Tech Paper 279.

Improvements for transient thermal conditions can be achieved by placing grease or rubber in front of the diaphragms. Tests have shown that rubber can generally be used for designs with ranges of 100 psi or greater; below that, adding a gummy or high hysteresis material will affect accuracy of the transducer. For the lower ranges, black grease has been successfully used. For either of these approaches the acceleration sensitivity increases, and the resonant frequencies decrease because of the added mass on the diaphragm.

Most ranges of most models can be successfully treated to completely eliminate flash response with minimum performance degradation by using a reflective silicone gel.

B. METALIZATION

For some models a much better method was developed using a nickel alloy with a coefficient of expansion close to silicon. The material has high reflectivity, and it adheres well to silicon. It is applied by a sputtering process, since vapor deposition of alloys changes their composition. (Generally, sputtering also provides better adhesion than vapor deposition.) The thickness of the metallic coating can be varied, depending on the thickness of the diaphragm and the application. The increase in the thickness of the diaphragms from adding these coatings is less than 3%. The accuracy of the transducers is not degraded by the metallic coating, although the sensitivity is slightly reduced for the lowest range, 2 psi, because of the increased stiffness. The addition of this special coating typically reduces the flash sensitivity of these transducers by at least 100 times. For total elimination of flash response, a grease or rubber coating is still required.

ENDEVCO PR PRESSURE TRANSDUCERS INSTRUCTION MANUAL

15. ACCELERATION SENSITIVITY

Endevco's pressure transducers, by design, are highly insensitive to acceleration inputs. Acceleration sensitivity is the sensitivity of the pressure transducer diaphragm to applied acceleration. The reaction of the device diaphragm to acceleration is a function of its stiffness, mass, thickness, and diameter. Acceleration sensitivity is a function of both transducer overall diameter and pressure range. Sensitivities as low as 0.00005% FS/g are available in the pressure sensitive directions. Therefore, for a 1,000g acceleration input the total error might be as low as 0.05% Full Scale. Cross acceleration sensitivities are generally less than 1/5 of that in the sensitive directions. Values listed on each individual data sheet are typical values from sample tests.

The stiff low-mass diaphragm exhibits a resonant frequency over 70 KHz for all ranges, and much higher for most. Therefore, its resonant excitation by environmental vibration or shock is highly unlikely.

Thus the acceleration sensitivity stated on the data sheet can be used with peak shock or peak vibration amplitudes to calculate vibration or shock sensitivities.

16. BURST PRESSURE

Burst pressure (max, diaphragm) is the pressure which may be applied to the diaphragm, and the portion of the space subjected to the pressurized fluid medium, without rupture of the diaphragm.

This is a *static* pressure rating; peak pressure greater than the specified range should not be applied at frequencies greater than 30% of resonance frequency. The resultant mechanical amplification effect near the resonant frequency may cause erroneous data, or in extreme cases may burst the diaphragm.

17. FULL SCALE OUTPUT

Full scale output is defined as transducer output from zero to + full scale (rated range). Endevco pressure transducers have a typical FSO of 200 to 500 mV, depending on model.

18. SUPPLY VOLTAGE or EXCITATION

Supply voltage or excitation is the external voltage applied to the transducer for its operation within specified tolerances. Endevco calibrates pressure transducers with an excitation voltage of 10Vdc, ± 5 mVdc.

The excitation across the piezoresistive elements causes a finite current to flow through each element. The I^2R heating results in an increase in temperature of the gages slightly above ambient, which increases the resistance of the elements. Differentials in this effect may cause the output voltage to vary slightly with time until the temperature is stabilized. With 10 Vdc excitation, stabilization to within 1% usually occurs within a few milliseconds when tested at standard barometric conditions. To be on the safe side, a 15 second warmup time is recommended. With less excitation voltage, the warmup is faster; however, it should be recognized that the response is not instantaneous.

Measurements have also been made at excitations other than 10 Vdc to investigate effects. As a result of these tests, maximum excitation without damage is usually specified at 18 Vdc, and excitation to 15 Vdc may improve signal-to-noise ratios in some applications. With some transducers, excitation at other than 10 V can change zero output, sensitivity and their shift with temperature. Figures 3-11 and 3-12 show this effect tested on a sample 5 psig full scale transducer. Because of this, calibrations should be completed using the power supply excitation planned for use in the application.

ENDEVCO PR PRESSURE TRANSDUCERS INSTRUCTION MANUAL

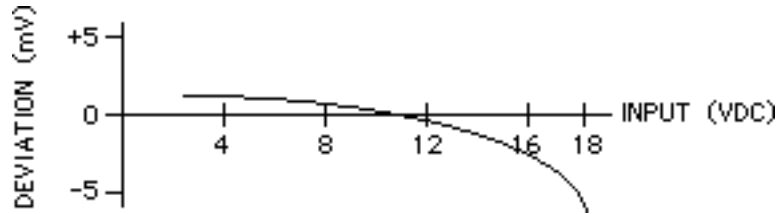

FIGURE 3-11: ZERO CHANGE WITH INPUT VOLTAGE CHANGE

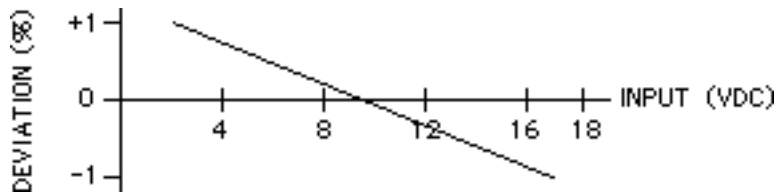

FIGURE 3-12: SENSITIVITY CHANGE WITH INPUT VOLTAGE CHANGE

Traditionally, the excitation has been provided by a battery or a constant-voltage supply. Other sources of excitation, such as constant-current supplies or ac excitation generators, may be used. The sensitivity and temperature response of a piezoresistive transducer will depend on the kind of excitation applied. Therefore, it must be operated in a system which provides the same source of excitation as used during temperature compensation and calibration of the transducer. Constant current excitation of standard Endevco transducers will cause large thermal errors.

19. POLARITY

For many measurements, it is necessary to know the polarity of the system output signal relative to the direction of pressure on the transducer. To determine this, the polarity of the transducer output and the input-output phase relationship of the amplifier must be known.

Unless otherwise specified, all Endevco pressure transducers produce a positive output signal when the pressure increases. Polarity of the excitation voltage must be applied in accordance with the specifications on individual transducer data sheets. Endevco maintains standard strain gage practice with color codes of red for positive excitation, black for negative excitation, green for positive output signal, and white for negative output signal.

20. INPUT/OUTPUT RESISTANCE

Input resistance and output resistance are measured between input leads and between output leads with a precision ohmmeter using 10 volts or less applied voltage. This measurement is extremely temperature-sensitive, and may vary significantly with small temperature variations. The main uses of these measurements are to calculate excitation current, and to be sure the bridge is not open or shorted.

21. ISOLATION RESISTANCE

Isolation resistance is the lowest value of resistance measured between all leads tied together and the shield, all leads tied together and the transducer case, or cable shield and transducer case. This measurement is made using a megohmmeter with 50 volts applied.

ENDEVCO PR PRESSURE TRANSDUCERS INSTRUCTION MANUAL

SECTION 4: ENVIRONMENTAL

1. TEMPERATURE

High Temperature Limit: For the standard Model 8510, high temperature is limited to 250°F (121°C). For operation above 250°F, the unit must be installed into a water-cooled jacket, or Endevco can supply an ablative coating over the diaphragm which withstands 2000°F (1093°C) for short time durations.

Low Temperature Limit: The standard Model 8510 has been specified at the typical low end of the military specifications, -65°F (-54°C), however, some successful tests have been performed at -300°F (-184°C). For operation below 0°F (-18°C) Endevco can supply temperature compensation for the temperatures of interest.

For sustained operation, without auxiliary cooling, at temperatures from 220°F (105°C) to 575°F (300°C), Endevco developed the 8520 and 8540 series. Endevco TP281 describes the specially constructed silicon/silicon dioxide diaphragm and the overall transducer construction.

2. ACCELERATION, SHOCK AND VIBRATION

Environments of steady state acceleration, shock, and vibration may cause spurious output from a transducer. In severe environments, or when vibratory energy is significant at frequencies near the diaphragm resonance, the transducer may be damaged. However, Endevco transducers are very rugged and have been successfully used in very severe environments.

Most Endevco pressure transducers are qualified for at least 1,000 g acceleration, 1,000 g pk vibration, and 10,000 g pk shock environments. If the shock or vibration environment contains significant energy at frequencies above 1/3 the resonant frequency of the transducer, it is possible to excite the diaphragm resonance. Unless the medium provides significant damping, the diaphragm may be broken. These transducers are generally quite rugged when mounted for use, and can also easily withstand normal handling. Always handle transducers carefully and gently, like delicate instruments. The miniature cables are especially susceptible to damage.

3. RF AND MAGNETIC FIELDS

Normally encountered magnetic and RF fields have negligible effect on the piezoresistive strain-gage elements. Adequate isolation must be provided against ground loops and stray-signals. High intensity RF fields may require special shielding of the transducer, cable, and amplifier.

Endevco's four-conductor shielded cables provide above-adequate shielding for most laboratory, field, and industrial environments. To prevent possible ground loops, the transducer case is insulated from the cable shield. The shield should be grounded at the signal conditioner. The case will be grounded to its mounting structure and the medium being measured. In applications with non-conductive mounting structure and low-conductivity media, special case grounding provisions may be required to provide maximum shielding.

Endevco's transducers are highly resistant to any effects of magnetic fields, even of very high intensity. They can, therefore, often be used in environments where other sensing mechanisms are not acceptable.

4. SEALING AND HERMETICITY

Most Endevco pressure transducers are epoxy sealed (between diaphragm and case) against leakage through the measuring system. Maximum leak rate is about 10^{-5} std cc per second.

The 8530 series of absolute pressure transducers uses an evacuated hermetically-sealed sensing module, but the module is then epoxy-sealed to the case.

ENDEVCO PR PRESSURE TRANSDUCERS INSTRUCTION MANUAL

Model 8531 utilizes Endevco's DURASENS® pressure transducer diaphragm construction, which provides a hermetically sealed pressure port. For additional protection against leakage in the event of diaphragm rupture, secondary containment is provided for pressure up to 500 psi. This transducer's hermetic seal has a leak rate less than 10^{-8} std cc per second.

5. MEDIA

Most specifications for pressure transducers refer to the "front" (pressure sensitive) end of the transducer. When discussing pressure media, pressure ratings, and temperature, the electrical lead end ("back") must be specified separately.

A. PRESSURE SENSITIVE END

Typical silicon diaphragm pressure transducers are compatible with clean dry gases, non-corrosive, medium pH liquids, and common oils. They are not compatible with corrosives, high or low pH liquids, solvents which might attack epoxy, or long exposure to water. Contact Endevco for detailed media compatibility.

Diaphragms are coated with Parylene C for protection against humidity. This also provides up to a few hours protection against exposure to water. An adequate time between exposures to water must be provided to allow water absorbed by the coating to dry out.

Many models can be protected from specific media, such as water, by special coatings applied to the diaphragm. For more information contact Endevco.

Model 8531, with DURASENS diaphragm construction, is compatible with most common media including water. Materials exposed to the medium are 6AL4V titanium, Pyrex®, silicon, and the Viton® O-Ring. Other O ring materials are available.

B. ELECTRICAL LEAD END

The reference tube or reference pressure side of standard Endevco transducers opens directly into the inside of the case. This area can only be exposed to non-conducting, non-corrosive media. DO NOT expose the reference side of the transducer to WATER or MEDIA CONTAINING WATER. This may cause shorting of the electrical circuitry and will permanently damage the transducers. In applications requiring reference to conductive media, it is possible to back fill the transducer with silicone oil, or other similar instrument oils, to act as a fluid barrier to the external media. This is best achieved by vacuum impregnation to remove air bubbles from the reference cavity.

Internal components are coated with Parylene C for high humidity protection. Standard Teflon insulated wire used for lead exit DOES NOT SEAL against water intrusion and the electrical end of standard transducers cannot be submerged in water without damage.

6. NUCLEAR RADIATION

Although no quantitative data is available for pressure transducers, Endevco's experience with piezoresistive accelerometers indicates that most models will probably not perform satisfactorily in high radiation environments. Materials and designs of most models have not been optimized for maximum resistance to radiation.

However, 8520 and 8531 series designs are such that they can be expected to provide significantly better radiation resistance than other models.

ENDEVCO PR PRESSURE TRANSDUCERS INSTRUCTION MANUAL

SECTION 5: APPLICATION INFORMATION

1. CONNECTION DIAGRAMS

Endevco piezoresistive pressure transducers incorporate integral compensation elements within the transducer case. Since there is no external compensation module, the leads (cable) may be cut off as short as necessary. Electrical connections require only that correct polarity of excitation (input) and signal (output) be observed. (Refer to Figure 2-5)

2. MOUNTING TECHNIQUES

In order to achieve accurate measurements with your Pressure Transducers, it is important the Pressure Transducer diaphragm be allowed approximately 0.010 in (0.254 mm) radial and axial clearance within your pressure measurement volume.

CAUTION: Any mechanical loading other than distributed fluid pressure loads will cause stress concentration in the diaphragm and will result in erroneous data and/or possible failure of the device. **DO NOT PRESS ON THE DIAPHRAGM AT ANY TIME.** Be sure that mounting of the device does not transfer stress to the diaphragm. The case and internal designs of Endevco pressure transducers provide the maximum possible mechanical isolation considering size limitations. However, care must still be exercised when mounting. Bending moments or mechanically stressing the device will usually result in asymmetric bending of the stress sensitive diaphragm and will evidence itself as a large zero shift or highly non-linear outputs. When mounting the pressure transducer, it is advised that the output of the unit be continually monitored for shifts or deviations of any type. Mounting torque for threaded transducers is provided on product data sheets. Consult with Endevco for recommended mounting techniques and refer to individual transducer data sheets. If using epoxy or other hard potting compounds for mounting of the transducer, **KEEP THE EPOXY AWAY FROM DIRECT CONTACT WITH THE DIAPHRAGM PERIMETER.** Any contact with the diaphragm may transmit stresses from the test object directly into the diaphragm causing zero shifts, erroneous data and thermal drifts. If it is necessary to fill a void near the diaphragm, use a soft potting material such as RTV silicone rubber which will not transmit stress. Flat units are particularly susceptible to bending stresses as a result of their low profile. Be sure to mount these on a flat surface without bending forces.

A. STRAIN SENSITIVITY

(1) Threaded Mounting — All Endevco threaded mount transducers are calibrated and tested while mounted at the specified torque. For optimum performance, mounting holes should be Class 2, with perpendicularity of the hole to the mounting (sealing) surface of +/-6 minutes. The sealing surface for the O-ring should have a surface finish better than 32 microinches RMS. (Detailed mounting dimensions and tolerances are provided on each data sheet.)

Mounting dimensions with tolerances outside these specifications may cause increased ZMO, increased thermal zero shift, or seal leakage.

Avoid any stresses in front (toward the diaphragm) of the mounting threads.

When threaded configuration transducers are mounted as specified, they are highly immune to effects of strain in the mounting structure.

(2) Cylinder Configuration — Because of their smaller size, unthreaded cylindrical configurations are more sensitive to case strain than threaded designs. They should always be mounted with a relatively flexible adhesive such as Dow Corning Silastic 738. Mounting detail dimensions are provided on each data sheet.

It is especially important to avoid application of adhesive near the front of the case (as shown on the data sheet mounting drawings). No stresses should be imposed on the front portion of the case.

ENDEVCO PR PRESSURE TRANSDUCERS INSTRUCTION MANUAL

When cylindrical configuration transducers are mounted as specified, they are highly immune to effects of strain in the mounting structure.

(3) Flat Transducer (e.g. 8515-15) — The miniature 8515 series transducer, shown in Figure 5-1, has been shown to have excellent strain isolation. As an example the strain error for a 15 psi unit of 0.004 equivalent psia is only 0.027 percent of full scale pressure output. However, it should be recognized that this direct strain input to the gages is a constant percentage of full scale. Therefore, this same strain error for a 50 psia unit is approximately 0.013 equivalent psia or 0.027 percent of full scale.

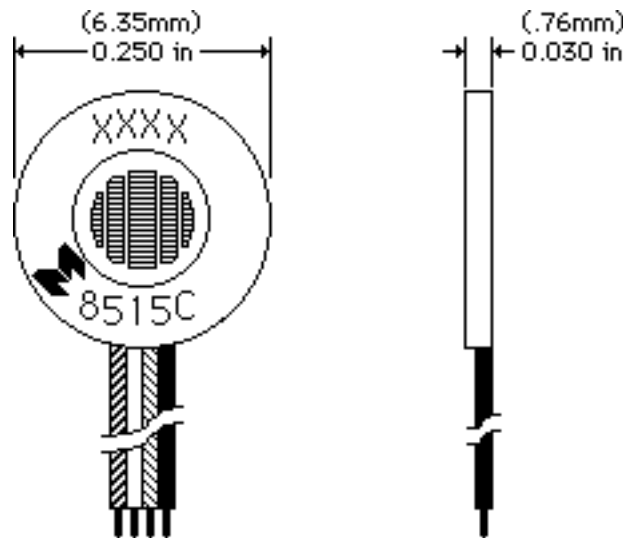

FIGURE 5-1: LOW PROFILE PR TRANSDUCER

This is a cement-mounted transducer and many methods of mounting as well as types of bonding materials may be used.

Figure 5-2 shows three mounting methods: a) the unit is recessed and an epoxy is used to fill the cable channel and is then carefully machined flush with the surface, b) RTV bonded to a surface with tape overlay on the cable and, c) an overlay of tape on the units and cable with a circular cutout in the tape to allow the transmission of the pressure to the sensing diaphragm.

If removal of the transducer without damage is desired, the selection of adhesive is very important. The housing of the transducer is very thin and can easily be damaged from bending and prying under the edge. Also, solvents for the adhesive may damage the transducer interior if allowed into the pressure inlet area. Silicone RTV adhesives or wax can be used for mounting and can be cut away or removed with the application of heat to free the transducer without damage.

Another factor associated with mounting materials is their effect on the transducer when installed on structures which are subject to bending. Structure surface strains which are transmitted to the base of the transducer result in an error signal output. The design of this transducer provides for base strain isolation within the assembly. However, its performance can be enhanced if additional strain isolation is provided by using soft mounting materials or by reducing the mounting area. Figure 5-3 shows the results of base bending tests of a 15 psia transducer mounted on a 0.47 in. (12 mm) thick steel beam. When mounted with silicone rubber of about 70 shore hardness and 0.008 in. (0.2 mm) thick, the error is very small and at 250 microstrain is equivalent to only 0.001 psi output, see Curve c. The error increases as shown in Curve b when the transducer was mounted with a thin bondline of RTV. Even when rigid mounted with a thin glueline of a rigid cyanoacrylate adhesive the error is only 0.008 psi (55Pa) at 250 μ strain as shown in Curve a. As shown in Figure 5-3, errors increase linearly as base strain increases. Incrementally rotating a test unit through 360° has verified that the strain sensitivity error is relatively independent of orientation to bending.

**ENDEVCO PR PRESSURE TRANSDUCERS
INSTRUCTION MANUAL**

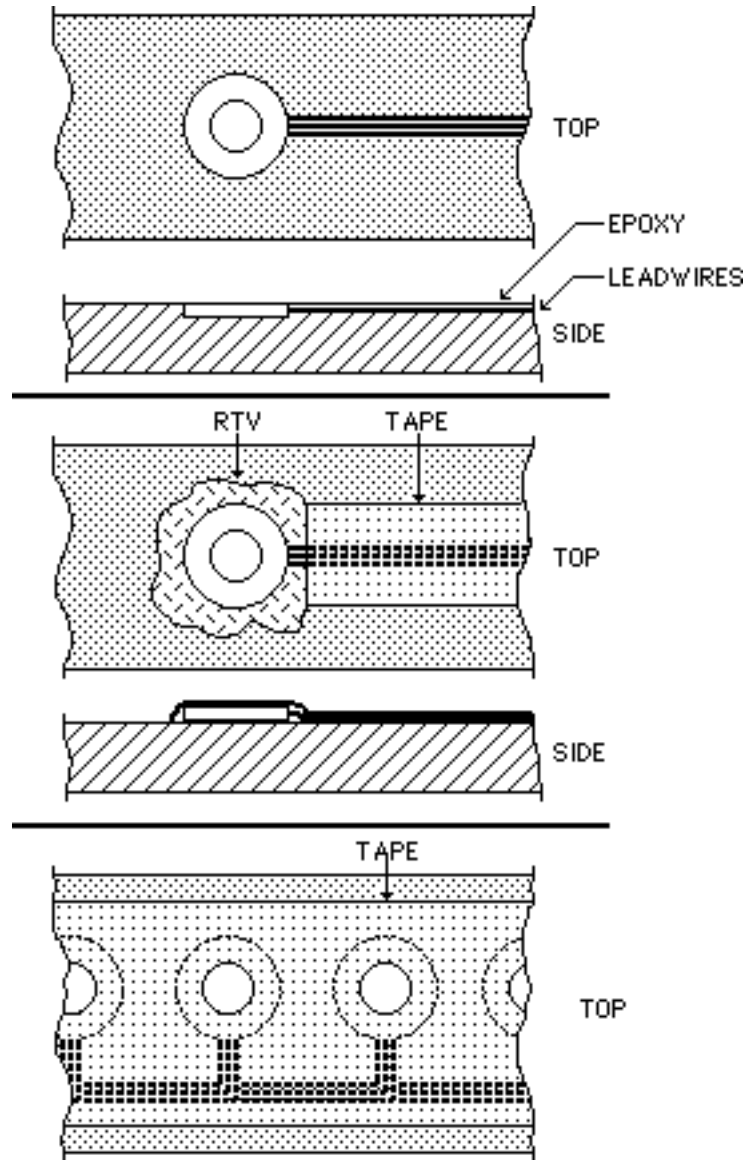

FIGURE 5-2: MOUNTING METHODS FOR LOW PROFILE PR TRANSDUCER

In addition to the effects of mounting materials on base strain sensitivity, the thickness of the structure on which the transducer is mounted also affects the output. Thinner beams such as blades or airplane skin typically bend with smaller radii of curvature than the 0.47 in. (12 mm) thick beam used for the test in Figure 5-3. This results in increased error from strain sensitivity of the transducer approximately inversely proportional to the beam thickness. Bending beam tests have shown that on a 0.12 in. (3 mm) thick beam, the error at 250 μ strain would be approximately 0.004 equivalent psi output with the transducer mounted as in Curve c of Figure 5-3, compared to .001 psi on the 0.47 in. (12 mm) thick beam.

ENDEVCO PR PRESSURE TRANSDUCERS INSTRUCTION MANUAL

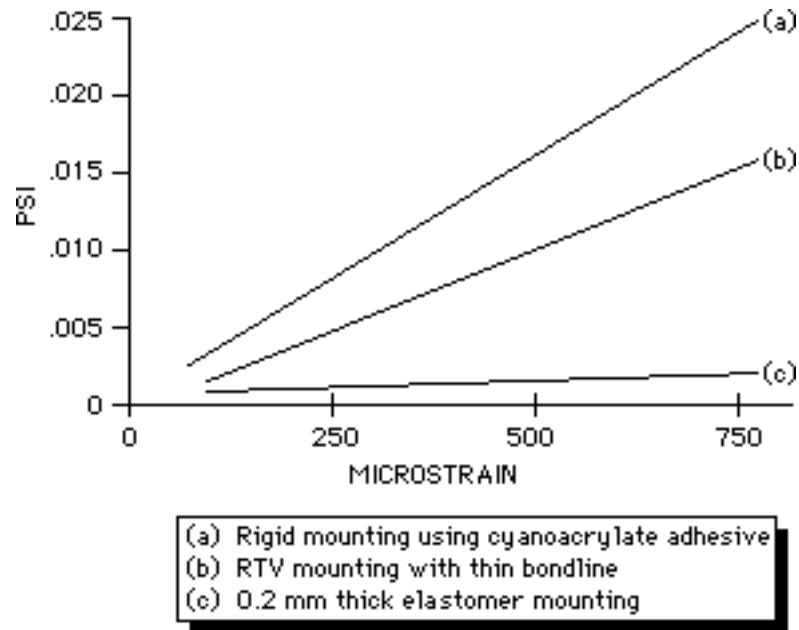

FIGURE 5-3: TYPICAL BASE STRAIN SENSITIVITY

3. INSULATION

The case of the transducer acts as a mechanical and electrical shield for the sensing elements. It is normally electrically insulated from the elements and is not connected to the shield of the cable. The case is assumed to be grounded to the structure in which it is mounted.

Insulation resistance between all leads connected together and the transducer case or the shield is 100 megohms (minimum) at 50 volts.

The gage elements are insulated from the pressure medium by the silicon diaphragm. In all Endevco designs, the gage elements are diffused into the back (inside) side of the diaphragm.

4. CABLING

The cable which connects a transducer to its matching electronics is an important part of the over-all measurement system. It must transmit the transducer signal to the associated signal conditioning equipment without distortion or introduction of noise. Cables must also not affect transducer or test specimen characteristics. Good transducer cables are as small, light and flexible as possible, considering their specific intended application.

A. STANDARD CABLES

Each Endevco transducer is equipped with an integral shielded multiconductor cable or individual lead wires, typically 30 in. (0.76 m) long. The lead wires are color coded for ISA standards. (Refer to Figure 2-5)

Individual lead wires are Teflon insulated. Outer cable jacket materials vary - see individual data sheets.

Because they are designed for maximum flexibility and micro-miniature size, these cables should be handled with care; they can be damaged if misused. They should not be stepped on, kinked, knotted, etc. The soft silicone outer jacket of many cables is easily cut, so care should be exercised in cable routing.

ENDEVCO PR PRESSURE TRANSDUCERS INSTRUCTION MANUAL

When possible, the cable should be tied down within two to three inches of the transducer. Long, unsupported length of cable may load the test specimen and lead to cable damage. Good housekeeping should be observed; excess cable should be neatly coiled and tied down. In humid applications, it is good practice to provide a drip loop at the transducer. It may also be advisable to seal the cable to prevent moisture from entering the cable assembly.

B. SPLICING AND EXTENSION CABLES

Leads may be spliced using good instrumentation practice. Care must be taken to minimize the resistance of the splice. The effects of cable resistance on sensitivity and the effects of RC filtering in the shielded cable (see 5.6.C) must be accounted for when accurate effective sensitivity is needed.

Welded or crimped splice and copper extension wire are preferable to reduce the likelihood of thermoelectric generation of error voltages.

For best protection from EMI/RFI induced noise, any extension cable should be shielded. The transducer cable shield should be connected to the extension cable shield, which can then be grounded at the signal conditioner.

5. LOADING EFFECTS

An equivalent circuit of a piezoresistive transducer for use when considering loading effects is shown in Figure 5-4.

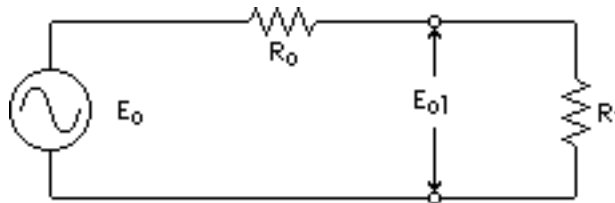

FIGURE 5-4: SCHEMATIC DIAGRAM OF LOADING EFFECTS

Referring to Figure 5-4:

R_o = output resistance of the bridge, including cable resistance.

E_o = sensitivity into an infinite load

E_{o1} = loaded output sensitivity

R_1 = load resistance

Using the equivalent circuit above, and the output resistance supplied on the calibration card, the effect of loading may be directly calculated:

$$E_{o1} = E_o \left(\frac{R_1}{R_o + R_1} \right)$$

Because the resistance of the strain-gage elements varies with temperature, output resistance must be measured at the operating temperature.

ENDEVCO PR PRESSURE TRANSDUCERS INSTRUCTION MANUAL

6. EFFECT OF CABLE ON SENSITIVITY

Each Endevco piezoresistive transducer is calibrated and supplied with a specified length of cable. When utilizing long cables in a particular application, three effects must be noted:

A. RESISTANCE

Resistance in the input (excitation) wires may significantly reduce the excitation voltage at the transducer, resulting in a loss of sensitivity. The new sensitivity is equal to:

$$E_{i1} = E_o \left(\frac{R_i}{R_i + 2R_{ci}} \right)$$

where R_i is the input resistance of the transducer and R_{ci} is the resistance of one excitation wire.

This effect may be overcome by using remote sensing leads (see Section 6.2).

B. ATTENUATION

Signal attenuation also results from resistance in the output wires. This attenuation may readily be calculated from the relation.

$$E_{o1} = E_o \left(\frac{R_1}{R_o + R_1 + 2R_{co}} \right)$$

where the terms are as defined in Section 5.5, and R_{co} is the resistance of one output wire between transducer and load.

C. RC FILTERING

RC filtering in the shielded instrument leads may attenuate the high-frequency components in the data signal. The stray and distributed capacitance present in the transducer and a short cable are such that any filtering effect is negligible. However, when long leads are connected between transducer and readout equipment, the response at higher frequencies may be significantly affected.

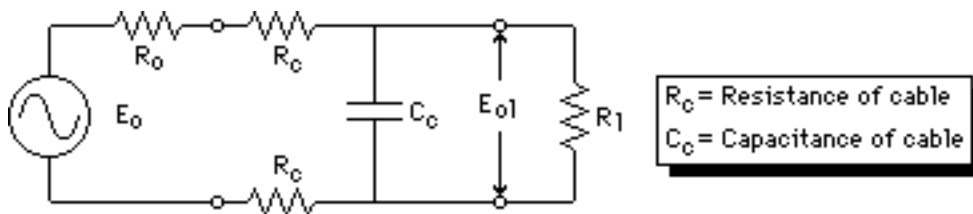

FIGURE 5-5: SCHEMATIC DIAGRAM OF SIMPLIFIED CIRCUIT WITH LONG CABLE

Because the resistance and capacitance is actually distributed along the cable, the circuit of Figure 5-5 only approximates the effect of long wires. It is suggested that each 1000 feet of cable be considered as a separate RC network. Terminating a long cable with a load equal to the characteristic impedance of the cable will usually improve system high frequency response. For precise measurements, line filtering action must be determined experimentally as part of the system calibration.

ENDEVCO PR PRESSURE TRANSDUCERS INSTRUCTION MANUAL

7. BALANCING ZERO MEASURAND OUTPUT

Using the integral compensation circuitry, during manufacture, Zero Measurand Output (ZMO) is adjusted to ± 10 mV maximum, and thermal zero shift is compensated to less than 3% of full scale output over the compensated temperature range.

If tighter tolerance is required, compensation or adjustment of the unbalanced output of a transducer (Zero Measurand Output) can easily be performed in the signal-conditioning equipment. For a full bridge transducer the balance potentiometer R_b is connected across the excitation terminals, and a current limiting resistor connected between the wiper arm of the potentiometer and the bridge as shown in Figure 5-6.

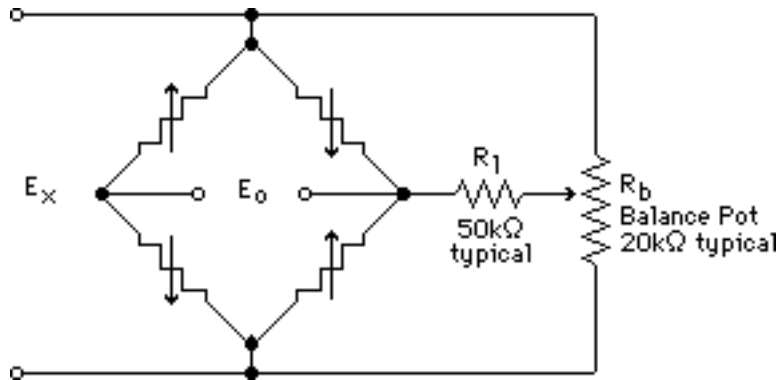

FIGURE 5-6: ZERO OUTPUT NETWORK FOR FULL-BRIDGE TRANSDUCER

8. MEASUREMENT OF DYNAMIC PRESSURES

In any dynamic measurement, the response of the transducer and the electronics must be considered. The requirement peculiar to pressure measurement is that one must consider the fluid coupling to the transducer from the measurement point. For example, when a transducer must be placed remote to a measurement point, the response of a pressure line can severely limit the response of the measurement system. When measuring pressure oscillations in the audio frequency even the selection and placement of a transducer at the measurement point can be critical. In addition to the dynamic characteristics of a transducer and its placement, the results are a function of certain qualities of the fluid. These are significantly different for gases and liquids.

The summaries below review some of the fundamental considerations from the standpoint of a pressure measurement.

A. ACOUSTIC FUNDAMENTALS

Sound Speed in Liquid - The speed of a compressional pulse in any homogeneous isotropic medium is:

$$c = \sqrt{\frac{K}{r}} \text{ where } K = \text{volume modulus} \\ r = \text{mass density}$$

ENDEVCO PR PRESSURE TRANSDUCERS INSTRUCTION MANUAL

The speed of sound in two commonly used liquids are:

Water = 4728 fps (1440 m/s) Alcohol = 4071 fps (1240 m/s)

For comparative purposes the speed of sound in steel is about 1800 fps (550 m/s).

Sound Speed in Gas - The speed of sound in a gas is:

$$c = \sqrt{g \frac{RT}{M}} \text{ where } c = \text{ speed}$$

g = ratio of the two principal specific heats of the gas
R = gas constant per mole
T = absolute temperature
M = molecular weight of the gas

From this we may conclude that the speed of sound in ideal gases depends only on the kind of gas and the temperature, and is wholly independent of changes in pressure.

If we denote c_t as the speed of sound in a given gas at temperature T and by C_0 the speed in the same gas at temperature T_0 , and apply the above equation, we have:

$$c_t = C_0 \frac{T}{T_0}$$

At 32°F (0°C), the speed of sound in dry air is 1088 fps (331.45 m/s) and the speed increases about 1 fps (0.6m/s) for each degree centigrade of rise in temperature. The speed of sound in several commonly used gases is:

at 60°F, Air	= 120 fps (341 m/s)
(15°C) Hydrogen	= 4170 fps (1270 m/s)
Carbon Dioxide	= 847 fps (258 m/s)

Organ Pipe Resonance - The wavelength of the fundamental wave is equal to four times the length of the pipe for a pipe which is open at one end and closed at the other end. Resonant excitation can be produced by the fundamental frequency and all the odd harmonics.

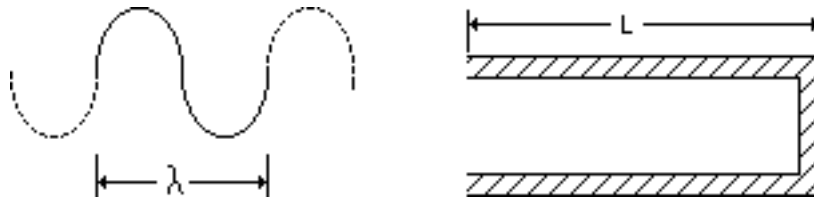

FIGURE 5-7: ORGAN PIPE RESONANCE

$$f_n = \frac{c}{4L}, \frac{3c}{4L}, \dots$$

f = frequency
c = speed of sound in the fluid
L = length of pipe

$$l = \frac{c}{f}$$

l = wavelength

ENDEVCO PR PRESSURE TRANSDUCERS INSTRUCTION MANUAL

Cavity Resonances (Helmholtz)

$$f_n = \frac{c}{2\pi} \sqrt{\frac{a}{lv}}$$

where: c = speed of sound in the fluid
 a = area of orifice
 l = length of orifice
 (much greater than diameter of orifice)
 v = volume of cavity

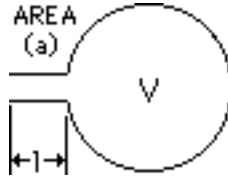

FIGURE 5-8: CAVITY RESONANCES -1

When the orifice has essentially no length, such as hole in a thin plate:

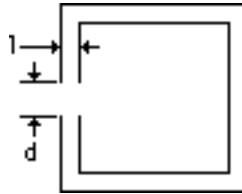

FIGURE 5-9: CAVITY RESONANCES-2

$$f = \frac{c}{2\pi} \sqrt{\frac{d}{v}}$$

Transmitting Tube Connected to Cavity

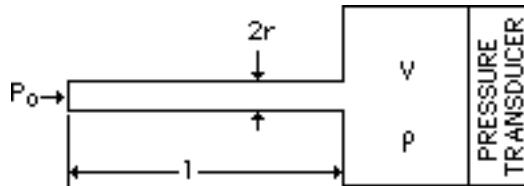

FIGURE 5-10: TRANSMITTING TUBE CONNECTED TO CAVITY

If the conventional formula for laminar friction resistance in tube flow is used to represent the damping of fluid motion, the resulting expression for pressure amplitude ratio is:

$$\left| \frac{P}{P_0} \right| = \frac{1}{\sqrt{\left[1 - \left(\frac{w}{wn}\right)^2 + 4h^2\left(\frac{w}{wn}\right)^2\right]}}$$

The natural frequency is:

ENDEVCO PR PRESSURE TRANSDUCERS INSTRUCTION MANUAL

$$\omega_n = \sqrt{\frac{3pr^2c^2}{4lv}}$$

The damping ratio (h) is:

$$h = \frac{2m}{rcr^3} \sqrt{\frac{3lv}{p}} \quad \text{where } m = \text{dynamic viscosity of fluid}$$

$r = \text{fluid density}$

When the tube diameter is very small (as in a capillary), it is possible to produce a very large damping ratio so that the equation for the pressure response will reduce to the following for frequencies below the natural frequencies:

$$\left| \frac{P}{P_0} \right| = \frac{1}{\sqrt{1 + 4h^2 \left(\frac{\omega}{\omega_n} \right)^2}}$$

B. ACOUSTIC LIMITATION OF A PRESSURE PROBE

Frequency response requirements are often greater than 500 Hz for the measurement of transient total pressure in gas paths of turbine engines. To measure this, small pressure transducers are placed in probes. To protect the transducer from particulate damage and to provide a more thermally benign environment it is sometimes desirable to place the transducer back from the front of the probe. (An extreme example is to measure this at the end of a capillary tube.) An example of such device is shown by Figure 5-11. Simply estimating the lowest resonance of this system by using the equations shown for organ pipes or for tubing/cavity combinations results in an answer of about 3000 Hz, far below the resonant frequency of the transducer diaphragm.

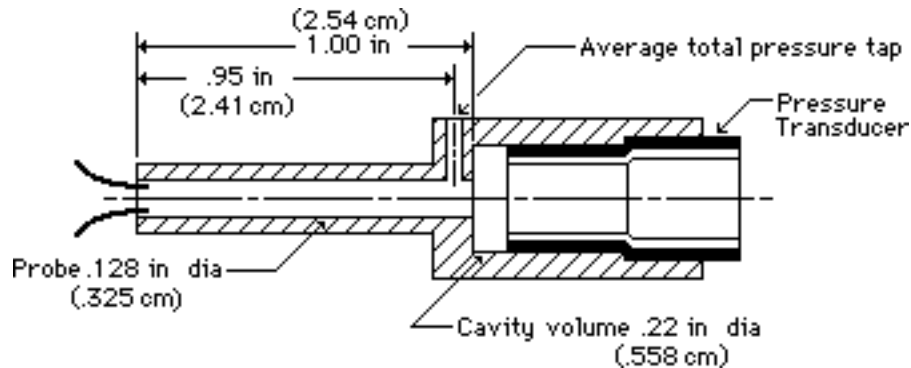

FIGURE 5-11: ACOUSTIC LIMITATIONS OF A PRESSURE PROBE

C. LOW FREQUENCY RESPONSE

Piezoresistive transducers are essentially single-degree-of-freedom systems. The use of a dc excited Wheatstone bridge allows the transducer to measure pressures from steady state (dc) to relatively high frequencies. As the electrical signal generating network is essentially resistive, the low frequency response at the transducer is unaffected by lead length and signal conditioning equipment impedances. As noted elsewhere, care must be taken in the selection of cable, cable length and signal-conditioning equipment.

ENDEVCO PR PRESSURE TRANSDUCERS INSTRUCTION MANUAL

SECTION 6: ELECTRONICS

1. DC POWER SUPPLIES

Most Endevco piezoresistive pressure transducers require a constant-voltage supply for excitation. A constant-current supply should not be used unless the transducer is specifically designed or compensated for operation in this mode. Because the typical four-element transducer may not be perfectly balanced or matched, variations in excitation voltage or current, including ripple, will result in an error output signal. It is necessary, therefore, that a stable and well-regulated power supply be employed.

A number of important characteristics must be considered in the selection of a suitable power supply. Among these are:

- A. Line Regulation
- B. Load Regulation
- C. Ripple and Noise
- D. Temperature Stability
- E. Time Stability
- F. dc Isolation

The output of the transducer is differential, so the signal conditioner input should not be grounded. This requires that the power supply be well insulated from ground. Not only must the power supply be well insulated to prevent dc leakage currents flowing through the transducer, but in addition ac coupling to ground and power line must be minimized to prevent line transients and dynamic ground loops from generating error signals. Recommended grounding point is at the signal conditioner output.

Endevco manufactures a series of instrument power supplies and signal conditioners. The characteristics of these instruments are optimized to meet the exacting requirements of strain-gage or piezoresistive transducers. See the list of Endevco power supplies and signal conditioners in the Signal Conditioner Section of your Endevco Catalog. For specific recommendations on Endevco equipment please contact the Endevco Field Engineer or representative in your area.

To calculate power supply requirements, the required current is calculated from

$$I_i = \frac{V_i}{R_i} \quad I_i = \text{Input current}$$

V_i = Excitation Voltage

R_i = Input Resistance

When powering more than one unit with a single power source, use the parallel combination of input resistance for all units used.

$$I_i = \frac{V_i}{R_C}$$

R_C = Parallel combination of Input Resistance

Typical current requirement is 6mA per transducer.

ENDEVCO PR PRESSURE TRANSDUCERS INSTRUCTION MANUAL

2. EXTERNAL SENSING

The voltage drop along long lines between a constant-voltage supply and transducer results in a reduced and sometimes unpredictable voltage at the transducer. Errors and spurious signals may appear at the transducer output due to variations in the resistance of these lines caused by temperature changes.

Many constant-voltage supplies provide for external voltage-sensing leads which connect directly to the transducer, independent of the power or excitation leads. Low current in the sensing leads reduces the voltage drop along these lines and the effects of changes in resistance. Thus, the voltage across the transducer is maintained constant and independent of resistance and current variations on the power leads.

3. SIGNAL CONDITIONING

Signal-conditioning equipment provides the advantages of combining a stable and isolated constant-voltage power supply with the necessary controls to "condition" the signal from the piezoresistive transducer. These instruments often feature plug-in mode cards which establish a specific mode of operation and calibration for a specified type of transducer.

Controls are usually available to perform:

- A. Bridge Zero Balance
- B. Excitation Adjustment
- C. Multipoint, Bipolar Shunt Calibration
- D. Zero Calibration
- E. Local Monitoring of Excitation and Data Signals
- G. Remote Control, to duplicate local calibration operations

Manually-controlled Endevco Model 106 two-channel bridge amplifier (requires external power supply such as Model 109) or Model 4428 (with integral power supply) provides a digital display and easy operation/setup with pressure transducers.

Endevco's Series 68200 CCAS™ system provides multi-channel, computer-controlled conditioning for bridge-type transducers (BCAS) as well as differential and single-ended charge mode, Isotron™, and velocity coil transducers.

Contact your local Endevco sales representative or Endevco World Headquarters for specific recommendations for the best amplifier/signal conditioner for your application.

4. AMPLIFIERS

In many applications, the output signal from a piezoresistive pressure transducer is large enough to require no amplification. However, amplifiers are sometimes necessary to provide gain, to match impedances, or to drive recording galvanometers.

The input impedance of an amplifier should be significantly larger than the output resistance of the connected transducer. See Section 5.5 for a discussion of the effect of load resistance on the sensitivity of a transducer. Differential-input amplifiers are required in order to provide isolation of both sides of the input signal. Differential amplifiers provide high common-mode rejection, which is required when the transducer is excited with a grounded power supply, (a) when one power supply provides excitation for a number of transducers, or (b) when external electrostatic or magnetic fields produce error signals at the input of the amplifier.

The frequency response of the amplifier must be adequate for the range of frequencies expected in the input, and the noise level should be well below the lowest signal to be measured. Other important characteristics to be considered in the selections of an amplifier are: Gain accuracy and stability, zero stability, and the effect of temperature on gain and zero.

ENDEVCO PR PRESSURE TRANSDUCERS INSTRUCTION MANUAL

The amplifiers included in Endevco signal conditioners are designed for optimum performance with Endevco transducers.

5. SYSTEMS

When exciting an unamplified pressure transducer, you may choose to ground one side of the excitation source, but do not ground either of the output leads. **DO NOT GROUND BOTH INPUT AND OUTPUT LEADS. GROUNDING BOTH SIDES WILL SHORT CIRCUIT ONE STRAIN GAGE, PRODUCING ERRONEOUS OUTPUT SIGNALS.** If floating both input and output of the pressure transducer, insure that common mode voltage of the power supply does not exceed 25V. Accidental short term application of excitation voltage to the output leads will not damage the transducer, but it should not be operated while connected backwards.

A. GROUND LOOPS

In addition to the characteristics of each component of the measurement system, the operation of the system as a whole must be considered. One particularly important system consideration is prevention of ground loops. The problem can occur when the common connection (or signal return) in the system is grounded at more than one point. Differences in earth potential up to several volts may exist between various grounding points. This potential difference can produce circulating ground currents, which result in noise and hum in the measuring system.

The only method of preventing ground loops is to ensure that the entire system is grounded at a single point. In general, the most satisfactory system ground point is at the readout input. (When several channels of data are being simultaneously fed to the same recorder, it is mandatory). This requires that transducer, power supply and amplifier be insulated from ground. In Figure 6-1, signal ground is connected to earth at only one point, at the readout.

The sensing elements of all Endevco pressure transducers are insulated from the mounting case. Grounding of the case to the test structure protects the sensing elements from external electrical fields. The cable shield should be connected to the signal ground at the signal conditioner. If the case is not grounded to the test structure, it should be connected to a nearby and convenient earth ground.

Matching electronics in which the case is tied to circuit ground can be satisfactorily isolated by wrapping with insulating material (electrical tape, etc.), or by simply placing it on paper or cardboard. (In severe environments, the amplifier can be wrapped with sponge rubber).

If amplifier output cables are unjacketed, care must be taken that any exposed shields or connectors do not become inadvertently grounded ahead of the recorder input.

ENDEVCO PR PRESSURE TRANSDUCERS
INSTRUCTION MANUAL

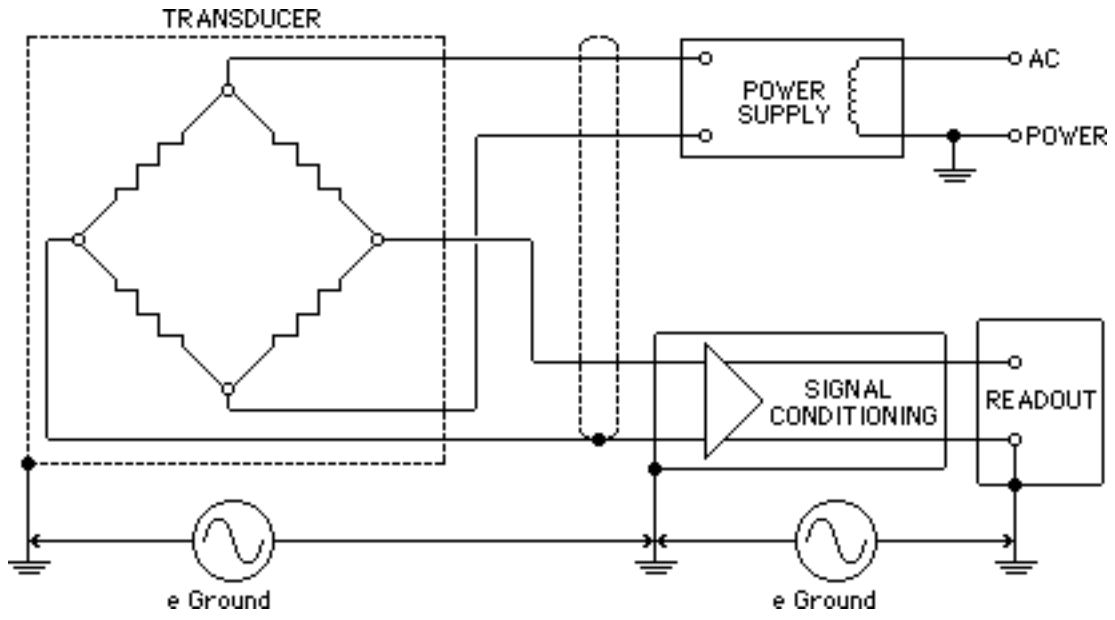

FIGURE 6-1: TYPICAL GROUND LOOP POTENTIALS

ENDEVCO PR PRESSURE TRANSDUCERS INSTRUCTION MANUAL

SECTION 7: CALIBRATION

1. INTRODUCTION

Complete calibration requires more than just determining the sensitivity at one or more values of input pressure. Endevco's unique capability of maintaining excellent linearity to three times "full scale" makes linearity and "overrange" performance of particular value. Endevco 100% tests, and supplies calibration data on the most important static input, electrical, and thermal characteristics. Dynamic characteristics are established by periodic sampling tests. All specifications and calibrations are in accordance with applicable ANSI and ISA standards.

2. STATIC CALIBRATIONS

Measurements are first made at zero pressure, then 3 times full scale, then zero, to establish zero shift after 3xFSO. Then two complete cycles from zero to full scale and return are performed, measuring output at 20% (or 25%) increments. These data points are used for calculation of nonlinearity, hysteresis, and nonrepeatability. Thermal sensitivity and thermal zero shift tests follow, with a final retest at room temperature.

All output measurements are made with 10.0 Vdc (+/-5mV) excitation applied. An explanation of terminology and measurements of performance characteristics used on transducer test reports is provided in Section 3.

Ranges up to 100 psi are calibrated on a computer-controlled automatic test console, using gas as the pressure medium. Ranges above 100 to 1,000 psi are calibrated manually using gas as the medium. Above 1,000 psi ranges are calibrated manually using hydraulic media. The calibration standards all have accuracies better than 0.01%.

Computer-controlled calibrations are performed at zero, and 20% increments of full scale to 100%. Manual calibrations are performed at zero and 25% increments of full scale. For transducers calibrated on the computer-controlled console, the computer calculates the test parameters, plots nonlinearity, thermal zero shift and thermal sensitivity shift, and prints out the test report. Data from the manual calibration operations is input to the computer, which then calculates parameters and prints the test report. In both cases the computer compares test data with stored specification limits and accepts or rejects each transducer.

Non-linearity is plotted against percent of full scale output, using straight lines to connect the actual measurement points.

Thermal zero shift and thermal sensitivity shift are plotted against temperature, using straight lines to connect the actual measurement points.

3. DYNAMIC CALIBRATIONS

Two important reasons for conducting dynamic pressure calibrations are (1) to evaluate the frequency response of a measurement system used in a dynamic application, and (2) to calibrate a self-generating transducer, such as a piezoelectric device, which cannot be calibrated statically. To complete this calibration either a continuous wave (periodic) input or transient input (step, pulse, etc.) can be used. Calibration uncertainties for both of these approaches are much larger than for the static calibration approaches.

Extensive design evaluations have indicated that Endevco pressure transducer designs exhibit very flat low frequency response (from steady state to a few percent of resonant frequency) and classical, undamped, single-degree-of-freedom response to near the resonant frequency. The Q of the frequency response curve is dependent on the pressure medium. Structural damping of the silicon diaphragm is extremely low.

ENDEVCO PR PRESSURE TRANSDUCERS INSTRUCTION MANUAL

A. GAS SHOCK TUBES

Small shock tubes are often used to provide rise time and frequency response characteristics for transducers. Because of difficulties in determining the pressure level in the step, shock tubes are not usually used for pressure sensitivity calibration. Pressure rise times of about 1 microsecond are practical which permits transducer characterization to frequencies beyond 100,000 Hz. Endevco uses shock tubes to determine frequency response of all designs.

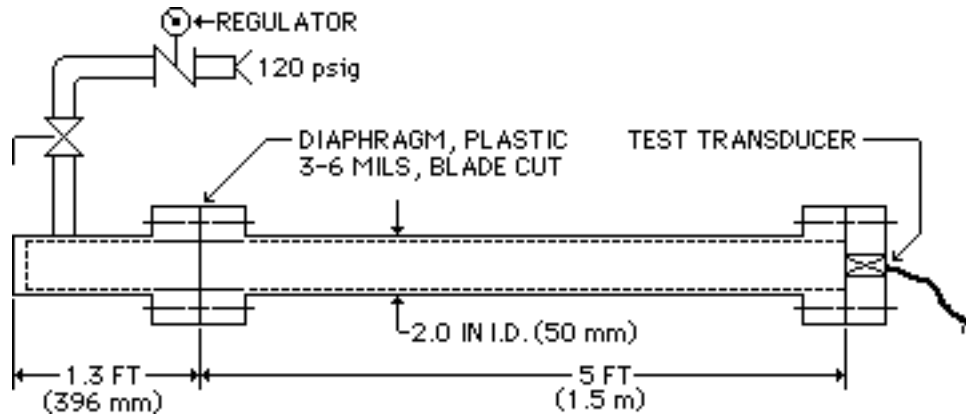

FIGURE 7-1: PRESSURE SHOCK TUBE

ENDEVCO PR PRESSURE TRANSDUCERS INSTRUCTION MANUAL

SECTION 8: CHECK LIST

1. INTRODUCTION

The successful gathering of data in dynamic pressure measurements requires the proper selection of components used in the system, and their proper installation. The following checks are provided as an aid in setting up valid test systems.

2. MEASUREMENT SYSTEM INSTALLATION CHECKLIST

Transducer:

Is the unit in good condition and ready to use?

Check:

- Up-to-Date Calibration
- Physical Condition
- Case Condition
- Mounting Threads
- Resistance
- Vent Tube Clear

Cable :

Will the cable operate satisfactorily in the measurement environment?

Check:

- Temperature Range of Environment
- Outgassing Limitations

Will the cable characteristics provide the desired data accuracy?

Check:

- Cable Lead Resistance
- Size and Weight
- Flexibility
- Sealed Connection
- Cable Capacitance

Is the cable in good condition and ready for use?

Check:

- Physical Condition
- Cable Kinked, Crushed?
- Continuity
- Insulation Resistance

Power Supply:

Will the power supply operate satisfactorily in the measurement environment?

Check:

- Temperature Range
- Maximum Shock and Vibration

ENDEVCO PR PRESSURE TRANSDUCERS INSTRUCTION MANUAL

- Humidity
- Pressure
- Acoustic Level
- Corrosive Gases
- Magnetic and RF Fields
- Nuclear Radiation
- Salt Spray

Is this the proper power supply for the application?
Check:

- Load Regulation
- Line Regulation
- Temperature Stability
- Time Stability
- Ripple and Noise
- Output Impedance
- Line-Transient Response
- Noise-to-Ground
- DC Isolation
- Remote Sensing/Regulation

Is the unit in good condition and ready to use?
Check:

- Up-to-date Calibration
- Inspect for Physical Damage
- Connectors
- Case
- Output cables
- Inspect for Clean Connectors
- Mode Card, if required

Amplifier:

Will the amplifier operate satisfactorily in the measurement environment?
Check:

- Temperature Range
- Maximum Shock and Vibration
- Humidity
- Pressure
- Acoustic Level
- Corrosive Gases
- Magnetic and RF Fields
- Nuclear Radiation
- Salt Spray

Is this the proper amplifier for the application?
Check:

- Long Output Lines?
- Need for Power Amplifier
- Airborne?
- Need for Solid-State Potted Amplifier
- Zero Balance Range

ENDEVCO PR PRESSURE TRANSDUCERS INSTRUCTION MANUAL

Will the amplifier characteristics provide the desired data accuracy?

Check:

- Gain
- Gain Stability
- Gain-Temperature Coefficient
- Frequency Response
- Linearity
- Phase Shift
- Output Current and Voltage
- Residual Noise
- Input Impedance
- Transient Response
- Overload Capability
- Common-Mode rejection
- Zero Stability
- Zero-Temperature Coefficient

Is the amplifier in good condition and ready to use?

Check:

- Up-to-Date Calibration
- Inspect for Physical Damage
- Connectors
- Case
- Output Cables
- Inspect for Clean Connectors

Readout:

Does the remainder of the system, including any additional amplifier, filters, and readout devices, introduce any limitation that will tend to degrade the transducer-amplifier characteristics?

Check:

All of previous check items, plus adequate resolution.

ENDEVCO PR PRESSURE TRANSDUCERS INSTRUCTION MANUAL

SECTION 9: MAINTENANCE AND WARRANTY

1. RECEIVING INSPECTION AND TROUBLE SHOOTING

Immediately upon receipt of the Pressure Transducer, it should be checked at room temperature to insure proper operation, and to validate the warranty. Three very simple tests can be conducted without removing the Pressure Transducer from its shipping and storage container:

A. IMPEDANCE TEST

Open the Pressure Transducer container, unwind a few inches of leads. Leave the Pressure Transducer securely mounted in its container. Read the input impedance (Red to Black) and output impedance (Green to White) with an ohmmeter. Consult the pressure transducer test report to determine proper value of impedance. IF THE VALUE OF IMPEDANCE IS NOT WITHIN $\pm 25\%$ OF THE SPECIFIED VALUE, CONTACT ENDEVCO IMMEDIATELY. Your transducer may be damaged. Input and output impedance are very sensitive to temperature, so they may vary significantly from room temperature values provided on the test report.

B. INSULATION RESISTANCE

If input and output impedances are within acceptable limits use a megohmmeter, ohmmeter, or multimeter set at 50 volts maximum, measure insulation resistance between:

1. All leads connected together and the cable shield
2. All leads connected together and the transducer case
3. Cable shield and transducer case

All three readings should be 100 megohms minimum.

C. ZMO

After the impedance and insulation resistance tests, still leaving the transducer in its box, remove any protective cover from the diaphragm and clear it from contact with the box. Apply the specified excitation voltage to the transducer and measure its output with a DC millivolt meter. Allow the transducer to warm-up for a few minutes. The transducer should have a zero offset value within the data sheet specification for PSIG (gauge pressure) and PSID (differential pressure) units. For PSIA units (absolute) the reading should be equal to the Calibrated Sensitivity (mV/psia) x local atmospheric pressure plus the data sheet ZMO specification. If a PSIA unit had a sensitivity of 6 mV/psi, a reading of 88.2 mV plus the ZMO specification would be acceptable for 14.7 psi atmospheric.

If any of these initial checks do not give proper readings, indicating a possible malfunction, and if you cannot find the reason for the erroneous reading, call Endevco and provide the data over the telephone, or contact us by letter. With this information, we can usually determine whether the Pressure Transducer is faulty or whether there is a wiring mistake in the external instrumentation.

2. TRANSDUCER MAINTENANCE

CAUTION: Care must be taken while handling piezoresistive transducers. Typical Endevco transducers are designed to give many years of service without maintenance, when operated within specification limits. Transducers that behave erratically should be first checked for plugged protective screen. The protective screen should be kept clear at all times. Do NOT attempt to clear the screen with a needle, wire, or other hard pointed object. The screen may be damaged, or the diaphragm may be broken. Endevco recommends rinsing the screen with acetone. Do not use an ultrasonic cleaner, the high frequencies generated may damage some transducers by exciting the resonance of their diaphragms. If acetone does not clear the screen satisfactorily, try to determine the

ENDEVCO PR PRESSURE TRANSDUCERS INSTRUCTION MANUAL

composition of the contaminant and use a suitable solvent. Rinsing with any commonly used industrial solvent will not damage the transducer. However, DO NOT SOAK in ANY solvent or water.

If the transducer behaves erratically and the screen is clear, check for open circuits in the bridge. Repeat the Receiving Inspection tests for input and output impedance and insulation resistance.

3. RECALIBRATION

Recalibrations of sensitivity and ZMO should be performed at 6-12 month intervals, depending upon usage. Ordinarily, recalibrations need be performed only at 12 month intervals if it is known that the transducer has not been used beyond its rated specifications. If the transducer is used under severe environments, it may be desirable to use shorter recalibration intervals. In some cases, it is also desirable to recalibrate in the laboratory or field prior to the start of extensive tests. In these cases, calibration just prior to conducting the test is warranted, particularly if previous history of usage of the transducer is not well known.

Resistance calibration need normally be performed only once. If, however, there is some evidence that the transducer may have been damaged, sensitivity, ZMO and resistance measurements should be performed to determine the nature and extent of any possible damage.

If calibration facilities are not available, units may be returned to Endevco for recalibration at nominal charge. This recalibration includes sensitivity, resistance, temperature and other measurements. Data is provided on a standard calibration certificate.

4. CABLE MAINTENANCE

Transducers with broken integral cables may be repaired by splicing (see 5.4.B).

5. WARRANTY

Endevco warrants each new instrument to be free from defects in material and workmanship for one year from date of sale to the original purchaser. This warranty does not extend to units which have been misused or used in violation of Endevco recommendations, nor to units which have been altered or repaired outside Endevco's factory. Defects covered by this warranty will be remedied at no charge, provided the instrument is delivered to the factory with all transportation charges prepaid. If upon examination it is found that the defect is not within the scope of this warranty, a statement of repair charges and a request for authorization to proceed will be submitted.

6. RETURN OF EQUIPMENT

All equipment being returned to Endevco, regardless of warranty, should be shipped transportation charges prepaid, to the attention of Technical Service Department, Endevco, 30700 Rancho Viejo Road, San Juan Capistrano, CA 92675. A statement describing the observed malfunction should accompany the shipment.

ENDEVCO PR PRESSURE TRANSDUCERS INSTRUCTION MANUAL

APPENDIX A: GLOSSARY

1. GLOSSARY

ABSOLUTE PRESSURE: The pressure measured relative to a perfect vacuum.

ABSOLUTE PRESSURE TRANSDUCER: A transducer that has an internal reference chamber sealed at or close to 0 psia (full vacuum).

ACCURACY: The ratio of the error to the output or to the full scale output, as specified, expressed in percent.

BRIDGE: A Wheatstone bridge configuration utilizing four resistive elements.

BRIDGE RESISTANCE: See input impedance and output impedance.

BURST PRESSURE: The maximum pressure which may be applied without rupture.

CALIBRATION: The comparison of transducer voltage outputs against the outputs of a reference standard.

COMMON MODE PRESSURE: See Line Pressure.

CONSTANT CURRENT: Electric current independent of either voltage or resistances, and fixed at a specific value.

DAMPING: The reduction of response at the resonant frequency through the use of a damping medium such as oil. Usually specified as the ratio of critical damping.

DEAD VOLUME: The volume inside the pressure port of a transducer.

DEFLECTION: The change in length along the primary axis or distance a diaphragm moves at the center between no-load and rated load conditions.

DIAPHRAGM: The sensing membrane which is deformed when pressure is applied.

DIFFERENTIAL PRESSURE: The difference in pressure between two measurement points.

ENDEVCO: An acronym for ENgineering DEvelopment COmpany; A leader in developing instrumentation for the sensing of physical phenomena. A Division of Allied Signal Corporation.

EXCITATION, ELECTRICAL: The voltage or current applied to the input terminals of the transducer.

FLUSH DIAPHRAGM: Sensing element is located on the tip of the transducer (No pressure port).

FREQUENCY RESPONSE: The range of frequencies over which the transducer voltage output will follow the sinusoidally varying mechanical input within specified limits.

FULL SCALE: The maximum measurand that a transducer is designed to measure within its specification.

FULL SCALE OUTPUT: The algebraic difference between the output with zero input and output with full scale input (range) applied.

GAGE PRESSURE; The pressure above (or below) atmospheric. Represents positive difference between measured pressure and existing atmospheric pressure. Can be converted to absolute by adding actual atmospheric pressure value.

ENDEVCO PR PRESSURE TRANSDUCERS INSTRUCTION MANUAL

GAGE PRESSURE TRANSDUCER: A transducer which measures pressure relative to the atmospheric pressure.

HYSTERESIS: The maximum difference between output readings for the same measurand point, one point obtained while increasing from zero and the other while decreasing from full scale. The points are taken on the same continuous cycle. The deviation is expressed as a percent of full scale.

INDEPENDENT LINEARITY: Maximum deviation from the linear regression line (least squares fit) for all measured points, expressed as percent of full scale output.

INPUT IMPEDANCE: The resistance measured across the excitation terminals of a transducer at room temperature.

INSULATION (ISOLATION) RESISTANCE: The DC resistance expressed in ohms measured between any electrical connector pin or lead wire and the transducer body or case. Normally measured at 50 Vdc.

LINEARITY: The maximum deviation of the calibration curve from a specified straight line expressed as a percent of full scale output and measured on increasing measurand only.

LINE PRESSURE: The maximum pressure in the pressure vessel or pipe for differential pressure measurement. Also called Common Mode Pressure.

MEASURAND : The physical quantity, property, or condition which is measured. (e.g.: pressure, load, weight, acceleration).

MEDIUM, MEDIA: The fluid, in contact with the diaphragm, the pressure of which is being measured.

NON-LINEARITY: Used interchangeably with "linearity."

NON-REPEATABILITY: Used interchangeably with "repeatability."

OUTPUT: The electrical signal measured at the output terminals which is produced by an applied input to a transducer.

OUTPUT IMPEDANCE: The resistance as measured on the output terminals of a transducer at standard temperature, with no measurand applied, and with the excitation terminals open-circuited.

OVERRANGE: The maximum pressure or load which may be applied to the transducer without causing a permanent change in the performance specifications.

PASCAL: Pressure of one Newton (force) per square meter.

PHASE SHIFT: The phase angle between the output and the applied signal.

PROOF PRESSURE: The maximum pressure which may be applied without changing transducer performance characteristics.

PSI: Pounds per square inch.

PSIA: Pounds per square inch absolute.

PSID: Pounds per square inch differential.

PSIG: Pounds per square inch gage.

RANGE: The measurand values, over which a transducer is intended to measure, specified by their upper and lower limits.

ENDEVCO PR PRESSURE TRANSDUCERS INSTRUCTION MANUAL

REPEATABILITY: The ability of a transducer to reproduce output readings when the same measurand value is applied to it consecutively, under the same conditions, and in the same direction. Repeatability is expressed as the maximum difference between output readings as a percent of full scale.

RESOLUTION: A measure of ability to delineate, detail or distinguish between nearly equal values of a quantity. Also referred to as "threshold" - lowest level of valid measurement.

RISE TIME: The time required for the output of a transducer to rise from 10% to 90% of its final value as a result of a step change of measurand.

SENSING ELEMENT: The part of the transducer which reacts directly in response to the measurand.

SENSITIVITY: The ratio of change in transducer output to a change in the value of the measurand.

SHUNT CAL: The change in electrical output caused by placing a fixed resistor between the appropriate transducer terminals. Used "in the field" for quick calibration.

SPAN: The algebraic difference between the limits of the range from zero to full scale.

SPECIFICATIONS: The group of error limits within which each device will operate.

STRAIN GAGE: A measuring element for converting mechanical strain into an electrical signal.

SUPPLY VOLTAGE: See "Excitation."

TEMPERATURE COEFFICIENT: The percentage change in the sensitivity of a transducer as a result of a change in the operating temperature of the transducer (expressed as percent per degree ($\%/^{\circ}\text{F}$)).

TEMPERATURE, COMPENSATED: The range of temperature over which a transducer can operate up to full scale and still meet all specifications. Endevco pressure transducers incorporate temperature compensation.

TEMPERATURE COMPENSATION: The utilization of supplementary devices, materials, or components with the transducer to minimize sources of error caused by changing temperature.

TEMPERATURE, OPERATING: The range of temperature over which a transducer may be safely operated up to full scale without causing failure; but specifications may not be met.

THERMAL SENSITIVITY SHIFT: The change in rated output due to a change in ambient temperature. Usually expressed as the maximum percentage change in rated output.

THERMAL ZERO SHIFT: The change in zero balance due to a change in ambient temperature. Usually expressed as the maximum percentage change of FSO over the compensated temperature range.

TRANSDUCER: A device (or medium) that converts energy from one form to another. The term is generally applied to devices that take a physical phenomenon (pressure, temperature, humidity, flow, etc.) and convert it to an electrical signal.

ZERO ADJUSTMENTS: Used when "setting up" a transducer to adjust the output signal to zero when zero load/pressure is applied.

ZERO BALANCE: The output signal of the transducer with rated excitation and with no-load applied, usually expressed in millivolts. Also called Zero Measurand Output (ZMO) and zero pressure output.

ENDEVCO PR PRESSURE TRANSDUCERS INSTRUCTION MANUAL

ZERO MEASURAND OUTPUT: See ZERO BALANCE.

ZERO RETURN: The difference in zero balance measured immediately before rated load application of specified duration and measured after removal of the load, and when the output has stabilized.

**ENDEVCO PR PRESSURE TRANSDUCERS
INSTRUCTION MANUAL**

**APPENDIX B:
PRESSURE CONVERSION CHART**

1. PRESSURE CONVERSION CHART (Multiplication Factors)

FROM	PSI	PASCAL	BAR	MILLIBAR	IN. Hg	IN. H ₂ O	mm Hg	mm H ₂ O	ATM	kg/cm ²
TO										
PSI	1	1.4504E-4	14.504	1.4504E-2	0.49118	3.6127E-2	1.9337E-2	1.4223E-3	14.696	14.223
PASCAL	6.8946E+3	1	1E+5	100	3.3865E+3	249.08	133.32	9.8068	1.0132E+5	9.8067E+4
BAR	6.8946E-2	1E-5	1	1E-3	3.3865E-2	2.4908E-3	1.3332E-3	9.8068E-5	1.0132	0.98068
MILLIBAR	68.946	1E-2	1E+3	1	33.865	2.4908	1.3332	9.8068E-2	1.0312E+3	9.8068E+2
IN. Hg	2.0359	2.9529E-4	29.529	2.9529E-2	1	7.3552E-2	3.9368E-2	2.8959E-3	29.920	28.959
IN. H ₂ O	27.680	4.0147E-3	401.47	0.40147	13.596	1	0.53525	3.9372E-2	406.78	393.72
mm Hg	51.714	7.5006E-3	750.06	0.75006	25.401	1.8683	1	7.3558E-2	760.00	7.3559E+2
mm H ₂ O	703.05	0.10197	1.0197E+4	10.197	345.32	25.399	13.595	1	1.0332E+4	1E+4
ATM	6.8045E-2	9.8692E-6	0.98692	9.8692E-4	3.3422E-2	2.4583E-3	1.3158E-3	9.6788E-5	1	0.9678
kg/cm ²	7.0305E-2	1.0197E-5	1.0197	1.0197E-3	3.4531E-2	2.5399E-3	1.3595E-3	1E-4	1.0332	1

NOTE: TORR is the same as mm Hg absolute. The conversion factors for TORR and mm Hg are identical.