



Model EX611A00
Charge Output Accelerometer
Installation and Operating Manual

**For assistance with the operation of this product,
contact PCB Piezotronics, Inc.**

Toll-free: 800-828-8840
24-hour SensorLine: 716-684-0001
Fax: 716-684-0987
E-mail: info@pcb.com
Web: www.pcb.com



Repair and Maintenance

PCB guarantees Total Customer Satisfaction through its “Lifetime Warranty Plus” on all Platinum Stock Products sold by PCB and through its limited warranties on all other PCB Stock, Standard and Special products. Due to the sophisticated nature of our sensors and associated instrumentation, **field servicing and repair is not recommended and, if attempted, will void the factory warranty.**

Beyond routine calibration and battery replacements where applicable, our products require no user maintenance. Clean electrical connectors, housings, and mounting surfaces with solutions and techniques that will not harm the material of construction. Observe caution when using liquids near devices that are not hermetically sealed. Such devices should only be wiped with a dampened cloth—never saturated or submerged.

In the event that equipment becomes damaged or ceases to operate, our Application Engineers are here to support your troubleshooting efforts 24 hours a day, 7 days a week. Call or email with model and serial number as well as a brief description of the problem.

Calibration

Routine calibration of sensors and associated instrumentation is necessary to maintain measurement accuracy. We recommend calibrating on an annual basis, after exposure to any extreme environmental influence, or prior to any critical test.

PCB Piezotronics is an ISO-9001 certified company whose calibration services are accredited by A2LA to ISO/IEC 17025, with full traceability to SI through N.I.S.T. In addition to our standard calibration services, we also offer specialized tests, including: sensitivity at elevated or cryogenic temperatures, phase response, extended high or low frequency response, extended range, leak testing, hydrostatic pressure testing, and others. For more information, contact your local PCB Piezotronics distributor, sales representative, or factory customer service representative.

Returning Equipment

If factory repair is required, our representatives will provide you with a Return Material Authorization (RMA) number, which we use to reference any information you have already provided and expedite the repair process. This number should be clearly marked on the outside of all returned package(s) and on any packing list(s) accompanying the shipment.

Contact Information

PCB Piezotronics, Inc.
3425 Walden Ave.
Depew, NY14043 USA
Toll-free: (800) 828-8840
24-hour SensorLine: (716) 684-0001
General inquiries: info@pcb.com
Repair inquiries: rma@pcb.com

For a complete list of distributors, global offices and sales representatives, visit our website, www.pcb.com.

Safety Considerations

This product is intended for use by qualified personnel who recognize shock hazards and are familiar with the precautions required to avoid injury. While our equipment is designed with user safety in mind, the protection provided by the equipment may be impaired if equipment is used in a manner not specified by this manual.

Discontinue use and contact our 24-Hour Sensorline if:

- Assistance is needed to safely operate equipment
- Damage is visible or suspected
- Equipment fails or malfunctions

For complete equipment ratings, refer to the enclosed specification sheet for your product.

Definition of Terms and Symbols

The following symbols may be used in this manual:



DANGER

Indicates an immediate hazardous situation, which, if not avoided, may result in death or serious injury.

**CAUTION**

Refers to hazards that could damage the instrument.

**NOTE**

Indicates tips, recommendations and important information. The notes simplify processes and contain additional information on particular operating steps.

The following symbols may be found on the equipment described in this manual:



This symbol on the unit indicates that high voltage may be present. Use standard safety precautions to avoid personal contact with this voltage.



This symbol on the unit indicates that the user should refer to the operating instructions located in the manual.



This symbol indicates safety, earth ground.



PCB工业监视和测量设备 - 中国RoHS2公布表

PCB Industrial Monitoring and Measuring Equipment - China RoHS 2 Disclosure Table

部件名称	有害物质					
	铅 (Pb)	汞 (Hg)	镉 (Cd)	六价铬 (Cr(VI))	多溴联苯 (PBB)	多溴二苯醚 (PBDE)
住房	0	0	0	0	0	0
PCB板	X	0	0	0	0	0
电气连接器	0	0	0	0	0	0
压电晶体	X	0	0	0	0	0
环氧	0	0	0	0	0	0
铁氟龙	0	0	0	0	0	0
电子	0	0	0	0	0	0
厚膜基板	0	0	X	0	0	0
电线	0	0	0	0	0	0
电缆	X	0	0	0	0	0
塑料	0	0	0	0	0	0
焊接	X	0	0	0	0	0
铜合金/黄铜	X	0	0	0	0	0
本表格依据 SJ/T 11364 的规定编制。						
0：表示该有害物质在该部件所有均质材料中的含量均在 GB/T 26572 规定的限量要求以下。						
X：表示该有害物质至少在该部件的某一均质材料中的含量超出 GB/T 26572 规定的限量要求。						
铅是欧洲RoHS指令2011/65/ EU附件三和附件四目前由于允许的豁免。						

CHINA RoHS COMPLIANCE

Component Name	Hazardous Substances					
	Lead (Pb)	Mercury (Hg)	Cadmium (Cd)	Chromium VI Compounds (Cr(VI))	Polybrominated Biphenyls (PBB)	Polybrominated Diphenyl Ethers (PBDE)
Housing	O	O	O	O	O	O
PCB Board	X	O	O	O	O	O
Electrical Connectors	O	O	O	O	O	O
Piezoelectric Crystals	X	O	O	O	O	O
Epoxy	O	O	O	O	O	O
Teflon	O	O	O	O	O	O
Electronics	O	O	O	O	O	O
Thick Film Substrate	O	O	X	O	O	O
Wires	O	O	O	O	O	O
Cables	X	O	O	O	O	O
Plastic	O	O	O	O	O	O
Solder	X	O	O	O	O	O
Copper Alloy/Brass	X	O	O	O	O	O

This table is prepared in accordance with the provisions of SJ/T 11364.

O: Indicates that said hazardous substance contained in all of the homogeneous materials for this part is below the limit requirement of GB/T 26572.

X: Indicates that said hazardous substance contained in at least one of the homogeneous materials for this part is above the limit requirement of GB/T 26572.

Lead is present due to allowed exemption in Annex III or Annex IV of the European RoHS Directive 2011/65/EU.

	ENGLISH	SI	
Performance			
Sensitivity(± 5 %)	10 pC/g	1.02 pC/(m/s ²)	
Measurement Range	± 200 g pk	± 1,962 m/s ² pk	
Frequency Range(± 5 %)	2.8 kHz	2.8 kHz	[1]
Frequency Range(+ 10 %)	3.7 kHz	3.7 kHz	[1]
Resonant Frequency	≥ 17 kHz	≥ 17 kHz	
Non-Linearity	≤ 1 %	≤ 1 %	[2]
Transverse Sensitivity	≤ 5 %	≤ 5 %	[3]
Environmental			
Overload Limit(Shock)	± 5,000 g pk	± 49,050 m/s ² pk	
Temperature Range	-65 to +1200 °F	-54 to +650 °C	[4]
Temperature Range	-165 to +1300 °F	-109 to +704 °C	[5]
Temperature Response	See Graph	See Graph	[6]
Base Strain Sensitivity	0.033 g/με	0.32 (m/s ²)/με	[6]
Radiation Exposure Limit(Integrated Neutron Flux)	1 E10 N/cm ²	1 E10 N/cm ²	
Radiation Exposure Limit(Integrated Gamma Flux)	1 E8 rad	1 E8 rad	
Hazardous Area Approval	Ex ia IIC T6... T 710°C Ga	Ex ia IIC T6... T 710°C Ga	
Hazardous Area Approval	IECEX Ex ia IIC T6... T 710°C Ga	IECEX Ex ia IIC T6... T 710°C Ga	
Electrical			
Capacitance(Pin to Pin)	250 pF	250 pF	[6]
Capacitance(Pin to Case)	110 pF	110 pF	[6]
Capacitance(Unbalance Between Pins)	≤ 2 pF	≤ 2 pF	
Insulation Resistance(Pin to Case 70° F)	> 10 ⁹ Ohm	> 10 ⁹ Ohm	[6]
Insulation Resistance(Pin to Pin 70° F)	> 10 ⁹ Ohm	> 10 ⁹ Ohm	
Output Polarity	Differential	Differential	
Physical			
Sensing Element	UHT-12™	UHT-12™	
Sensing Geometry	Shear	Shear	
Housing Material	Inconel	Inconel	
Sealing	Hermetic	Hermetic	
Size (Height x Length x Width)	.787 in x 1.465 in x 1.456 in	20 mm x 37 mm x 37 mm	
Weight(without cable)	6.3 oz	180 gm	[6]
Electrical Connector	7/16-27 2-Pin	7/16-27 2-Pin	
Electrical Connection Position	Side	Side	
Mounting	Through Holes (4)	Through Holes (4)	
Cable Length	10 ft	3.05 m	
Cable Type	MI Hardline Cable	MI Hardline Cable	

OPTIONAL VERSIONS

Optional versions have identical specifications and accessories as listed for the standard model except where noted below. More than one option may be used.

NOTES:

[1] Low frequency response is determined by external signal conditioning electronics.
 [2] Zero-based, least-squares, straight line method.
 [3] Transverse sensitivity is typically <= 3%.
 [4] Continuous
 [5] Extreme
 [6] Typical.
 [7] See PCB Declaration of Conformance PS122 for details.

SUPPLIED ACCESSORIES:

Model 081A115 M6 x 1 x 25 mm long (4)
 Model ACS-1 NIST traceable frequency response (10 Hz to upper 5% point).

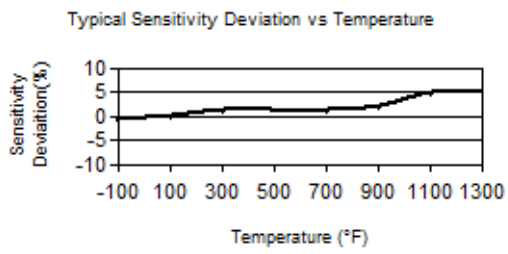

All specifications are at room temperature unless otherwise specified.
 In the interest of constant product improvement, we reserve the right to change specifications without notice.
 ICP® is a registered trademark of PCB Piezotronics, Inc.

Entered: LK	Engineer: NJF	Sales: EGY	Approved: NJF	Spec Number:
Date: 01/08/2021	Date: 01/08/2021	Date: 01/08/2021	Date: 01/08/2021	57531

PCB PIEZOTRONICS

3425 Walden Avenue, Depew, NY 14043

Phone: 716-684-0001
 Fax: 716-684-0987
 E-Mail: info@pcb.com

57532

PCB Piezotronics Inc. claims proprietary rights in the information disclosed hereon. Neither it nor any reproduction thereof will be disclosed to others without the written consent of PCB Piezotronics Inc.

REVISIONS		
REV	DESCRIPTION	DIN
A	UPDATED CABLE LENGTH	42350

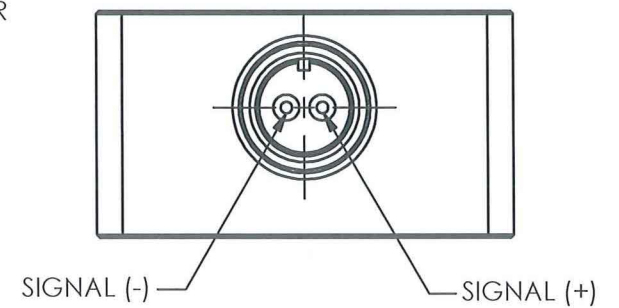
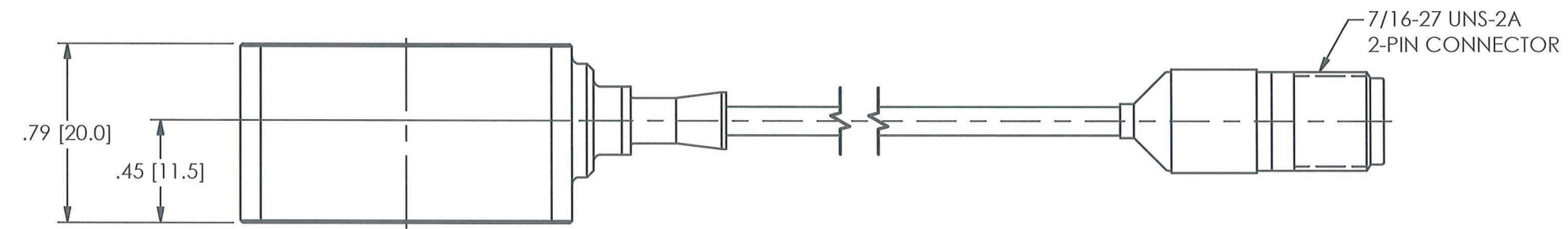
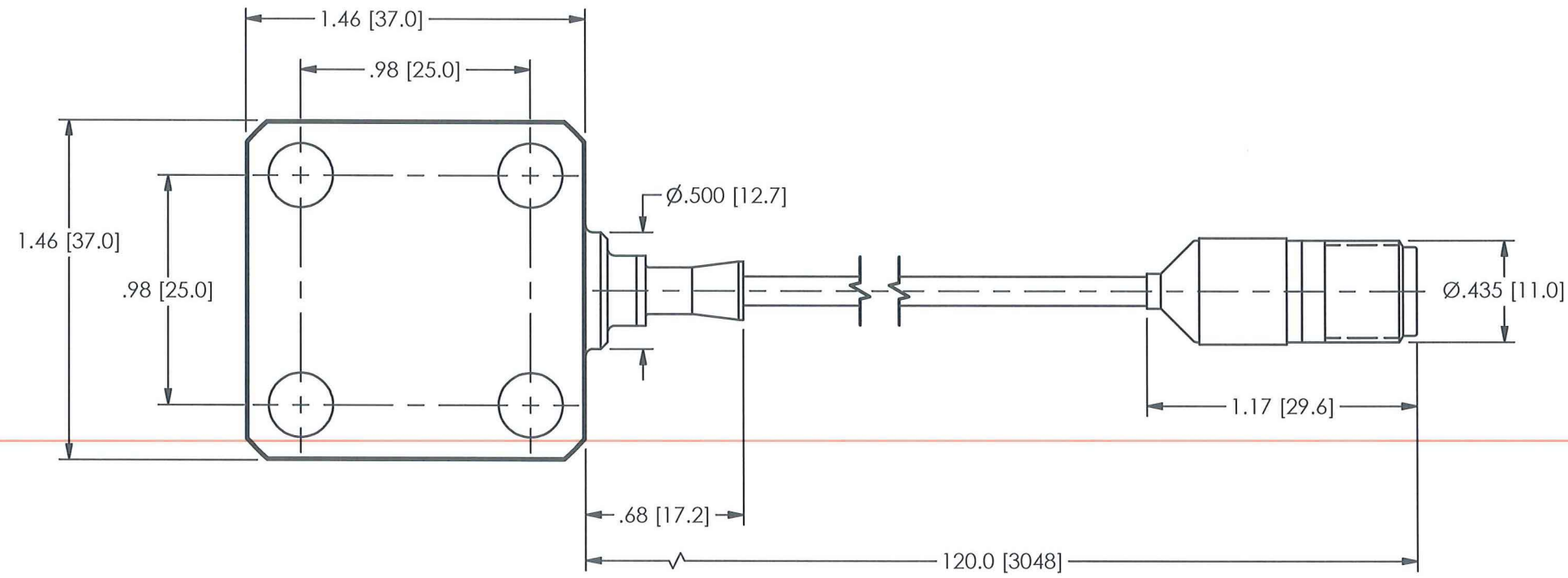

UNLESS OTHERWISE SPECIFIED TOLERANCES ARE:		DRAWN	CHECKED	ENGINEER	
DIMENSIONS IN INCHES	DIMENSIONS IN MILLIMETERS [IN BRACKETS]	JDM	12/27/13	JDG	
DECIMALS XX ±.03 XXX ±.010	DECIMALS X ± 0.8 XX ± 0.25	TITLE			3425 WALDEN AVE. DEPEW, NY 14043 (716) 684-0001 E-MAIL: sales@pcb.com
ANGLES ± 2 DEGREES	ANGLES ± 2 DEGREES	OUTLINE DRAWING MODEL EX611A00			CODE IDENT. NO. 52681
FILLETS AND RADII .003 - .005	FILLETS AND RADII 0.07 - 0.13				DWG. NO. 57532
					SCALE: 1.5X SHEET 1 OF 1

PCB Piezotronics Inc. claims proprietary rights in the information disclosed hereon. Neither it nor any reproduction thereof will be disclosed to others without the written consent of PCB Piezotronics Inc.

64270

SCHEDULE DRAWING

NO MODIFICATIONS PERMITTED WITHOUT REFERENCE TO THE NOTIFIED BODY

REVISIONS

REV	DESCRIPTION	DIN
NR	RELEASED TO DRAFTING	45417

5 Ci AND Li BASED ON CABLE WITH 30 pF/ft AND .33 μH/ft WITH A MAXIMUM CABLE LENGTH OF 100ft. Ci AND Li WILL BE DECREASED WITH SHORTER CABLE LENGTHS.

4 SHIELDS TO BE EARTHED AT BARRIER END.

3 THE INSTALLER SHALL INSURE THAT THE TRANSDUCER MOUNTING STRUCTURE IS AT THE SAME GROUNDING POTENTIAL AS THE BARRIER GROUND. TOTAL EARTH LOOP IMPEDANCE SHALL BE LESS THAN ONE OHM.

2 BARRIER WILL BE MOUNTED IN AN ENCLOSURE THE SUITABILITY OF WHICH WILL BE DETERMINED BY LOCAL AUTHORITIES.

1 ENTITY APPLICATION:

<u>Barrier</u>	<u>I.S. Apparatus</u>
Voc/Uo	< V /Ui
Isc/Io	I /Ii
Ca/Co	Ci + C
La/Lo	Li + L
Po	< Pi (CENELEC ONLY)

BARRIERS WITHIN THE SPECIFIED LIMITATIONS ARE PERMITTED.

ENTITY PARAMETERS:

- Ui = 30 V
- Ii 100 mA
- Pi 0.7 W
- 5 Ci 3300 pF
- 5 Li 30 μH

CERTIFIED BY THE APPROPRIATE APPROVAL AUTHORITY FOR CONNECTION TO THE FOLLOWING AREAS:

- ZONE 0
 - Exia IIC
 - AExia IIC
- DIV 1
 - CLASS I, GROUPS A,B,C,D
 - CLASS II, GROUPS E,F,G
 - CLASS III

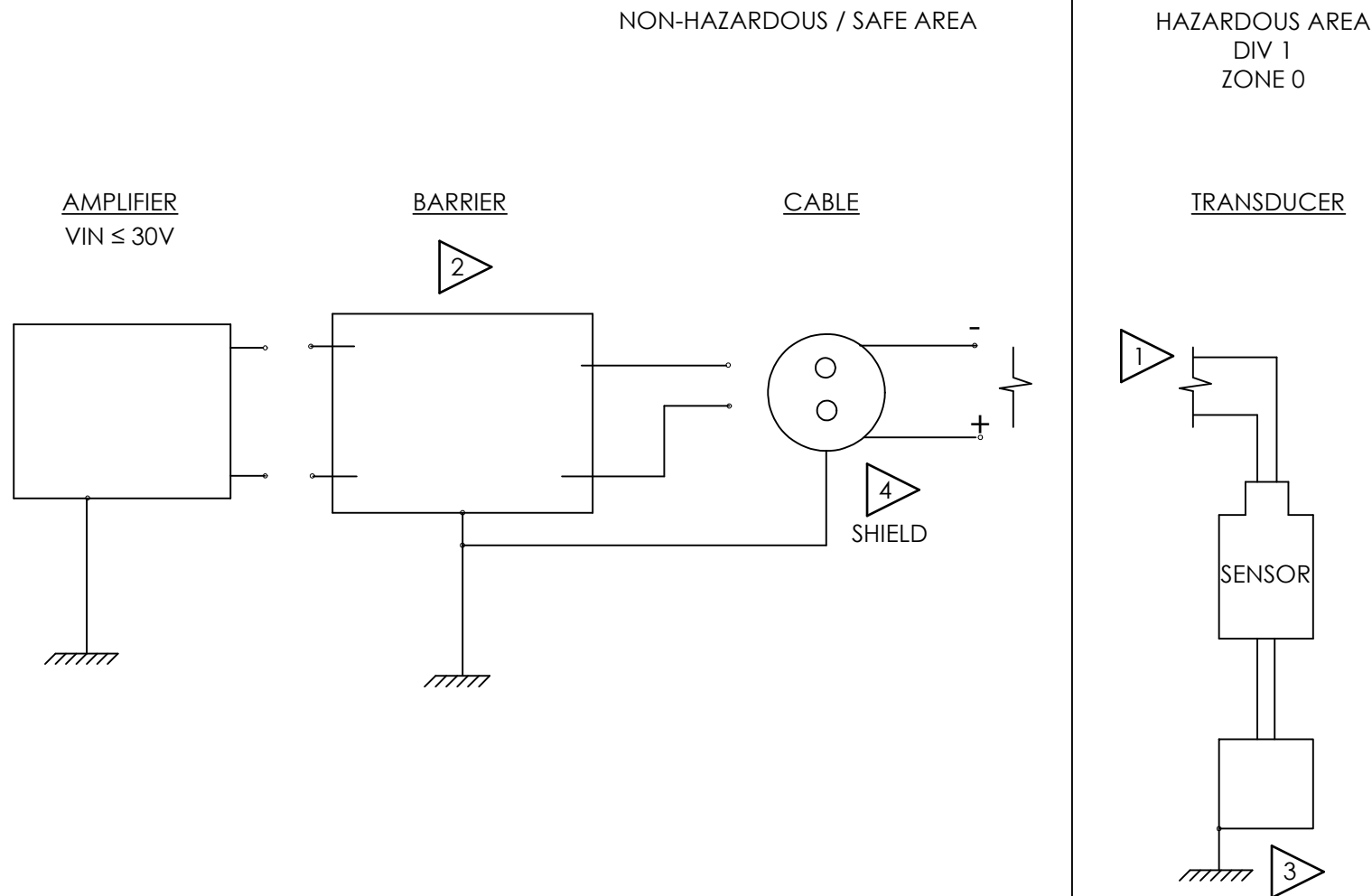

NO CHANGES WITHOUT CSA APPROVAL

UNLESS OTHERWISE SPECIFIED	
DIMENSIONS ARE IN INCHES	
DECIMALS	X ± .05
	XX ± .01
	XXX ± .005
	XXXX ± .0005
ANGLES ± 2 DEGREES	
FILLETS AND RADII .003 - .005	
HEX DIMENSIONS ARE:	
	≤ .5 + .000 / - .003
	> .5 + .000 / - .005
INTERNAL THREAD DEPTH MIN.	
REMOVE ALL BURRS	
SHARP = R.000 - R.003	



DRAWN	CHECKED	ENGINEER
JDM 5/3/16	ECB 5/3/16	GGG 5/3/16
TITLE		
CSA APPROVAL		
EX611 SERIES		
INTERCONNECTIONS		

PCB PIEZOTRONICS™
 3425 WALDEN AVE. DEPEW, NY 14043
 (716) 684-0002 E-MAIL: sales@pcb.com

CODE IDENT. NO. 52681	DWG. NO. 64270
SCALE: NONE	SHEET 1 OF 1



Certificate of Compliance

Certificate: 70089987

Master Contract: 184981 (103164_0_000)

Project: 70089987

Date Issued: 2016-08-09

Issued to: Industrial Monitoring Instr. (IMI)
A Div. of PCB Piezotronics, Inc.
3425 Walden Ave
Depew, New York 14043
USA
Attention: Carrie Termin

The products listed below are eligible to bear the CSA Mark shown with adjacent indicators 'C' and 'US' for Canada and US or with adjacent indicator 'US' for US only or without either indicator for Canada only.



Issued by: Konstantin Rybalko
Konstantin Rybalko

PRODUCTS

CLASS - C225804 - PROCESS CONTROL EQUIPMENT-Intrinsically Safe, Entity - For Hazardous Locations-

CLASS - C225884 - PROCESS CONTROL EQUIPMENT - Intrinsically Safe, Entity-- For Hazardous Locations - Certified to US Standards

Class I, Div. 1, Group A, B, C & D;

Class II, Div. 1, Group E, F & G;

Class III, Div. 1;

Ex ia IIC T6 – T710, Ga;

Class I, Zone 0, AEx ia IIC T6 – T710, Ga

Models EX611XYY/(M)NNNZZ High Temperature Vibration Sensor; intrinsically safe with entity parameters as shown below; must be installed as per installation drawing 64270; temperature code as shown below. Ambient temperature –196°C to +700°C



Certificate: 70089987
Project: 70089987

Master Contract: 184981
Date Issued: 2016-08-09

Entity Parameters	Temperature Code
Ui / Vmax = 30V	T6 (-196°C to +80°C)
Ii / Imax = 100mA	T5 (-196°C to +95°C)
Pi / Pmax = 0.7W	T4 (-196°C to 130°C)
Ci = 3300nF	T3 (-196°C to 195°C)
Li = 30μH	T2 (-196°C to 290°C)
	T1 (-196°C to 440°C)
	T710 (-196°C to 700°C)

Notes:

1. For Canadian Installations, sensor case must be bonded to ground according to Section 18-182 of the CEC, Part 1.
2. For US Installations, sensor case must be bonded to ground according to Article 501.16 of the NEC.

APPLICABLE REQUIREMENTS

- CSA-C22.2 No. 0-10 (R2015) - General requirements – Canadian Electrical Code, Part II
- C22.2 No. 61010-1-12 - Safety requirements for electrical equipment for measurement, control, and laboratory use – Part 1: General requirements
- ANSI/UL 61010-1 3rd Ed. - Electrical Equipment for Measurement, Control, and Laboratory Use; Part 1: General Requirements
- C22.2 No. 60079-0: 2015 - Explosive atmospheres – Part 0: Equipment – General requirements
- ANSI/UL 60079-0 6th Ed. - Explosive atmospheres – Part 0: Equipment – General requirements
- C22.2 No. 60079-11: 2014 - Explosive atmospheres – Part 11: Equipment protection by intrinsic safety “i”
- ANSI/UL 60079-11 6th Ed. - Explosive atmospheres – Part 11: Equipment protection by intrinsic safety “i”



Supplement to Certificate of Compliance

Certificate: 70089987

Master Contract: 184981 (103164_0_000)

*The products listed, including the latest revision described below,
are eligible to be marked in accordance with the referenced Certificate.*

Product Certification History

Project	Date	Description
70089987	2016-08-09	Certification of EX611 Series High Temperature Vibration Sensor.



LCIE

ATTESTATION D'EXAMEN UE DE TYPE EU TYPE EXAMINATION CERTIFICATE



1 Version : 01

LCIE 12 ATEX 3053 X

Issue : 01

Directive 2014/34/UE

Directive 2014/34/EU

2 Appareil ou Système de Protection destiné à être utilisé en Atmosphères Explosibles

Equipment or Protective System Intended for use in Potentially Explosive Atmospheres

3 Produit :
Capteurs de vibrations

Product :
Vibration sensors

Type: EX611**/*******

4 Fabricant :

Manufacturer :

PCB Piezotronics

5 Adresse :

Address :

3425 Walden Avenue
Depew, New York 14043
USA

6 Ce produit et ses variantes éventuelles acceptées sont décrits dans l'annexe de la présente attestation et dans les documents descriptifs cités en référence.

This product and any acceptable variations thereto are specified in the schedule to this certificate and the documents therein referred to.

7 Le LCIE, Organisme Notifié sous la référence 0081 conformément à l'article 17 de la directive 2014/34/UE du Parlement européen et du Conseil du 26 février 2014, certifie que ce produit est conforme aux Exigences Essentielles de Sécurité et de Santé pour la conception et la construction de produits destinés à être utilisés en atmosphères explosibles, données dans l'annexe II de la Directive.

LCIE, Notified Body number 0081 in accordance with article 17 of the Directive 2014/34/EU of the European Parliament and the Council of 26 February 2014 certifies that product has been found to comply with the Essential Health and Safety Requirements relating to the design and construction of products intended for use in potentially explosive atmospheres, given in Annex II to the Directive.

Les résultats des vérifications et essais figurent dans le(s) rapport(s) confidentiel(s) N° :

The examination and test results are recorded in confidential report(s) N°:

113365-625323, 157330-726954

8 Le respect des Exigences Essentielles de Sécurité et de Santé est assuré par la conformité à :

Compliance with the Essential Health and Safety Requirements has been assured by compliance with :

EN 60079-0:2012+A11:2013 ; EN 60079-11:2012

9 Le signe « X » lorsqu'il est placé à la suite du numéro de l'attestation, indique que cet appareil est soumis aux conditions particulières d'utilisation, mentionnées dans l'annexe de cette attestation.

If the sign "X" is placed after the certificate number, it indicates that the product is subject to the Specific Conditions of Use specified in the schedule to this certificate.

10 Cette Attestation d'Examen UE de Type concerne uniquement la conception et la construction du produit spécifié. Des exigences supplémentaires de la directive sont applicables pour la fabrication et la fourniture du produit. Ces dernières ne sont pas couvertes par la présente attestation.

This EU Type Examination Certificate relates only to the design and construction of the specified product. Further requirements of the Directive apply to the manufacturing process and supply of this product. These are not covered by this certificate.

11 Le marquage du produit est mentionné dans l'annexe de cette attestation.

The marking of the product is specified in the schedule to this certificate.

Fontenay-aux-Roses, le 31 janvier 2019

Responsable de Certification

Certification Officer

Julien Gauthier

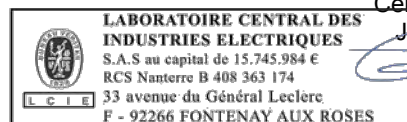

Seul le texte en français peut engager la responsabilité du LCIE. Ce document ne peut être reproduit que dans son intégralité, sans aucune modification. Il est établi en accord avec le [référentiel de certification ATEX](#) du LCIE. *The LCIE's liability applies only on the French text. This document may only be reproduced in its entirety and without any change. It is issued in accordance with LCIE's [ATEX Certification Rules](#).*
CERT-ATEX-FORM 04 Rev. 05

12 DESCRIPTION DU PRODUIT

L'équipement est un capteur de vibration basé sur une technologie de cristal piézo-électrique (capacité ≤ 300 pF).
 Les séries EX611***/***** sont des capteurs haute température avec, soit uniquement une sortie par connecteur, soit un câble intégral équipé d'un connecteur de sortie.
 Le capteur de vibration fournit un signal lorsqu'il est soumis à un mouvement.
 Le capteur est fabriqué en acier inoxydable, avec une tête carrée ou triangulaire selon les modèles concernés.

DETAILS DE LA GAMME

Capteurs de vibrations sont de type :

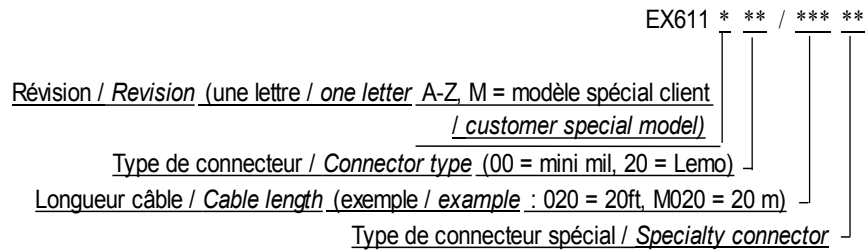

CARACTERISTIQUES

Paramètres électriques pour tous modèles avec connecteurs seuls ou avec câbles équipés de connecteurs de sortie (100 ft maximum) :

U_i : 30V, I_i : 100mA, P_i : 0,7W, C_i : 3300pF, L_i : 33 μ H.

MARQUAGE

Le marquage du produit doit comprendre :

- Marquage complet :
- PCB Piezotronics Inc. ou IMI Sensors ou IMI
 Adresse : ...
 Type : EX611***/***** (1)
 N° de fabrication : ...
 Année de fabrication : ...
-  Ex II 1 G
 Ex ia IIC T6...T710°C Ga (2)
 LCIE 12 ATEX 3053 X
 -196°C $\leq T_{amb}$ \leq +700°C
 U_i : 30V, I_i : 100mA, P_i : 0,7W, C_i : 3300pF, L_i : 33 μ H

- Marquage réduit :
- PCB Piezotronics Inc. ou IMI Sensors ou IMI
 Type : EX611***/***** (1)
 N° de fabrication : ...
-  Ex II 1 G
 Ex ia IIC T6...T710°C Ga (2)
 LCIE 12 ATEX 3053 X
 U_i : 30V, I_i : 100mA, P_i : 0,7W, C_i : 3300pF, L_i : 33 μ H
 (1) complété avec le modèle de la gamme
 (2) température côté capteur et câble

DESCRIPTION OF PRODUCT

The equipment is a vibration sensor based on a piezo-electric crystal as sensing element (capacitance ≤ 300 pF).
 EX611***/***** series apparatus are high temperature sensors with either only an output connector, or with an integral cable and output connector.
 The vibration sensors provide a charge output when subjected to a mechanical motion.
 The sensors have stainless steel housings, with square base or triangular base mounting according to the models concerned.

RANGE DETAILS

Vibration sensors types are as following:

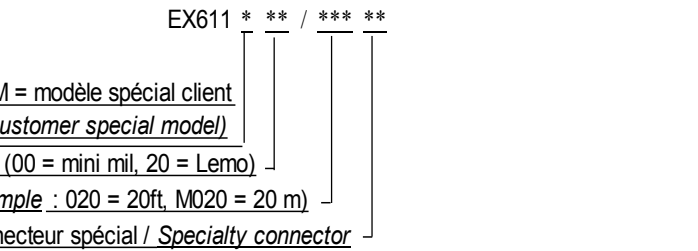

RATINGS

Electrical parameters for all models with either only an output connector, either an integral cable with output signal (100 ft maximum):

U_i : 30V, I_i : 100mA, P_i : 0.7W, C_i : 3300pF, L_i : 33 μ H.

MARKING

The marking of the product shall include the following :

- Complete marking :
- PCB Piezotronics Inc. or IMI Sensors or IMI
 Address : ...
 Type : EX611***/***** (1)
 Serial number : ...
 Year of construction : ...
-  Ex II 1 G
 Ex ia IIC T6...T710°C (2)
 LCIE 12 ATEX 3053 X
 -196°C $\leq T_{amb}$ \leq +700°C
 U_i : 30V, I_i : 100mA, P_i : 0.7W, C_i : 3300pF, L_i : 33 μ H

- Reduced marking :
- PCB Piezotronics Inc. or IMI Sensors or IMI
 Type : EX611***/***** (1)
 Serial number : ...
-  Ex II 1 G
 Ex ia IIC T6...T710°C (2)
 LCIE 12 ATEX 3053 X
 U_i : 30V, I_i : 100mA, P_i : 0.7W, C_i : 3300pF, L_i : 33 μ H
 (1) completed by the range model
 (2) temperature sensor and cable side

Seul le texte en français peut engager la responsabilité du LCIE. Ce document ne peut être reproduit que dans son intégralité, sans aucune modification. Il est établi en accord avec le [référentiel de certification ATEX](#) du LCIE. The LCIE's liability applies only on the French text. This document may only be reproduced in its entirety and without any change. It is issued in accordance with LCIE's [ATEX Certification Rules](#).
 CERT-ATEX-FORM 04 Rev. 05 Page 2 / 4

MARQUAGE (suite)

L'appareil doit également comporter le marquage normalement prévu par les normes de construction qui le concernent sous la responsabilité du fabricant.

MARKING (continued)

The equipment shall also bear the usual marking required by the product standards applying to such equipment under the manufacturer responsibility.

13 CONDITIONS PARTICULIERES D'UTILISATION

- a) Température ambiante d'utilisation : de - 196°C à + 700°C.
- b) Classement en température :

T6 : $-196^{\circ}\text{C} \leq T_{\text{amb}} \leq +80^{\circ}\text{C}$,
 T5 : $-196^{\circ}\text{C} \leq T_{\text{amb}} \leq +95^{\circ}\text{C}$,
 T4 : $-196^{\circ}\text{C} \leq T_{\text{amb}} \leq +130^{\circ}\text{C}$,
 T3 : $-196^{\circ}\text{C} \leq T_{\text{amb}} \leq +190^{\circ}\text{C}$,
 T2 : $-196^{\circ}\text{C} \leq T_{\text{amb}} \leq +290^{\circ}\text{C}$,
 T1 : $-196^{\circ}\text{C} \leq T_{\text{amb}} \leq +440^{\circ}\text{C}$,
 T710°C : $-196^{\circ}\text{C} \leq T_{\text{amb}} \leq +700^{\circ}\text{C}$.

SPECIFIC CONDITIONS OF USE

Ambient temperature range: from - 196°C to + 700°C.
 Temperature classification:

- c) L'appareil ne peut être raccordé qu'à des équipements certifiés de sécurité intrinsèque. Ces associations doivent répondre aux exigences de la norme EN 60079-25 (voir plan n°52744).
- d) Les câbles utilisés doivent avoir une température d'utilisation supérieure aux classements en température indiqués en fonction des températures ambiantes d'utilisation.

The apparatus can be only connected to intrinsically safe certified equipment. These combinations shall comply with the requirements of the standard EN 60079-25 (see drawing n°52744).

Cables used shall have operating temperature greater than temperature classification mentioned according to operating temperature range.

14 EXIGENCES ESSENTIELLES DE SANTE ET DE SECURITE

Couvertes par les normes listées au point 8.

ESSENTIAL HEALTH AND SAFETY REQUIREMENTS

Covered by standards listed at 8.

15 DOCUMENTS DESCRIPTIFS

N°	Description	Reference	Rev.	Date	Page(s)
1.	Dossier technique ATEX / <i>Technical file ATEX</i>	52740	A	2018/07/12	11
2.	Manuel d'instruction / <i>Instruction notice</i>	69820	-	-	2

DESCRIPTIVE DOCUMENTS

16 INFORMATIONS COMPLEMENTAIRES

Essais individuels

Néant

Conditions de certification

Les détenteurs d'attestations d'examen UE de type doivent également satisfaire les exigences de contrôle de production telles que définies à l'article 13 de la Directive 2014/34/UE.

En accord avec l'Article 41 de la Directive 2014/34/UE, les attestations d'examen CE de type mentionnant la Directive 94/9/CE émises avant la date d'application de la Directive 2014/34/UE (20 avril 2016) peuvent être considérées comme émises en accord avec la Directive 2014/34/UE. Les nouvelles versions de ces attestations peuvent conserver le numéro de l'attestation d'origine émise avant le 20 avril 2016.

ADDITIONAL INFORMATION

Routine tests

None

Conditions of certification

Holders of EU type examination certificates are also required to comply with the production control requirements defined in article 13 of Directive 2014/34/EU.

In accordance with Article 41 of Directive 2014/34/EU, EC-Type Examination Certificates referring to Directive 94/9/EC that were in existence prior to the date of application of Directive 2014/34/EU (20 April 2016) may be referenced as if they were issued in accordance with Directive 2014/34/EU. New issues of such certificates may continue to bear the original certificate number issued prior to 20 April 2016.

17 DETAILS DES MODIFICATIONS DE L'ATTESTATION

Version 00 : Evaluation selon les normes EN 60079-0:2009 30/08/2012 et EN 60079-11:2012.

DETAILS OF CERTIFICATE CHANGES

Issue 00 : Assessment according to EN 60079-0:2009 and 2012/08/30 EN 60079-11: 2012 standards.

1 Version : 01

LCIE 12 ATEX 3053 X

Issue : 01

17 **DETAILS DES MODIFICATIONS DE L'ATTESTATION
(suite)**

- Version 01 :
- Mise à jour normative selon la norme EN 60079-0:2012 + A11:2013.
 - Ajout d'un modèle plus petit de base triangulaire
 - IMI devient PCB Piezotronics.

**DETAILS OF CERTIFICATE CHANGES
(continued)**

- Issue 01:
- Normative update according to EN 60079-0:2012 + A11:2013 standard.
 - Addition of a smaller model with triangular base
 - IMI becomes PCB Piezotronics.

Seul le texte en français peut engager la responsabilité du LCIE. Ce document ne peut être reproduit que dans son intégralité, sans aucune modification. Il est établi en accord avec le [référentiel de certification ATEX](#) du LCIE. *The LCIE's liability applies only on the French text. This document may only be reproduced in its entirety and without any change. It is issued in accordance with LCIE's [ATEX Certification Rules](#).*

CERT-ATEX-FORM 04 Rev. 05

Page 4 / 4



LCIE

1 ATTESTATION D'EXAMEN CE DE TYPE

2 **Appareil ou système de protection** destiné à être utilisé en atmosphères explosibles (**Directive 94/9/CE**)

3 Numéro de l'attestation d'examen CE de type
LCIE 12 ATEX 3053 X

4 Appareil ou système de protection :
Capteurs de vibrations
Type : EX611xxx/xxxxx

5 Demandeur : IMI
Adresse : A PCB Piezotronics Div.
3425 Walden Avenue
Depew, New York, 14043 USA

6 Fabricant : IMI
Adresse : A PCB Piezotronics Div.
3425 Walden Avenue
Depew, New York, 14043 USA

7 Cet appareil ou système de protection et ses variantes éventuelles acceptées sont décrits dans l'annexe de la présente attestation et dans les documents descriptifs cités en référence.

8 Le LCIE, organisme notifié sous la référence 0081 conformément à l'article 9 de la directive 94/9/CE du Parlement européen et du Conseil du 23 mars 1994, certifie que cet appareil ou système de protection est conforme aux exigences essentielles de sécurité et de santé pour la conception et la construction d'appareils et de systèmes de protection destinés à être utilisés en atmosphères explosibles, données dans l'annexe II de la directive. Les résultats des vérifications et essais figurent dans le rapport confidentiel N°113365-625323.

9 Le respect des exigences essentielles de sécurité et de santé est assuré par la conformité à :

EN 60079-0:2009, EN 60079-11:2012

10 Le signe X lorsqu'il est placé à la suite du numéro de l'attestation, indique que cet appareil ou système de protection est soumis aux conditions spéciales pour une utilisation sûre, mentionnées dans l'annexe de la présente attestation.

11 Cette attestation d'examen CE de type concerne uniquement la conception et la construction de l'appareil ou du système de protection spécifié, conformément à l'annexe III de la directive 94/9/CE.

Des exigences supplémentaires de la directive sont applicables pour la fabrication et la fourniture de l'appareil ou du système de protection. Ces dernières ne sont pas couvertes par la présente attestation.

12 Le marquage de l'appareil ou du système de protection doit comporter les informations détaillées au point 15.

Fontenay-aux-Roses, le 30 août 2012

1 EC TYPE EXAMINATION CERTIFICATE

2 **Equipment or protective system** intended for use in potentially explosive atmospheres (**Directive 94/9/EC**)

3 EC type examination certificate number
LCIE 12 ATEX 3053 X

4 Equipment or protective system :
Vibration sensors
Type : EX611xxx/xxxxx

5 Applicant : IMI
Address : A PCB Piezotronics Div.
3425 Walden Avenue
Depew, New York, 14043 USA

6 Manufacturer : IMI
Address : A PCB Piezotronics Div.
3425 Walden Avenue
Depew, New York, 14043 USA

7 This equipment or protective system and any acceptable variation thereto are specified in the schedule to this certificate and the documents therein referred to.

8 LCIE, notified body number 0081 in accordance with article 9 of the Directive 94/9/EC of the European Parliament and the Council of 23 March 1994, certifies that this equipment or protective system has been found to comply with the essential Health and Safety Requirements relating to the design and construction of equipment and protective systems intended for use in potentially explosive atmospheres, given in Annex II to the Directive. The examination and test results are recorded in confidential report N°113365-625323.

9 Compliance with the Essential Health and Safety Requirements has been assured by compliance with :

EN 60079-0:2009, EN 60079-11:2012

10 If the sign X is placed after the certificate number, it indicates that the equipment or protective system is subject to special conditions for safe use specified in the schedule to this certificate.

11 This EC type examination certificate relates only to the design and construction of this specified equipment or protective system in accordance with annex III to the directive 94/9/EC.

Further requirements of the directive apply to the manufacturing process and supply of this equipment or protective system. These are not covered by this certificate.

12 The marking of the equipment or protective system shall include information as detailed at 15.

Le Responsable de Certification ATEX
ATEX Certification Officer

Michel BRENON
LCIE

Seul le texte en français peut engager la responsabilité du LCIE. Ce document ne peut être reproduit que dans son intégralité, sans aucune modification.
The LCIE's liability applies only on the French text. This document may only be reproduced in its entirety and without any change



L C I E

13 ANNEXE

14 ATTESTATION D'EXAMEN CE DE TYPE

LCIE 12 ATEX 3053 X

15 DESCRIPTION DE L'APPAREIL OU DU SYSTEME DE PROTECTION

Capteurs de vibrations
Type : EX611xxx/xxxxx

L'appareil est un capteur de vibration haute température avec un câble intégré et une sortie par connecteur.

Le capteur de vibration fournit un signal lorsqu'il est soumis à un mouvement.

Le capteur est fabriqué en acier inoxydable.

Paramètres spécifiques du ou des modes de protection concernés :

$U_i \leq 30V$, $I_i \leq 100mA$, $P_i \leq 0,7W$, $C_i \leq 3300pF$, $L_i \leq 30\mu H$

Le marquage doit être :

IMI Adresse :

Type : 611xxx/xxxxx (1)

N° de fabrication : ... Année de fabrication : ...

Ex II 1G Ex ia IIC T6...T710°C Ga (2)

LCIE 12 ATEX 3053 X

$U_i \leq 30V$, $I_i \leq 100mA$, $P_i \leq 0,7W$, $C_i \leq 3300pF$, $L_i \leq 30\mu H$

(1)complété avec le modèle

(2)température coté capteur et câble

L'appareil doit également comporter le marquage normalement prévu par les normes de construction qui le concerne.

16 DOCUMENTS DESCRIPTIFS

Dossier technique n°52740 rev.NR du 03/08/2012.

Ce document comprend 5 rubriques (7 pages).

17 CONDITIONS SPECIALES POUR UNE UTILISATION SÛRE

L'appareil ne peut être raccordé qu'à des équipements certifiés de sécurité intrinsèque. Ces associations doivent être compatibles vis-à-vis de la sécurité intrinsèque (voir les paramètres électriques au paragraphe 15 et le plan n°52744).

Température ambiante d'utilisation : - 196°C à + 700°C.

Classement en température : T6 à +80°C, T5 à +95°C, T4 à +130°C, T3 à +190°C, T2 à +290°C, T1 à +440°C, T710°C à +700°C.

18 EXIGENCES ESSENTIELLES DE SECURITE ET DE SANTE

Couvertes par les normes listées au point 9.

19 VERIFICATIONS ET ESSAIS INDIVIDUELS

Néant.

20 CONDITIONS DE CERTIFICATION

Les détenteurs d'attestations d'examen CE de type doivent également satisfaire les exigences de contrôle de production telles que définies à l'article 8 de la directive 94/9/CE.

13 SCHEDULE

14 EC TYPE EXAMINATION CERTIFICATE

LCIE 12 ATEX 3053 X

15 DESCRIPTION OF EQUIPMENT OR PROTECTIVE SYSTEM

Vibration sensors
Type : EX611xxx/xxxxx

The apparatus is a vibration sensor, series high temperature sensor with integral cable and connector output.

The vibration sensors provide a charge output when subjected to mechanical motion.

The sensors have stainless steel housings.

Specific parameters of the concerned protection mode:

$U_i \leq 30V$, $I_i \leq 100mA$, $P_i \leq 0,7W$, $C_i \leq 3300pF$, $L_i \leq 30\mu H$

The marking shall be :

IMI Address : ...

Type : 611xxx/xxxxx (1)

Serial number : ... Year of construction : ...

Ex II 1G Ex ia IIC T6...T710°C Ga (2)

LCIE 12 ATEX 3053 X

$U_i \leq 30V$, $I_i \leq 100mA$, $P_i \leq 0,7W$, $C_i \leq 3300pF$, $L_i \leq 30\mu H$

(1)completed by the model

(2)temperature sensor and cable side

The equipment shall also bear the usual marking required by the manufacturing standards applying to such equipment.

16 DESCRIPTIVE DOCUMENTS

Certification file n°52740 rev.NR dated 2012/08/03.

This file includes 5 items (7 pages).

17 SPECIAL CONDITIONS FOR SAFE USE

The apparatus can be only connected to intrinsically safe certified equipment. These combinations shall be compatible as regard intrinsic safety rules (see electrical parameters clause 15 and drawing n°52744).

Ambient temperature of use : - 196°C to + 700°C.

Temperature classification : T6 at +80°C, T5 at +95°C, T4 at +130°C, T3 at +190°C, T2 at +290°C, T1 at +440°C, T710°C at +700°C.

18 ESSENTIAL HEALTH AND SAFETY REQUIREMENTS

Covered by standards listed at 9.

19 ROUTINE VERIFICATIONS AND TESTS

None.

20 CONDITIONS OF CERTIFICATION

Holders of EC type examination certificates are also required to comply with the production control requirements defined in article 8 of directive 94/9/EC.



IECEx Certificate of Conformity

INTERNATIONAL ELECTROTECHNICAL COMMISSION IEC Certification Scheme for Explosive Atmospheres

for rules and details of the IECEx Scheme visit www.iecex.com

Certificate No.:

IECEx LCIE 12.0002X

issue No.:1

Certificate history:

Issue No. 1 (2015-11-9)

Issue No. 0 (2012-8-30)

Status:

Current

Date of Issue:

2015-11-09

Page 1 of 4

Applicant:

IMI Sensors, a PCB Piezotronics Div.
3425 Walden Avenue
Depew, NY 14043
United States of America

Electrical Apparatus:
Optional accessory:

Vibration sensors
type EX611xxx/xxxxx

Type of Protection:

Ex ia

Marking:

Ex ia IIC T6...T710°C Ga
IECEx LCIE 12.0002 X

*Approved for issue on behalf of the IECEx
Certification Body:*

Julien GAUTHIER

Position:

Certification Officer

Signature:
(for printed version)

Date:

2015-11-09

1. This certificate and schedule may only be reproduced in full.
2. This certificate is not transferable and remains the property of the issuing body.
3. The Status and authenticity of this certificate may be verified by visiting the [Official IECEx Website](#).

Certificate issued by:

Laboratoire Central des Industries Electriques (LCIE)
33 Avenue du General Leclerc
FR-92260 Fontenay-aux-Roses
France

Documents relative to LCIE certification activities (Certificates, QARs, ExTRs) can be registered under the references "LCI" or "LCIE".



L C I E



IECEX Certificate of Conformity

Certificate No.: IECEX LCIE 12.0002X

Date of Issue: 2015-11-09

Issue No.: 1

Page 2 of 4

Manufacturer: **PCB Piezotronics**
3425 Walden Avenue
Depew, NY 14043
United States of America

Additional Manufacturing location
(s):

**PCB Piezotronics of
North Carolina Inc.**
10869 Hwy 903
Halifax, NC 27839
United States of America

This certificate is issued as verification that a sample(s), representative of production, was assessed and tested and found to comply with the IEC Standard list below and that the manufacturer's quality system, relating to the Ex products covered by this certificate, was assessed and found to comply with the IECEx Quality system requirements. This certificate is granted subject to the conditions as set out in IECEx Scheme Rules, IECEx 02 and Operational Documents as amended.

STANDARDS:

The electrical apparatus and any acceptable variations to it specified in the schedule of this certificate and the identified documents, was found to comply with the following standards:

IEC 60079-0 : 2007-10 Explosive atmospheres - Part 0: Equipment - General requirements
Edition: 5

IEC 60079-11 : 2011 Explosive atmospheres - Part 11: Equipment protection by intrinsic safety "i"
Edition: 6.0

*This Certificate **does not** indicate compliance with electrical safety and performance requirements other than those expressly included in the Standards listed above.*

TEST & ASSESSMENT REPORTS:

A sample(s) of the equipment listed has successfully met the examination and test requirements as recorded in

Test Report:

FR/LCIE/ExTR12.0003/00

FR/LCIE/ExTR15.0107/00

Quality Assessment Report:

NL/DEK/QAR14.0004/01



IECEx Certificate of Conformity

Certificate No.: IECEx LCIE 12.0002X

Date of Issue: 2015-11-09

Issue No.: 1

Page 3 of 4

Schedule

EQUIPMENT:

Equipment and systems covered by this certificate are as follows:

The apparatus is a vibration sensor, series high temperature sensor with integral cable and connector output. The vibration sensors provide a charge output when subjected to mechanical motion. The sensors have stainless steel housings.

CONDITIONS OF CERTIFICATION: YES as shown below:

The apparatus can be only connected to intrinsically safe certified equipment. These combinations shall be compatible as regard intrinsic safety rules (see drawing n°52744).

Ambient temperature of use : - 196°C to + 700°C.

Temperature classification : T6 at +80°C, T5 at +95 °C, T4 at +130°C, T3 at +190°C, T2 at +290°C, T1 at +440°C, T710°C at +700°C.



IECEX Certificate of Conformity

Certificate No.: IECEx LCIE 12.0002X

Date of Issue: 2015-11-09

Issue No.: 1

Page 4 of 4

DETAILS OF CERTIFICATE CHANGES (for issues 1 and above):

Issue 01 :

Modification of QAR

Addition of a manufacturing site

Modification of the applicant name



Annex 01 to Certificate IECEX LCIE 12.0002 X issue 01



Marking :

IMI Sensors

Address : ...

Type : EX611XXX/XXXXX ⁽¹⁾

Serial number : ...

Year of construction : ...

Ex ia IIC T6...T710°C Ga ⁽²⁾

IECEX LCIE 12.0002 X

U_i : 30V, I_i : 100mA, P_i : 0.7W, C_i : 3300pF, L_i : 30μH

⁽¹⁾ *completed by the model*

⁽²⁾ *temperature sensor and cable side*

Electrical parameters :

U_i : 30V, I_i : 100mA, P_i : 0.7W, C_i : 3300pF, L_i : 30μH



IECEx Certificate of Conformity

INTERNATIONAL ELECTROTECHNICAL COMMISSION IEC Certification Scheme for Explosive Atmospheres

for rules and details of the IECEx Scheme visit www.iecex.com

Certificate No.: IECEx LCIE 12.0002X issue No.:0 Certificate history:

Status: **Current**

Date of Issue: **2012-08-30** Page 1 of 3

Applicant: **IMI**
3425 Walden Avenue
Depew, NY 14043
United States of America

Electrical Apparatus: **Vibration sensors type EX611xxx/xxxxx**
Optional accessory:

Type of Protection: **ia**

Marking: **Ex ia IIC T6... T710°C Ga**

Approved for issue on behalf of the IECEx
Certification Body:

Michel BRENON

Position:

Certification Officer

Signature:
(for printed version)



August 28, 2012

Date:

1. This certificate and schedule may only be reproduced in full.
2. This certificate is not transferable and remains the property of the issuing body.
3. The Status and authenticity of this certificate may be verified by visiting the [Official IECEx Website](http://www.iecex.com).

Certificate issued by:

Laboratoire Central des Industries Electriques (LCIE)
33 Avenue du General Leclerc
FR-92260 Fontenay-aux-Roses
France

Documents relative to LCIE certification activities (Certificates,
QARs, ExTRs) can be registered under the references "LCI" or
"LCIE".





IECEX Certificate of Conformity

Certificate No.: IECEx LCIE 12.0002X

Date of Issue: 2012-08-30

Issue No.: 0

Page 2 of 3

Manufacturer: **IMI**
3425 Walden Avenue
Depew, NY 14043
United States of America

Manufacturing location(s):

This certificate is issued as verification that a sample(s), representative of production, was assessed and tested and found to comply with the IEC Standard list below and that the manufacturer's quality system, relating to the Ex products covered by this certificate, was assessed and found to comply with the IECEx Quality system requirements. This certificate is granted subject to the conditions as set out in IECEx Scheme Rules, IECEx 02 and Operational Documents as amended.

STANDARDS:

The electrical apparatus and any acceptable variations to it specified in the schedule of this certificate and the identified documents, was found to comply with the following standards:

IEC 60079-0 : 2007-10 Explosive atmospheres - Part 0: Equipment - General requirements
Edition: 5

IEC 60079-11 : 2011-06 Explosive atmospheres - Part 11: Equipment protection by intrinsic safety "i"
Edition: 6.0

*This Certificate **does not** indicate compliance with electrical safety and performance requirements other than those expressly included in the Standards listed above.*

TEST & ASSESSMENT REPORTS:

A sample(s) of the equipment listed has successfully met the examination and test requirements as recorded in

Test Report:

[FR/LCIE/ExTR12.0003/00](#)

Quality Assessment Report:

[CA/CSA/QAR09.0018/00](#)

[CA/CSA/QAR09.0018/01](#)



IECEx Certificate of Conformity

Certificate No.: IECEx LCIE 12.0002X

Date of Issue: 2012-08-30

Issue No.: 0

Page 3 of 3

Schedule

EQUIPMENT:

Equipment and systems covered by this certificate are as follows:

The apparatus is a vibration sensor, series high temperature sensor with integral cable and connector output. The vibration sensors provide a charge output when subjected to mechanical motion. The sensors have stainless steel housings.

Marking :

IMI Address : ...

Type : EX611XXX/XXXXX (1)

Serial number : ... Year of construction : ...

Ex ia IIC T6...T710°C Ga (2)

IECEx LCIE 12.0002 X

$U_i \leq 30V$, $I_i \leq 100mA$, $P_i \leq 0,7W$, $C_i \leq 3300pF$, $L_i \leq 30\mu H$

(1) completed by the model

(2) temperature sensor and cable side

Electrical parameters :

$U_i \leq 30V$, $I_i \leq 100mA$, $P_i \leq 0,7W$, $C_i \leq 3300pF$, $L_i \leq 30\mu H$

CONDITIONS OF CERTIFICATION: YES as shown below:

The apparatus can be only connected to intrinsically safe certified equipment. These combinations shall be compatible as regard intrinsic safety rules (see drawing n°52744).

Ambient temperature of use : - 196°C to + 700°C.

Temperature classification : T6 at +80°C, T5 at +95°C, T4 at +130°C, T3 at +190°C, T2 at +290°C, T1 at +440°C, T710°C at +700°C.

EU Declaration of Conformity PS122
In Accordance with ISO/IEC 17050

Manufacturer: PCB Piezotronics, Inc. 3425 Walden Avenue Depew, New York 14043 USA	Authorized European Representative: PCB Piezotronics Europe GmbH Porschestrasse 20-30 41836 Hückelhoven, Germany
--	---

Certifies that type of equipment: High Temperature Accelerometer(s)

Whose Product Models Include: EX611XXX Series

This declaration is applicable to all High Temperature Accelerometer(s) of the above series which have the CE & ATEX mark on their data sheets and where those data sheets refer to this declaration of conformity. The data sheets for all model numbers referenced above, which include the CE & ATEX mark on such data sheets and refer to this Declaration of Conformity are hereby incorporated by reference into this Declaration.

Conform to the following EU Directive(s) when installed per product documentation:	2014/34/EU 2011/65/EU w/2015/863/EU	ATEX Directive RoHS Directive
---	--	----------------------------------

Standards to which Conformity is Declared:

Harmonized Standards	EN 60079-0 :2012+ A11:2013 EN 60079-11 2012 EN 63000:2018	General Explosive Atmosphere Intrinsic safe, i Technical documentation for the assessment of electrical and electronic products with respect to the restriction of hazardous substances
EC Type Examination	ATEX Certification	LCIE 12 ATEX 3053 X Ex ia II C T6 ...710°C Ga, II 1G
Other International Certifications	IECEX Certification	ICECX LCIE 12.0002X Ex ia II C T6 ...710°C Ga
Notified Body Name		Laboratoire Central des Industries Electriques (0081)
Notified Body's Address		FONTENAY-AUX-ROSES (Head Office) 33, avenue du Général Leclerc FR- 92260 Fontenay-aux-Roses Tel. : + 33 1 40 95 60 60 Fax : + 33 1 40 95 86 56

I, the undersigned, hereby declare that the equipment specified above conforms to the above Directive(s) Standard(s)

Place: Depew, NY **Date:** 7/09/2021

Signature:

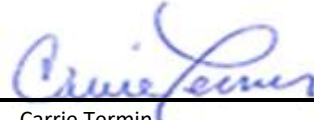

Name:

Carrie Termin

Title:

Regulatory Affairs and Product Certification Specialist