



Model EX638A06

Intrinsically-safe, cryogenic, industrial, quartz shear ICP accel, 25mV/g, 4 to 1.5kHz, side exit, 2-pin conn.

Installation and Operating Manual

**For assistance with the operation of this product,
contact the PCB Piezotronics, Inc.**

Toll-free: 800-959-4464

24-hour SensorLine: 716-684-0001

Fax: 716-684-3823

E-mail: imi@pcb.com

Web: www.imi-sensors.com



Repair and Maintenance

PCB guarantees Total Customer Satisfaction through its “Lifetime Warranty Plus” on all Platinum Stock Products sold by PCB and through its limited warranties on all other PCB Stock, Standard and Special products. Due to the sophisticated nature of our sensors and associated instrumentation, **field servicing and repair is not recommended and, if attempted, will void the factory warranty.**

Beyond routine calibration and battery replacements where applicable, our products require no user maintenance. Clean electrical connectors, housings, and mounting surfaces with solutions and techniques that will not harm the material of construction. Observe caution when using liquids near devices that are not hermetically sealed. Such devices should only be wiped with a dampened cloth—never saturated or submerged.

In the event that equipment becomes damaged or ceases to operate, our Application Engineers are here to support your troubleshooting efforts 24 hours a day, 7 days a week. Call or email with model and serial number as well as a brief description of the problem.

Calibration

Routine calibration of sensors and associated instrumentation is necessary to maintain measurement accuracy. We recommend calibrating on an annual basis, after exposure to any extreme environmental influence, or prior to any critical test.

PCB Piezotronics is an ISO-9001 certified company whose calibration services are accredited by A2LA to ISO/IEC 17025, with full traceability to SI through N.I.S.T. In addition to our standard calibration services, we also offer specialized tests, including: sensitivity at elevated or cryogenic temperatures, phase response, extended high or low frequency response, extended range, leak testing, hydrostatic pressure testing, and others. For more information, contact your local PCB Piezotronics distributor, sales representative, or factory customer service representative.

Returning Equipment

If factory repair is required, our representatives will provide you with a Return Material Authorization (RMA) number, which we use to reference any information you have already provided and expedite the repair process. This number should be clearly marked on the outside of all returned package(s) and on any packing list(s) accompanying the shipment.

Contact Information

PCB Piezotronics, Inc.
3425 Walden Ave.
Depew, NY14043 USA
Toll-free: (800) 828-8840
24-hour SensorLine: (716) 684-0001
General inquiries: info@pcb.com
Repair inquiries: rma@pcb.com

For a complete list of distributors, global offices and sales representatives, visit our website, www.pcb.com.

Safety Considerations

This product is intended for use by qualified personnel who recognize shock hazards and are familiar with the precautions required to avoid injury. While our equipment is designed with user safety in mind, the protection provided by the equipment may be impaired if equipment is used in a manner not specified by this manual.

Discontinue use and contact our 24-Hour Sensorline if:

- Assistance is needed to safely operate equipment
- Damage is visible or suspected
- Equipment fails or malfunctions

For complete equipment ratings, refer to the enclosed specification sheet for your product.

Definition of Terms and Symbols

The following symbols may be used in this manual:



DANGER

Indicates an immediate hazardous situation, which, if not avoided, may result in death or serious injury.

**CAUTION**

Refers to hazards that could damage the instrument.

**NOTE**

Indicates tips, recommendations and important information. The notes simplify processes and contain additional information on particular operating steps.

The following symbols may be found on the equipment described in this manual:



This symbol on the unit indicates that high voltage may be present. Use standard safety precautions to avoid personal contact with this voltage.



This symbol on the unit indicates that the user should refer to the operating instructions located in the manual.



This symbol indicates safety, earth ground.



PCB工业监视和测量设备 - 中国RoHS2公布表

PCB Industrial Monitoring and Measuring Equipment - China RoHS 2 Disclosure Table

部件名称	有害物质					
	铅 (Pb)	汞 (Hg)	镉 (Cd)	六价铬 (Cr(VI))	多溴联苯 (PBB)	多溴二苯醚 (PBDE)
住房	0	0	0	0	0	0
PCB板	X	0	0	0	0	0
电气连接器	0	0	0	0	0	0
压电晶体	X	0	0	0	0	0
环氧	0	0	0	0	0	0
铁氟龙	0	0	0	0	0	0
电子	0	0	0	0	0	0
厚膜基板	0	0	X	0	0	0
电线	0	0	0	0	0	0
电缆	X	0	0	0	0	0
塑料	0	0	0	0	0	0
焊接	X	0	0	0	0	0
铜合金/黄铜	X	0	0	0	0	0
本表格依据 SJ/T 11364 的规定编制。						
0：表示该有害物质在该部件所有均质材料中的含量均在 GB/T 26572 规定的限量要求以下。						
X：表示该有害物质至少在该部件的某一均质材料中的含量超出 GB/T 26572 规定的限量要求。						
铅是欧洲RoHS指令2011/65/ EU附件三和附件四目前由于允许的豁免。						

CHINA RoHS COMPLIANCE

Component Name	Hazardous Substances					
	Lead (Pb)	Mercury (Hg)	Cadmium (Cd)	Chromium VI Compounds (Cr(VI))	Polybrominated Biphenyls (PBB)	Polybrominated Diphenyl Ethers (PBDE)
Housing	O	O	O	O	O	O
PCB Board	X	O	O	O	O	O
Electrical Connectors	O	O	O	O	O	O
Piezoelectric Crystals	X	O	O	O	O	O
Epoxy	O	O	O	O	O	O
Teflon	O	O	O	O	O	O
Electronics	O	O	O	O	O	O
Thick Film Substrate	O	O	X	O	O	O
Wires	O	O	O	O	O	O
Cables	X	O	O	O	O	O
Plastic	O	O	O	O	O	O
Solder	X	O	O	O	O	O
Copper Alloy/Brass	X	O	O	O	O	O

This table is prepared in accordance with the provisions of SJ/T 11364.

O: Indicates that said hazardous substance contained in all of the homogeneous materials for this part is below the limit requirement of GB/T 26572.

X: Indicates that said hazardous substance contained in at least one of the homogeneous materials for this part is above the limit requirement of GB/T 26572.

Lead is present due to allowed exemption in Annex III or Annex IV of the European RoHS Directive 2011/65/EU.



INDUSTRIAL MONITORING INSTRUMENTATION DIVISION

Piezoelectric ICP® Accelerometers Operating Guide

Operating Guide with Enclosed Warranty Information

3424 Walden Avenue, Depew, New York 14043-2495

Phone (716) 684-0003

Fax (716) 684-3823

Toll Free Line 1-800-959-4IMI

***MANUAL NUMBER: 18405
MANUAL REVISION: A***

ECN NUMBER: 49766

General
OPERATING GUIDE

for use with

PIEZOELECTRIC ICP® ACCELEROMETERS

SPECIFICATION SHEET, INSTALLATION DRAWING AND CALIBRATION INFORMATION ENCLOSED

IMI ASSUMES NO RESPONSIBILITY FOR DAMAGE CAUSED TO THIS PRODUCT AS A RESULT OF PROCEDURES THAT ARE INCONSISTENT WITH THIS OPERATING GUIDE

1.0 INTRODUCTION

Congratulations on the purchase of a quality ICP® industrial sensor. In order to ensure the highest level of performance for this product, it is imperative that you properly familiarize yourself with the correct mounting and installation techniques before attempting to operate this device. If, after reading this manual, you have any additional questions concerning this sensor or its application, feel free to call an Application Engineer at **716-684-0003** or **800-959-4464**.

Proper sensor selection requires special attention to three main areas: sensor design, dynamic expectations, and application environment.

Sensor design encompasses the actual sensing element, the physical material, and component selection for the sensor. Preferred industrial accelerometers employ a shear sensing element with either a quartz or ceramic crystal.

Quartz sensing elements are typically used when long-term stability and minimum output shifts due to temperature changes are desired. Ceramic sensing elements provide excellent resolution and durability in noisy environments, and can be designed to supply low-frequency and high-frequency measurements. Shear-design sensors are preferred because of their inherent insensitivity to adverse environmental influences, such as case or base strain and thermal transients. Internal case isolation and shielding is important in avoiding erroneous signals resulting from ground loops and pick-up of electromagnetic and radio frequency interference. Other critical material selection criteria include non-magnetic stainless steel housing, hermetic sealing, and industrial military connectors. See Figure 1.

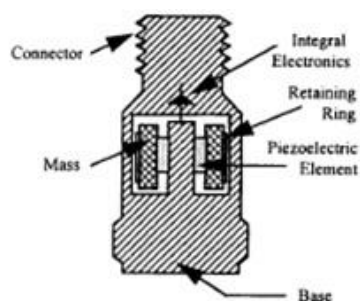

Figure 1. Typical Industrial Shear Mode Accelerometer

Dynamic expectations are application-specific and refer to the frequency range of measurement and the anticipated amplitudes of vibration. After careful review of the machinery to be monitored, minimum and maximum measurement frequency ranges may be established. The minimum measurement frequency is normally related to any sub-harmonics of running speed or any lower frequencies where vibration data is to be collected. The maximum measurement frequency of interest is determined by the maximum number of harmonics of an event like running speed, bearing frequencies, or gear mesh. This measurement frequency range should be well within the specified frequency range of the sensor.

Amplitude range refers to the anticipated levels of vibration to be measured. These values are related to the alarm levels set for the machine. By carefully evaluating the idiosyncrasies of the machinery, the predictive maintenance engineer can estimate the minimum expected vibration levels and ensure that the electrical noise floor of the accelerometer is less than those levels.

The environment of the application is a critical consideration during program implementation. The sensor chosen must be capable of surviving the wide range of conditions to which it is subjected; therefore, take time to evaluate potential conditions, such as high temperatures and chemical contaminants. The specified temperature range of the sensor must conform to the fluctuations of the environmental temperature. If harsh industrial chemicals are present, the sensor requires hermetic sealing and construction that resists corrosion. Finally, specific location of the sensor within the environment must be sensible, as both cable and sensor may be damaged by imprudent installation in heavily traveled, physically punishing areas.

2.0 ICP® ACCELEROMETERS

Enclosed in the back of this guide is a Specification Sheet, which lists the complete performance characteristics of the particular sensor.

All ICP® sensors require a constant current power source for proper operation. A typical sensing system includes an ICP® sensor, ordinary two conductor cable and a basic constant current power supply (as shown in Figure 2).

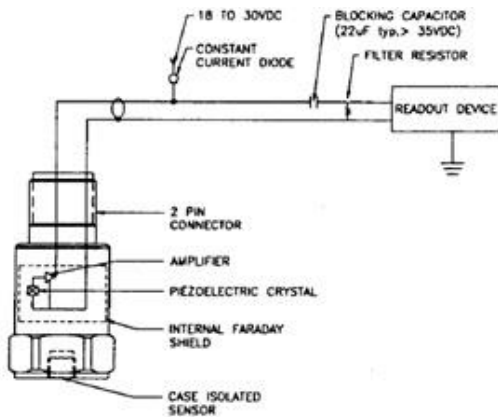

Figure 2. Typical Sensor System

The signal conditioner consists of a well-regulated 18 to 30 VDC source (battery or line-powered), a current-regulating diode (or equivalent constant current circuit), and a capacitor for decoupling (removing the bias voltage) the signal.

The current-regulating device is used in place of a resistor for several reasons. The very high dynamic resistance of the diode yields a source follower gain which is extremely close to unity and independent of

input voltage. Also, the diode can be changed to supply higher currents for driving long cable lengths. Constant current diodes, as shown in Figure 3, should be used in ICP® signal conditioners. **(The correct orientation of the diode within the circuit is critical for proper operation.)** Except for special models, standard ICP® sensors require a minimum of 2 mA for proper operation.

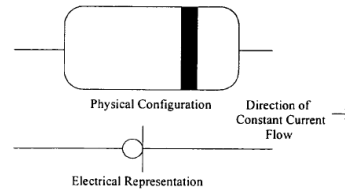

Figure 3. Constant Current Diode

The typical limits for this type of diode are to a 4 mA maximum rating; however, several diodes can be placed in parallel for higher current levels. All line-powered signal conditioners should use higher capacity (up to 20 mA) constant current circuits in place of the diodes, particularly when driving long signal cables (see Section 5).

Decoupling of the data signal occurs at the output stage of the signal conditioner. A 10 to 30 µF capacitor coupled with a resistor shifts the signal level to essentially eliminate the sensor bias voltage. The result is a drift-free AC mode of operation.

3.0 OPTIONAL FEATURES

In addition to standard features, a variety of options are also available. When listed before the model number, the following prefix letters indicate that the sensor is manufactured or supplied with optional features:

- CS - Canadian Standards Association Approved Sensor
- D - Dummy, non-working sensor for display purposes
- EX - Cenelec Approved Sensor
- FM - Factory Mutual Approval Sensor
- HT - High temperature accelerometer (325 °F)
- LB - Low Bias electronics
- LC - Limited Calibration (one point calibration)
- LP - Low Pass filter
- M - Metric mounting hardware and cable length
- U - Usable demonstration sensor (does not meet one or more minor specifications)
- VO - Velocity Output Sensors

MS – Mine Safety Approved Sensors
 TO – Temperature Output Sensor

Note: *Not all sensors are available with the optional prefixes. Contact the factory to discuss special features that may be needed.*

4.0 INSTALLATION OVERVIEW

When choosing a mounting method, consider closely both the advantages and disadvantages of each technique. Characteristics like location, ruggedness, amplitude range, accessibility, temperature, and portability are extremely critical. However, the most important and often overlooked consideration is the effect the mounting technique has on the high-frequency operating range of the accelerometer.

Shown in Figure 4 are six possible mounting techniques and their effects on the performance of a typical piezoelectric accelerometer. (**Note:** *Not all of the mounting methods may apply to your particular sensor.*) The mounting configurations and corresponding graph demonstrate how the high-frequency response of the accelerometer may be compromised as mass is added to the system and/or the mounting stiffness is reduced.

Note: *The low-frequency response is unaffected by the mounting technique. This roll-off behavior is typically fixed by the sensor's built-in electronics. However, when operating AC-coupled signal conditioners with readout devices having an input impedance of less than one megaohm, the low frequency range may be affected.*

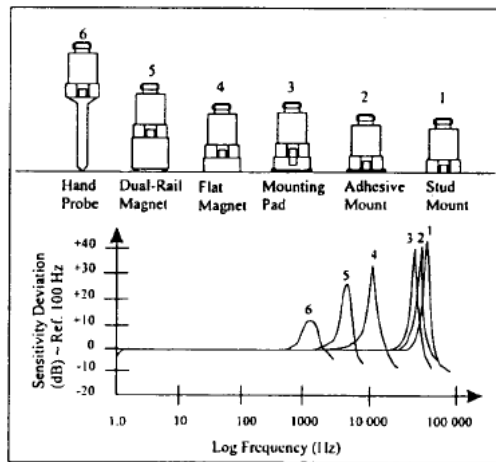
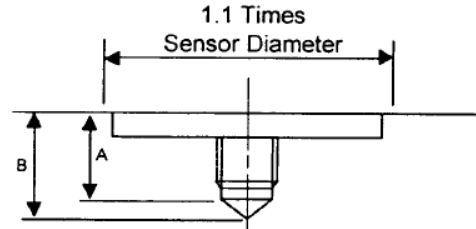

Figure 4. Assorted Mounting Configurations and Their Effects on High Frequency

4.1 STANDARD STUD MOUNT

This mounting technique requires smooth, flat contact surfaces for proper operation and is recommended for permanent and/or secure installations. Stud mounting is also recommended when testing at high frequencies.

Note: *Do NOT attempt mounting on curved, rough, or uneven surfaces, as the potential for misalignment and limited contact surface may significantly reduce the sensor's upper operating frequency range.*



	1/4-28 Stud	1/4-28 Captive Screw
A (in.)	.250	.250
B (in.)	.350	.350
Torque (ft-lb)	2 to 5	2 to 5

Figure 5. Mounting Surface Preparation

STEP 1: First, prepare a smooth, flat mounting surface and then drill and tap a mounting hole in the center of this area as shown in Figure 5.

A precision-machined mounting surface with a minimum finish of 63 μin (0.0016 mm) is recommended. (If it is not possible to properly prepare the machine surface, consider using an adhesive mounting pad as a possible alternative.) Inspect the area, checking that there are no burrs or other foreign particles interfering with the contact surface.

STEP 2: Wipe clean the mounting surface and spread on a light film of grease, oil, or similar coupling fluid prior to installation. See Figure 6.

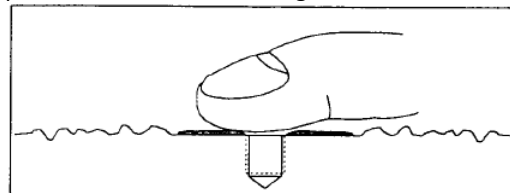

Figure 6. Mounting Surface Lubrication

Adding a coupling fluid improves vibration transmissibility by filling small voids in the mounting surface and increasing the mounting stiffness. For

semi-permanent mounting, substitute epoxy or another type of adhesive.

STEP 3: Hand-tighten the sensor/mounting stud to the machine, then secure the sensor with a torque wrench to the mounting surface by applying the recommended mounting torque. (See enclosed specification data sheet for proper mounting torque.)

It is important to use a torque wrench during this step. Under-torqueing the sensor may not adequately couple the device; over-torqueing may result in stud failure and possibly permanent damage.

4.2 ADHESIVE MOUNT

Adhesive mounting is often used for temporary installation or when the machine surface cannot be adequately prepared for stud mounting. Adhesives like hot glue or wax work well for temporary mounts; two-part epoxies and quick-bonding gels provide a more permanent mount.

Note: *Adhesively-mounted sensors often exhibit a reduction in high-frequency range. Generally, smooth surfaces and stiff adhesives provide the best frequency response. Contact the factory for recommended epoxies.*

METHOD 1 – Adhesive mounting base

This method involves attaching a base to the machine surface, then securing the sensor to the base. This allows for easy removal of the accelerometer.

STEP 1: Prepare a smooth, flat mounting surface. A minimum surface finish of 63 μin (0.0016 mm) generally works best.

STEP 2: Stud-mount the sensor to the appropriate adhesive mounting base according to the guidelines set forth in **STEPS 2** and **3** of the Stud Mount Procedure.

STEP 3: Place a small portion of adhesive on the underside of the mounting base. Firmly press down on the assembly to displace any extra adhesive remaining under the base. See Figure 7.

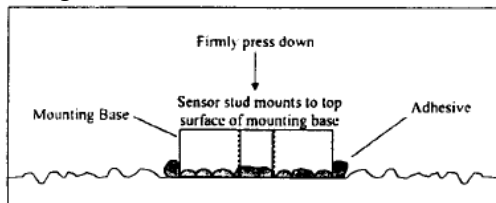

Figure 7. Mounting Base: Adhesive Installation

METHOD 2 – Direct Adhesive Mount

For restrictions of space or for convenience, most sensors (with the exception of integral stud models) can be adhesive-mounted directly to the machine surface.

STEP 1: Prepare a smooth, flat mounting surface. A minimum surface finish of 63 μin (0.0016 mm) generally works best.

STEP 2: Place a small portion of adhesive on the underside of the sensor. Firmly press down on the top of the assembly to displace any adhesive. Be aware that excessive amounts of adhesive can make sensor removal difficult. See Figure 8.

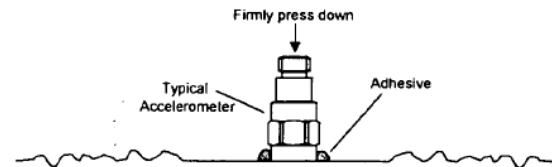

Figure 8. Direct Adhesive Mounting

4.3 MAGNETIC MOUNT

Magnetic mounting provides a convenient means for making portable measurements and is commonly used for machinery monitoring and other portable or trending applications.

Note: *The correct magnet choice and an adequately prepared mounting surface are critical for obtaining reliable measurements, especially at high frequencies. Poor installations can cause as much as a 50% drop in the sensor frequency range.*

Not every magnet is suitable for all applications. For example, rare earth magnets are commonly used because of their high strength. Flat magnets work well on smooth, flat surfaces, while dual-rail magnets are required for curved surfaces. In the case of non-magnetic or rough surfaces, it is recommended that the user first weld, epoxy, or otherwise adhere a steel mounting pad to the test surface. This provides a smooth and repeatable location for mounting.

STEP 1: After choosing the correct magnet type, inspect the unit, verifying that the mounting surfaces are flat and smooth. See Figure 9.

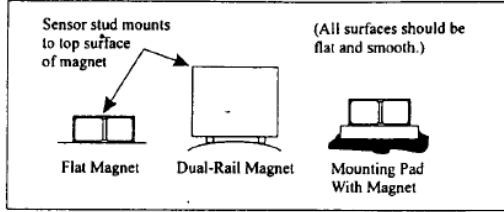

Figure 9. Magnet Types

STEP 2: Stud-mount the accelerometer to the appropriate magnet according to the guidelines set forth in **STEPS 2** and **3** of the Stud Mount Procedure.

STEP 3: Prepare a smooth, flat mounting surface. A minimum surface finish of 63 μin (0.0016 mm) generally works best. After cleaning the surface and checking for burrs, wipe on a light film of silicone grease, machine oil, or similar-type coupling fluid.

STEP 4: Mount the magnet/sensor assembly to the prepared test surface by gently “rocking” or “sliding” it into place. See Figure 10.

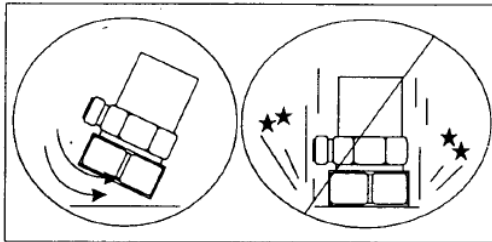

Figure 10. Magnet Mounting

Note: *Magnetically mounting accelerometers carelessly has the potential to generate very high (and very damaging) g levels. To prevent damage, install the assembly gently. If unsure, please contact the factory for assistance.*

4.4 HANDHELD OR PROBE TIP MOUNT

This method is NOT recommended for most applications. It is generally used where access to machinery may be a safety concern. Both the accuracy and repeatability at low (<5 Hz) and high frequency (>1 kHz) ranges are questionable.

5.0 CABLING

The selection of connectors and cables has a direct impact on the ruggedness and reliability of the sensor installation. A consideration when dealing with cables is the way in which the cable conductors are terminated.

ICP® accelerometers are internally amplified, two-wire accelerometers. Connections to the sensor require two leads: one for the power and signal, and the other for the common and signal return. Often, coaxial cables are used since only two conductors are needed. Coaxial cables are less expensive. With coaxial cables, however, erroneous signals can be introduced into sensor systems through ground loops, electromagnetic interference, or radio frequency interference (EMI or RFI). To avoid ground loops, there should only be one ground in the system.

It is recommended for permanent installations that the sensor be case-isolated and internally shielded with a dual-case design and use a two-conductor shielded cable to insure clean vibration signal transmission. Two-conductor shielded cables allow the signal and the signal return (common) to be fully shielded from the sensor to the readout equipment. To insure that ground loop signals are not induced, the shield should only be terminated at one end. Typically, the shield of a two-conductor shielded cable is left open or not connected at the sensor end and is tied to earth ground at the instrumentation end.

Operation over long cables may affect the frequency response of ICP® accelerometers, and introduce low frequency noise and high frequency distortion when an insufficient current is available to drive cable capacitance.

Unlike charge mode systems, where the system noise is a function of cable length, ICP® sensors provide a high voltage, low impedance output well-suited for driving long cables through harsh environments. While there is virtually no increase in noise with ICP® sensors, the capacitive loading of the longer cable may be distort or filter higher frequency signals depending on the supply current and the output impedance of the sensor.

Generally, this signal distortion is not a problem with lower frequency testing within a range up to 1,000 Hz. However, when monitoring higher frequency vibrations traveling over cables longer than 500ft, the possibility of signal distortion exists.

The maximum frequency that can be transmitted over a given cable length is a function of both the cable capacitance and the ratio of the peak signal voltage to the current available from the signal conditioner according to:



$$f_{\max} = \frac{10^9}{2\pi CV} \quad (\text{Equation 1})$$

[L_c-1]

Where, f_{\max} = maximum frequency (hertz)
C = cable capacitance (picofarads)
V = maximum peak output from sensor (volts)
 L_c = constant current from signal conditioner (mA)
 10^9 = scaling factor to equate units

Note that in this equation, 1 mA is subtracted from the total current supplied to sensor (L_c). This is done to compensate for powering the internal electronics. Also, note that these are typical values only.

When driving long cables, Equation 1 shows that, as the length of the cable, peak voltage output or maximum frequency of interest increases, a greater constant current will be required to drive the signal.

The nomograph on page 12 of this manual provides a simple, graphical method for obtaining the expected maximum frequency capability of an ICP® measurement system. The maximum peak signal voltage amplitude, cable capacitance and supplied constant current must be known or presumed.

For example, when running at 100 ft (30.5 m) cable with a capacitance of 30 pF/ft, the total capacitance is 3,000pF. This value can be found along the diagonal cable capacitance lines. Assuming the sensor operates at a maximum output range of 5 volts and the constant current available from the power supply is 2 mA, the ratio on the vertical axis can be calculated to equal 5. The intersection of the total cable capacitance and this ratio result in a maximum frequency of approximately 10.2 kHz.

The nomograph does not indicate whether the frequency amplitude response at a point is flat, rising or falling. For precautionary reasons, it is good general practice to increase the constant current (if possible) to the sensor (within its maximum limit) so that the frequency determined from the nomograph is approximately 1.5 to 2 times greater than the maximum frequency of interest.

Note: Higher current levels will deplete battery-powered signal conditioners at a faster rate. Also, any current not used by the cable goes directly to power the internal electronics and will create heat. This may cause the sensor to

exceed its maximum temperature specification. For this reason, do not supply excessive current over short cable runs or when testing at elevated temperatures.

5.1 CABLE CONNECTOR PROCEDURE

Care and attention to installation is essential, as the reliability and accuracy of your system is no better than that of the output cable.

STEP 1: Ascertain that you have ordered the correct cable type.

As with sensors, no cable can satisfy all applications. Special low-noise cabling should be used with high impedance, charge-output devices. ICP® sensors usually operate with any ordinary tow-wire cable. Industrial applications often require twisted/shielded cables to reduce the effects of EMI and RFI. PTFE-jacketed cabling may be necessary to withstand corrosive environments.

STEP 2: Connect the cable to the accelerometer. A small amount of thread-locking compound placed on the connector prior to attachment helps secure the cable during testing. In harsh environments, the connection can be sealed with silicone rubber, O-rings, and flexible heat-shrink tubing.

STEP 3: Plug the connector of the cable into the mating sensor connector. Then, holding the sensor stationary, secure the connector in place by tightening down the attached threaded cable sleeve.

STEP 4: Route the cable to the signal conditioner, making certain to stress-relieve the sensor/cable connection and minimize motion by clamping the cable at regular intervals.

Common sense should be used to avoid physical damage and minimize electrical noise. For instance, avoid routing cables near high-voltage wires. Do not route cables along floors or walkways where they be stepped on or become contaminated. Shielded cables should have the shield grounded at one end only, normally at the instrumentation end.

STEP 5: Finally, connect the remaining cable end to the signal conditioner or readout device. To dissipate charge that may have accumulated in the cable short the signal to ground prior to attachment.

6.0 POWERING

All ICP® sensors require constant current excitation for proper operation. For this reason only use approved constant-current sources. A typical system schematic is shown in Figure 11.

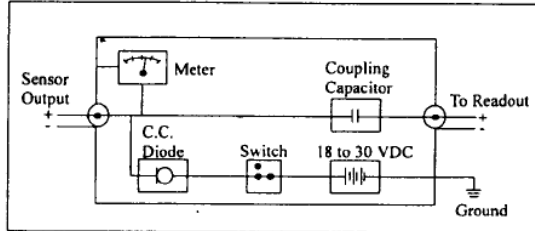

Figure 11. Typical System Schematic

The power supply consists of a regulated 18 to 30 VDC source. In general, battery-powered devices offer versatility for portable, low-noise measurements, whereas line-powered units provide the capability for continuous monitoring. This power is regulated by a current-limiting circuit, which provides the constant-current excitation required for proper operation of sensors with integral electronics.

Note: Under no circumstances should a voltage be supplied to an ICP® accelerometer without a current-regulating diode or equivalent electrical circuit.

A capacitor at the output stage of the device removes the sensor output bias voltage from the measurement signal. This provides a zero-based, AC-coupled output compatible with most standard readout devices.

Today, many FFT analyzers, data acquisition modules, and data collectors have constant-current excitation for direct use with ICP® sensors. However, before using this feature, check that the supply voltage and constant current are adequate for use with your sensor. Please contact the respective signal conditioner manufacturer or check the product manual for more information.

7.0 OPERATING

After completing the system setup, switch on the conditioner, the meter (or LED) and allow the sensor to power up. If a faulty condition is monitored, first check all system connections, then check the functionality of the cable and signal conditioner. If

the system still does not operate properly, consult an IMI Application Engineer.

Note: Always operate the accelerometer within the limitations listed on the Specification Sheet of your sensor. Operating the device outside of its parameters can cause temporary or permanent damage to the sensor.

8.0 ACCELEROMETER CALIBRATION

Note: It is good measurement practice to verify the performance of each accelerometer before and after each measurement.

Accelerometers are precision measuring instruments. They are highly engineered to provide accurate electrical signals representative of the vibration being monitored. Each sensor is calibrated by comparison to a known acceleration level. Some calibrations include frequency response curves, resonant frequency measurements, transvers sensitivity, and many other valuable tests. Applications requiring a high degree of accuracy or those in plants requiring certification and traceability require full calibration test results.

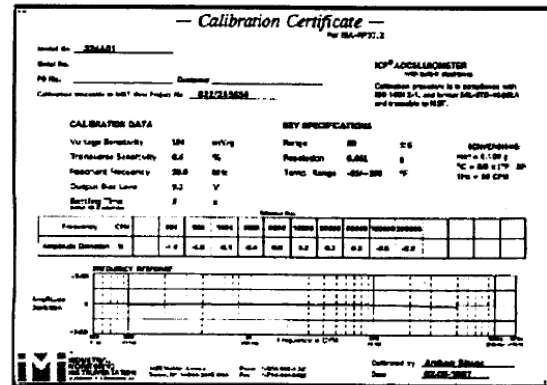

Figure 12. Typical Calibration Certificate

Some applications have much less stringent requirements for calibration certification. Simple sensitivity measurements at a single frequency may be sufficient; operational verification and certificates of conformance to published specifications may satisfy many plants' calibration needs. Reducing the final calibration requirements reduces the cost of manufacturing the sensor and should lower the price for predictive maintenance users.

Periodic recalibration may be required by plants with strict certification and traceability requirements. It is always recommended that the user has the sensor recalibrated periodically, particularly if the sensor has experienced a very high shock level or extreme temperatures for extended periods of time. Some plants develop in-house calibration capabilities for periodically verifying the performance of accelerometers. Products are available that provide a set 1 g-acceleration level at a fixed frequency for quick sensor checking.

For these reasons, it is recommended that a recalibration cycle be established for each accelerometer. This schedule is unique and is based on a variety of factors, such as extent of use, environmental conditions, accuracy requirements, trend information obtained from previous calibration records, contractual regulations, frequency of “cross-checking” against other equipment, manufacturer recommendation, and any risk associated with incorrect readings. International standards, such as ISO 10012-1, provide insight and suggested methods for determining recalibration intervals for most measuring equipment. With the above information in mind and under “normal” circumstances, a conservative suggestion of 12 to 24 month recalibration cycle for most piezoelectric accelerometers is advised.

8.1 SENSOR CALIBRATION

Accelerometer recalibration services are typically performed by IMI’s internal metrology laboratory. (Other international and private laboratories are also available.) The IMI laboratory is certified to ISO 9001, complies with ISO 10012-1 (and former MIL-STD-45662A), and uses equipment directly traceable to NIST. This assures an accurate calibration of relevant specifications.

The following includes a broad overview of the Back-to-Back Calibration technique normally used when calibrating accelerometers. This technique provides a quick and easy method for determining the sensitivity of a test accelerometer over a wide frequency range.

8.2 BACK-TO-BACK CALIBRATION THEORY

Back-to-back calibration is perhaps the most common method for determining the sensitivity of

piezoelectric accelerometers. This method relies on a simple comparison to a previously calibrated accelerometer, typically referred to as a reference standard, as shown in Figure 12.

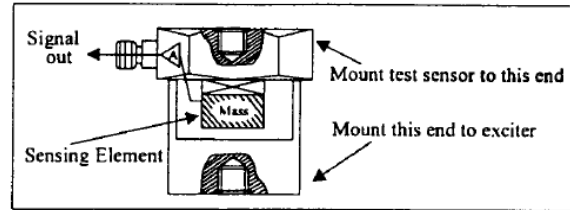

Figure 12. Reference Standard Accelerometer

These high-accuracy devices, which are directly traceable to a recognized standards laboratory, are designed for stability, as well as configured to accept a test accelerometer. By mounting a test accelerometer to the reference standard and then connecting this combination to a suitable vibration source, it is possible to vibrate both devices and compare the data as shown in Figure 13. (Test setups may be automated and vary, depending on the type and number for accelerometers being calibrated.)

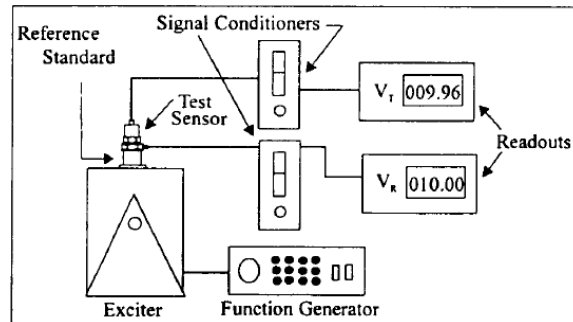

Figure 13. Typical Back-to-Back Calibration System

Because the acceleration is the same on both sensors, the ratio of their outputs (V_T/V_R) must also be the ratio of their sensitivities. With the sensitivity of the reference standard (S_R) known, the exact sensitivity of the test sensor (S_T) is easily calculated by using the following equation:

$$S_T = S_R \left(\frac{V_T}{V_R} \right)$$

By varying the frequency of the vibration, the sensor may be calibrated over its entire operating frequency range. The typical response of an unfiltered accelerometer is shown in Figure 14.

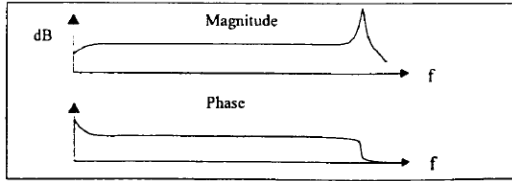

Figure 14. Typical Test Accelerometer Response

9.0 TROUBLESHOOTING

Piezoelectric sensors are dynamic measuring equipment. They use piezoelectric sensing elements to convert or transduce the mechanical phenomena to an electrical signal. The mechanical parameter may be force, pressure or vibration. The raw electrical signal from a piezoelectric charge element is a high impedance signal. This charge signal is normally converted to a low impedance voltage signal by either an external charge amplifier or an external voltage amplifier. The cables between the charge sensor and the amplifier must be high quality, low noise cable and must be kept as short as possible. Figure 15 shows a typical high impedance system.

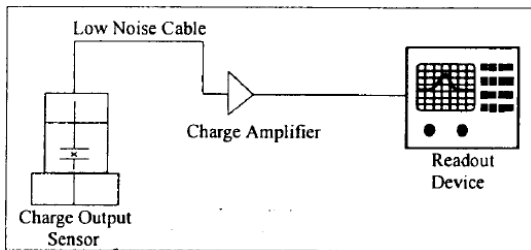

Figure 15. High Impedance System Connection

Internally amplified sensors employ miniature amplifiers to convert the high impedance charge signal into a low impedance voltage signal. These amplifiers are internal to the sensor, and therefore, do not require low noise cables or external amplifiers. These amplifiers have set gain so that output sensitivities are standardized.

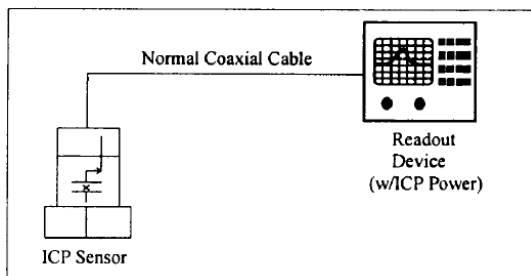

Figure 16. Sensor with Integral Electronics System Connector

ICP® sensors are two-wire sensors. They are powered with a constant current DC source. The power supply is typically 18 to 30 volts DC current limited via a constant current between 2 and 20 mA. Typical battery operated supplies offer 2mA of constant current to extend battery life while continuous monitoring systems offer more current in order to drive longer cables. Figure 16 shows a typical system for a sensor with integral electronics.

The signal output of a sensor with integral electronics is a low impedance voltage signal proportional to the dynamic measurement such as force, pressure, or vibration. This voltage signal is carried on a DC bias voltage. The AC dynamic signal is superimposed on the DC bias voltage and is allowed to swing between the supply voltage and ground as shown in Figure 17. Unlike an operational amplifier that requires a plus and minus supply and allows the signal to “ride” on ground and “swing” between the plus and minus “rails,” the sensor with integral electronics requires the output signal to be DC biased.

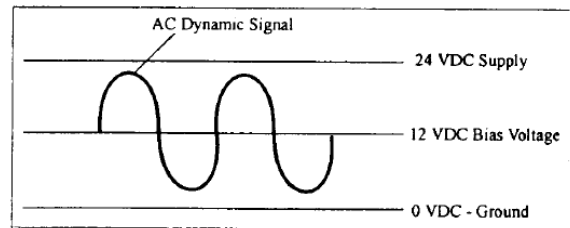

Figure 17. Sensor DC Bias Voltage

This DC bias voltage is an excellent diagnostic tool. The voltage provides a means of verifying that the amplifier is “turned on.” Typical input/output power supplies will block this DC bias voltage at the output via a blocking capacitor in order to AC couple the signal to readout devices. By “teeing” off the input into a DC volt meter, as shown in Figure 18, the bias voltage can be measured.

While measuring the supply voltage, the bias voltage can be measured after the sensor is plugged in. If the meter stays at supply, something in the system is open or not connected. If the meter reads “0,” something in the system is shorted. If the meter reads within the bias voltage range of the sensor, then the sensor and cabling are functioning properly.

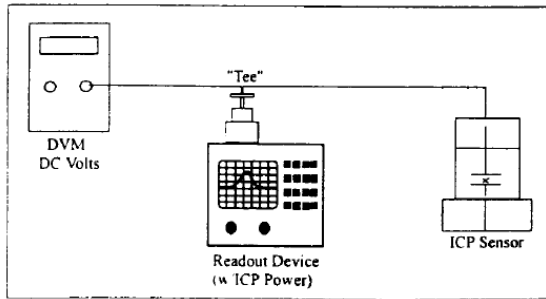

Figure 18. DC Bias Voltage Measurement

10.0 REPAIR/RETURN PROCEDURE

Because of the nature of most IMI instrumentation, field repair is typically NOT recommended and may void any warranty. If factory service is required, contact IMI for a **RETURN MATERIAL AUTHORIZATION (RMA)** number prior to sending equipment to the factory. Please have information available, such as model and serial number. Also, to insure efficient service, be sure to include a written description of the symptoms and problems with the equipment to a local sales representative or distributor, or contact IMI if none are located in your area.

Customers outside the U.S. should consult their local IMI distributor for information on returning equipment. For exceptions, please contact the International Sales department at IMI to request shipping instructions and an

RMA. For assistance, please call **(716) 684-0003**, or fax us at **(716) 684-3823**. You may also receive assistance via e-mail at imi@pcb.com or visit our website at www.pcb.com.

11.0 CUSTOMER SERVICE/WARRANTY

IMI, a division of PCB Piezotronics, guarantees **Total Customer Satisfaction**. If, at any time, for any reason, you are not completely satisfied with any IMI product, IMI will repair, replace or exchange it at no charge. You may also choose to have your purchase price refunded.

IMI instrumentation is warranted against defective material workmanship for 1 year unless otherwise expressly specified. Damage to instruments caused by incorrect power or misapplication, is not covered by warranty. *If there are any questions regarding power, intended application, or general usage, please consult with your local sales contact or distributor.* Batteries or expendable hardware items are not covered by warranty.

IMI offers to all customers, at no charge, 24-hour phone support. This service makes product or application support available to our customers, day or night, seven days a week. When unforeseen problems or emergency situations arise, call the **IMI Hot Line at (716) 684-0003**, and an application specialist will assist you.

Cable Driving Nomograph

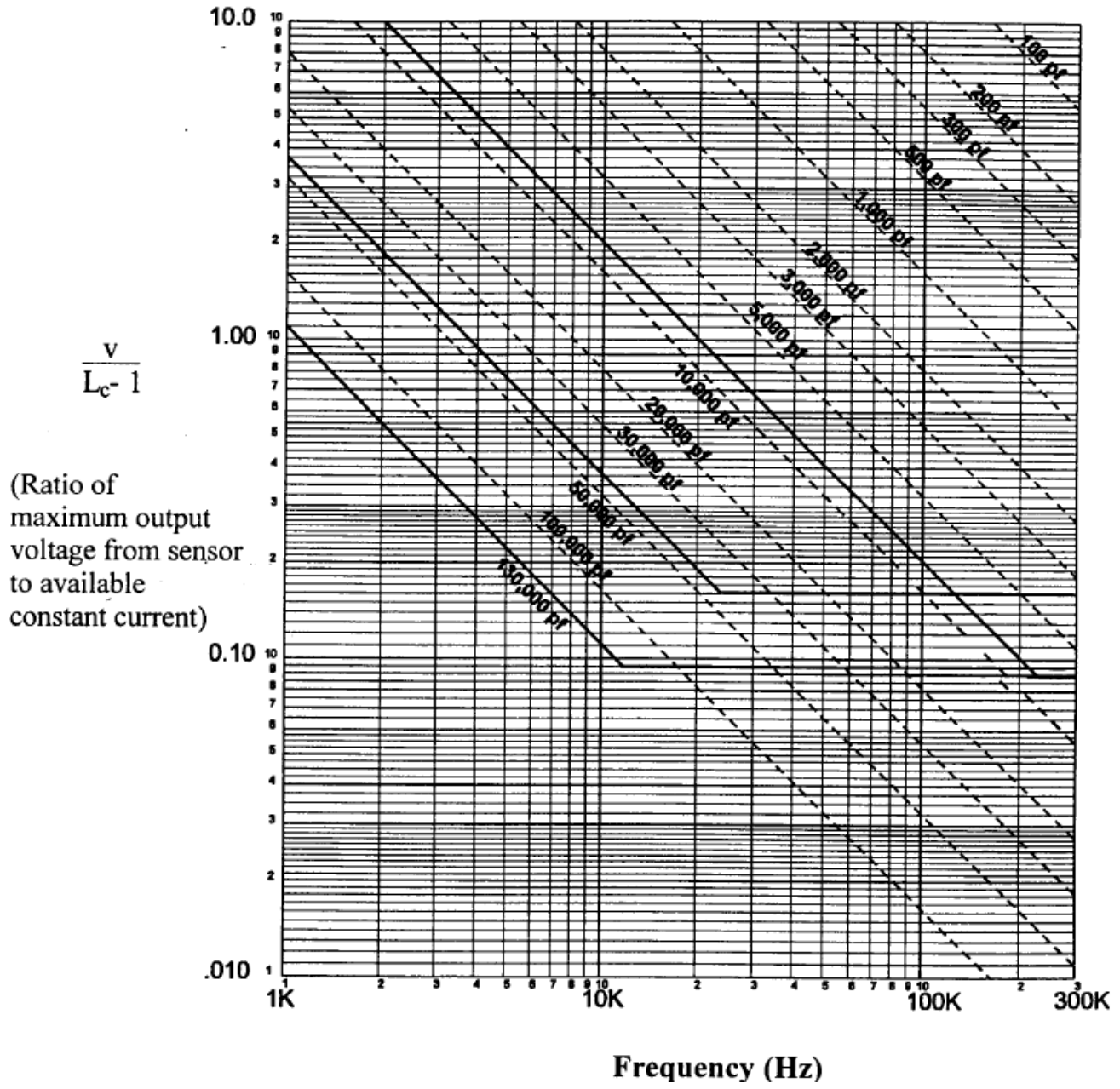

PCB Piezotronics Inc. claims proprietary rights in the information disclosed hereon. Neither it nor any reproduction thereof will be disclosed to others without the written consent of PCB Piezotronics Inc.

70910

SCHEDULE DRAWING

NO MODIFICATIONS PERMITTED WITHOUT REFERENCE TO THE NOTIFIED BODY

REVISIONS		
REV	DESCRIPTION	DIN
NR	RELEASED TO DRAFTING	49059

- 4 SHIELDS TO BE EARTHED AT BARRIER ENDS.
- 3 THE INSTALLER SHALL INSURE THAT THE TRANSDUCER MOUNTING STRUCTURE IS AT THE SAME GROUNDING POTENTIAL AS THE BARRIER GROUND. TOTAL EARTH LOOP IMPEDANCE SHALL BE LESS THAN 1 OHM.
- 2 BARRIER WILL BE MOUNTED IN AN ENCLOSURE THE SUITABILITY OF WHICH WILL BE DETERMINED BY LOCAL AUTHORITIES.

1 ENTITY APPLICATION

BARRIER		I.S. APPARATUS
Voc/Uo	≤	V _{MAX} / UI
Isc/Io	≤	I _{MAX} / II
Ca/Co	>	CI + C _{CABLE}
La/Lo	>	LI + L _{CABLE}
Po	≤	PI (CENELEC ONLY)

BARRIERS WITHIN THE SPECIFIED LIMITATIONS ARE PERMITTED

ENTITY PARAMETERS
EX(M)637XYYYY AND EX(M)638XYYYY SERIES:
U_i = 28V
I_i = 93mA
P_i = 0.65W
C_i = 6.5nF
L_i = 0H

CERTIFIED BY THE APPROPRIATE APPROVAL AUTHORITY FOR CONNECTION TO THE FOLLOWING AREAS:

- NORTH AMERICA:
ZONE 0
AEx ia IIC T4 Ga
- DIV 1
CLASS I, GROUPS A,B,C,D
CLASS II, GROUPS E,F,G
CLASS III
- EUROPE:
ZONE 0
Ex ia IIC T4 Ga

FOR MODELS EX637XYYYY AND EX638XYYYY SERIES, C_i IS SPECIFIED AT A MAXIMUM CABLE LENGTH OF 1000'. FOR SHORTER CABLE LENGTHS, C_i IS DECREASED BY 61pF/FT.

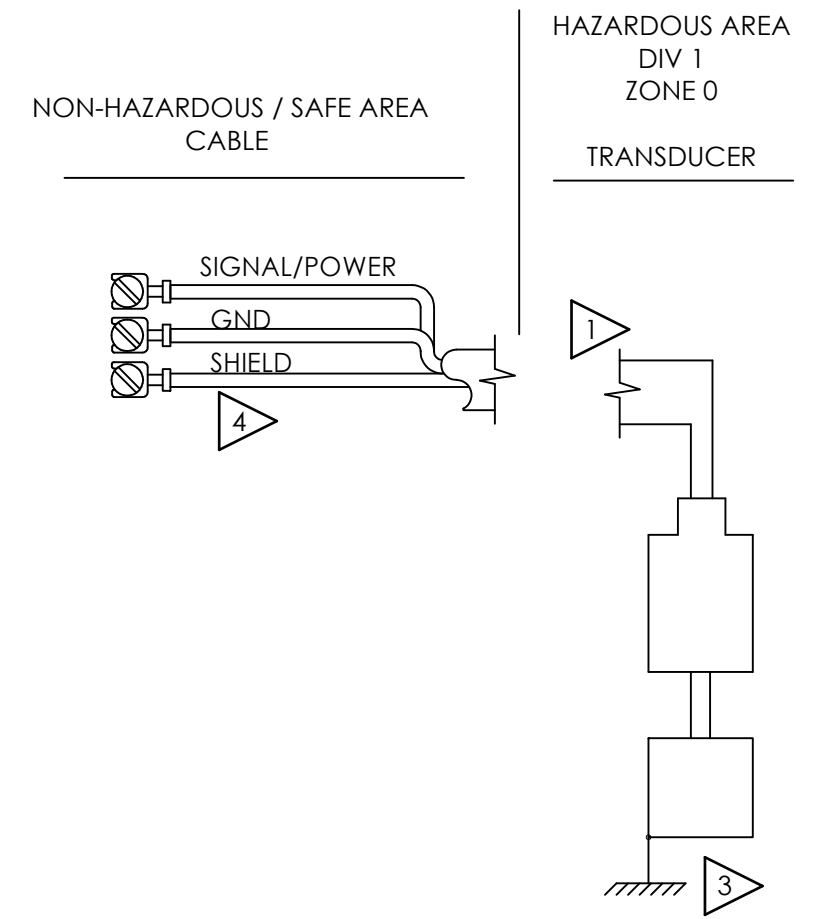
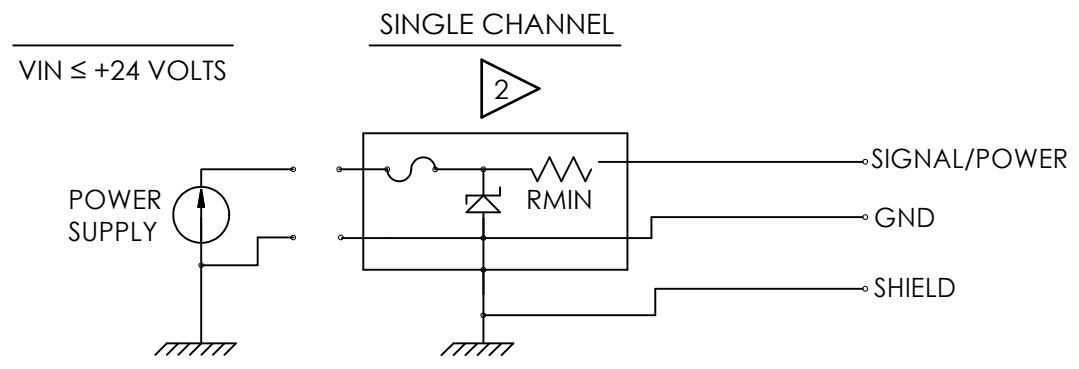

NO CHANGES WITHOUT APPROVAL

<small>UNLESS OTHERWISE SPECIFIED DIMENSIONS ARE IN INCHES DECIMALS X ± .05 XX ± .01 XXX ± .005 XXXX ± .0005 ANGLES ± 2 DEGREES FILLET AND RADII .003 - .005 HEX DIMENSIONS ARE: ≤ .5 + .000 / - .003 > .5 + .000 / - .005 INTERNAL THREAD DEPTH MIN. REMOVE ALL BURRS SHARP = R.000 - R.003</small>	DRAWN			CHECKED			ENGINEER			 3425 WALDEN AVE. DEPEW, NY 14043 (716) 684-0002 E-MAIL: sales@pcb.com CODE IDENT. NO. 52681 SCALE: NONE SHEET 1 OF 2	
	KSR	11/4/19	KSR	11/4/19	GGG	11/4/19	TITLE				
	APPROVAL INTERCONNECTION DIV 1, ZONE 0										DWG. NO.
	70910										70910

70910

PCB Piezotronics Inc. claims proprietary rights in the information disclosed hereon. Neither it nor any reproduction thereof will be disclosed to others without the written consent of PCB Piezotronics Inc.

SCHEDULE DRAWING
NO MODIFICATIONS PERMITTED WITHOUT REFERENCE TO THE NOTIFIED BODY

REVISIONS		
REV	DESCRIPTION	DIN
	-SEE SHEET 1-	

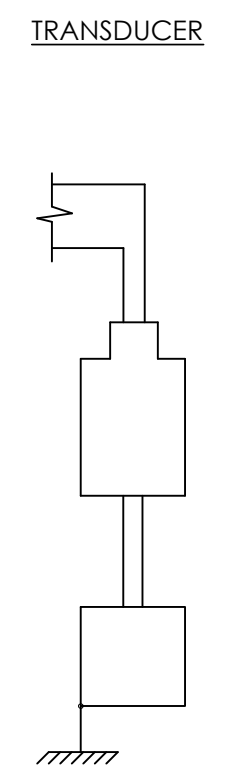
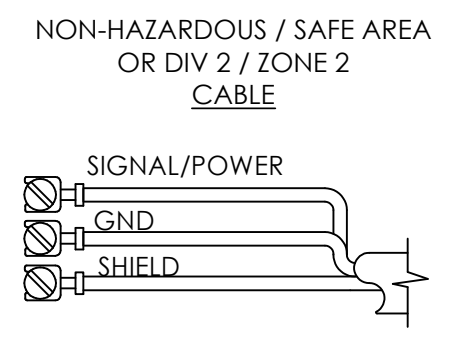
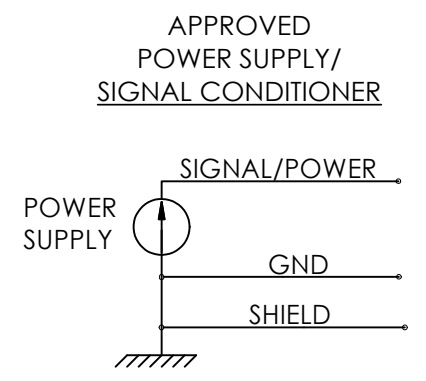

NO CHANGES WITHOUT APPROVAL

- 7.) ⚠ NE PAS DÉBRANCHER LORSQU'UN EMPLACEMENT DANGEREUX EST PRÉSENT
- 6.) ⚠ DO NOT DISCONNECT WHEN HAZARDOUS LOCATION IS PRESENT
- 5.) ⚠ NE PAS DÉBRANCHER LORSQUE ÉNERGÉ
- 4.) ⚠ DO NOT DISCONNECT WHEN ENERGIZED
- 3.) EQUIPMENT CONSISTS OF TRANSIENT PROTECTION DEVICE TO BE SET AT A LEVEL NOT EXCEEDING 140% OF RATED POWER SUPPLY VOLTAGE (30V)
- 2.) FOR GUIDANCE ON CANADIAN INSTALLATION, REFER TO CEC PART I. FOR GUIDANCE ON U.S. INSTALLATION, INSTALL IN ACCORDANCE WITH NEC [ANSI/NFPA70] AND [ANSI/ISA RP12.6]

- 1.) CERTIFIED BY THE APPROPRIATE APPROVAL AUTHORITY FOR CONNECTION TO THE FOLLOWING AREAS:
NORTH AMERICA:
 ZONE 2
 AEx nA IIC T4 Gc
 DIV 2
 CLASS I, GROUPS A,B,C,D

EUROPE:
 ZONE 2
 Ex nA IIC T4 Gc

UNLESS OTHERWISE SPECIFIED
DIMENSIONS ARE IN INCHES
DECIMALS X ± .05
XX ± .01
XXX ± .005
XXXX ± .0005
ANGLES ± 2 DEGREES
FILLETS AND RADII .003 - .005
HEX DIMENSIONS ARE:
≤ .5 + .000 / - .003
> .5 + .000 / - .005
INTERNAL THREAD DEPTH MIN.
REMOVE ALL BURRS
SHARP = R.000 - R.003

DRAWN	CHECKED	ENGINEER
KSR 11/4/19	KSR 11/4/19	GGG 11/4/19
TITLE		
APPROVAL INTERCONNECTION DIV 2, ZONE 2		

PCB PIEZOTRONICS™
3425 WALDEN AVE. DEPEW, NY 14043
(716) 684-0002 E-MAIL: sales@pcb.com

CODE IDENT. NO. 52681	DWG. NO. 70910
SCALE: NONE	SHEET 2 OF 2

INSTRUCTIONS FOR USE – EX(M)637XYYYZ and EX(M)638XYYYZ Series

Model(s)	<p>EX(M)637XYYYZ and EX(M)638XYYYZ Series (M)-Represents an optional Metric Mounting Option X = is a letter that signifies family type. The letter will be from A to Z. YYY = is Two or Three numbers from 00 to 999 that signifies changes to filtering, gain, frequency response etc. Z= is an optional letter A to Z that signifies family type.</p>
Markings	<p>PCB Depew, NY IECEX ETL 19.0034X ITS19ATEX25015 ITS19ATEX45016 X Ex ia IIC T4 Ga, $-196^{\circ}\text{C} \leq T_{amb} \leq 121^{\circ}\text{C}$ Ex nA IIC T4 Gc, $-196^{\circ}\text{C} \leq T_{amb} \leq 121^{\circ}\text{C}$</p> <p>ETL c/us Intertek Listed 5010230 Class I, Div. 1, Groups A,B,C and D Class I, Div. 2, Groups A,B,C and D Class II, Div. 1, Groups E,F and G Class III Class I, Zone 0, AEx ia IIC T4 Ga, Class I, Zone 2, AEx nA IIC T4 Gc, $-196^{\circ}\text{C} \leq T_{amb} \leq 121^{\circ}\text{C}$</p> <p>Install per 70910</p>
Putting Into Service	<p>Powering: All ICP® sensors require constant current excitation for proper operation. For this reason, use only PCB constant-current signal conditioners or other approved constant-current sources. The power supply consists of a current-regulated, 2-20 mA at 18 to 28 VDC source. This power is regulated by a current-limiting circuit, which provides the constant-current excitation required for proper operation of ICP® sensors.</p> <p>In general, battery-powered devices offer versatility for portable, low-noise measurements, whereas line-powered units provide the capability for continuous monitoring. Consult the Vibration Division’s product catalog for more information about signal conditioners.</p> <p>NOTE: <i>Under no circumstances should a voltage be supplied to an ICP® accelerometer without a current-regulating diode or equivalent electrical circuit. This may include ohmmeters, multi-meters and continuity testers.</i></p>
Safe Use	<p>After completing the system setup, switch on the signal conditioner and allow 1 to 2 minutes for the system to stabilize. The meter (or LED) on the signal conditioner should be reading “green.” This indicates proper operation and you may begin taking measurements. If a faulty condition is indicated (red or yellow reading), first check all system connections, then check the functionality of the cable and signal conditioner. If the system still does not operate properly, consult a PCB factory representative.</p> <p>NOTE: <i>Always operate the accelerometer within the limitations listed on the enclosed Specification Sheet. Operating the device outside these parameters can cause temporary or permanent damage to the sensor.</i></p>

Assembling	The EX(M)637XYYYZ and EX(M)638XYYYZ Series have hermetically sealed stainless Steel housings, with a glass-sealed connector, and do not require any assembly. Only mounting to the machine being monitored using standard mounting accessories.
Dismantling	Other than removal from the mounting, there is no disassembly of the sensor required to take it out of service.
Maintenance	Routine maintenance, such as the cleaning of electrical connectors, housings, and mounting surfaces with solutions and techniques that will not harm the physical material of construction, is acceptable.
Servicing	Due to the sophisticated nature of the sensors and associated instrumentation provided by PCB Piezotronics, user servicing or repair is not recommended and, if attempted, may void the factory warranty. However, routine calibration of sensors and associated instrumentation is recommended as this helps build confidence in measurement accuracy and acquired data over time.
Repair	In the event that equipment becomes damaged or ceases to operate, arrangements should be made to return the equipment to PCB Piezotronics for repair. User servicing or repair is not recommended and, if attempted, may void the factory warranty.
Installation	Overview: Sensor must be mounted in order to be put into service. When choosing a mounting method, consider closely both the advantages and disadvantages of each technique. Characteristics like location, ruggedness, amplitude range, accessibility, temperature, and portability are extremely critical. However, the most important and often overlooked consideration is the effect the mounting technique has on the high-frequency performance of the accelerometer. Mounting methods include: Stud mount, adhesive mount, magnetic mount, or probe tip mount. Cabling: Care and attention to cable installation and cable condition is essential as the reliability and accuracy of any measurement system is no better than that of its weakest link. Due to the nature of vibration measurements, all sensor cables will ultimately fatigue and fail. Good installation practice will extend the life of a cable, however, it is highly recommended to keep spare cables on hand to enable continuation of the test in the event of a cable failure.
Adjustment	The sensor is a sealed device and no user adjustments are possible. However, routine calibration of sensors by the manufacturer is recommended as this helps build confidence in measurement accuracy and acquired data.
Danger Areas (for pressure-relief devices)	N/A – not a pressure relief device.
Training Instructions	Industrial sensors to be installed in Hazardous Locations must have this done by trained professionals according to EN/IEC 60079-14 requirements.
Details on Safety of Protection Category	Ex ia is “intrinsic safety”, which limits the energy of sparks and surface temperatures to safe levels. Ex nA is “Non-Sparking”, which ensures that there is no risk of arcing and sparking or hot surfaces during normal operation with a minimum IP protection of IP54.
Entity Parameters and Limits (Values)	Temperature Range: -196°C to +121°C Vmax = 28V, Imax = 93mA, Pi = 0.65W, Ci = 6.5nF, Li = 0μH
Special Conditions of Use	Version Ex nA: The apparatus must be only connect to an equipment whose electrical parameters are compatible with the electrical parameters. The apparatus shall be connected according to drawing 70910 (page 2/2). The connected cable and the connector must provide a minimum ingress protection of IP54, when assessed according to IEC 60079-0 and IEC 60079-15. Unused connector must be fitted with an appropriately rated blanking cover. Device complies with the requirements of the dielectric test per clause 6.3.13 of standard IEC 60079-11.
Essential Characteristics of tools fitted to the system (if any).	N/A – No tools are fitted to the system.
Drawings and Diagrams	70893,70898,70901

Other	ITS 19 ATEX 25015, ITS 19 ATEX 45016 X and ITS IECEx 19.0034X For ATEX protection “ia” – EN 60079-0 + A11:2013 and EN 60079-11:2012 For ATEX protection “nA” – EN 60079-0 + A11:2013 and EN 60079-15:2010
-------	-----------------------------------------------------------------------------------------------------------------------------------------------------------------------------------------------------------------

For IECEx protection “ia” – IEC 60079-0 Ed. 6 and IEC 60079-11 Ed. 6 For IECEx protection “nA” – IEC 60079-0 Ed. 6 and IEC 60079-15 Ed. 4 ETL c/us Intertek Listed – 5010230

Note: Literature (such as the manual or marketing materials) describing the equipment or protective system must not contradict the instructions with regard to safety aspects.

Note: IMI Sensors is a Division of PCB Piezotronics. This Division is wholly contained in the PCB Piezotronics manufacturing facility at 3425 Walden Avenue, Depew, New York. Same address, same manufacturing facility. Some of the documentation contained in the Technical File associated with this application is labeled IMI Sensors, A PCB Piezotronics Div. and some is labeled simply PCB Piezotronics. PCB Piezotronics labeled drawing are higher-level drawings, which are used across multiple divisions, while IMI labeled drawing are specific to IMI models. There will be a mixture of IMI and PCB drawing to support this application, and in reality, they are the same entity however with an associated trade name (IMI) that is recognized by our customer base.

	ENGLISH	SI	
Performance			
Sensitivity(± 10 %)	25 mV/g	2.54 mV/(m/s ²)	[1]
Measurement Range	± 200 g	± 1,962 m/s ²	
Frequency Range(± 5 %)	600 to 24,000 cpm	10 to 400 Hz	[2]
Frequency Range(± 3 dB)	240 to 90,000 cpm	4 to 1,500 Hz	
Filter Type	Low Pass	Low Pass	
Electrical Filter Corner Frequency	1.5 kHz	1.5 kHz	
Electrical Filter Roll-off	12 dB/octave	12 dB/octave	
Resonant Frequency	≥ 1,200 kcpm	≥ 20 kHz	[3]
Broadband Resolution(1 to 10,000 Hz)	1 mg rms	0.01 m/s ² rms	[3]
Non-Linearity	± 1 %	± 1 %	[4]
Transverse Sensitivity	≤ 5 %	≤ 5 %	
Environmental			
Overload Limit(Shock)	1,000 g pk	9,810 m/s ² pk	
Temperature Range	-320 to +250 °F	-196 to +121 °C	
Temperature Response	See Graph	See Graph	[3]
Electrical			
Settling Time(within 1% of bias)	≤ 3 sec	≤ 3 sec	
Discharge Time Constant	0.05 to 0.5 sec	0.05 to 0.5 sec	
Excitation Voltage	18 to 28 VDC	18 to 28 VDC	
Constant Current Excitation	1.6 to 20 mA	1.6 to 20 mA	
Output Impedance	≤ 100 Ohm	≤ 100 Ohm	
Output Bias Voltage	7 to 12 VDC	7 to 12 VDC	
Spectral Noise(1 Hz)	600 µg/√Hz	5,890 (µm/sec ²)/√Hz	
Spectral Noise(10 Hz)	120 µg/√Hz	1,180 (µm/sec ²)/√Hz	[3]
Spectral Noise(100 Hz)	36 µg/√Hz	355 (µm/sec ²)/√Hz	[3]
Spectral Noise(1 kHz)	25 µg/√Hz	250 (µm/sec ²)/√Hz	[3]
Spectral Noise(10 kHz)	6 µg/√Hz	59 (µm/sec ²)/√Hz	
Electrical Isolation	≥ 10 ⁸ Ohm	≥ 10 ⁸ Ohm	
Physical			
Size (Length x Height x Width)	2.25 in x 1 in x 1 in	57.4 mm x 25.4 mm x 25.4 mm	
Weight	6.4 oz	181 gm	[3]
Mounting Thread	1/4-28 UNF	1/4-28 UNF	[5]
Mounting Torque	2 to 5 ft-lb	2.7 to 6.8 Nm	
Sensing Element	Quartz	Quartz	
Sensing Geometry	Shear	Shear	
Housing Material	Stainless Steel	Stainless Steel	
Sealing	Hermetic	Hermetic	[6]
Electrical Connector	2-Pin MIL-C-5015	2-Pin MIL-C-5015	
Electrical Connection Position	Side	Side	

OPTIONAL VERSIONS

Optional versions have identical specifications and accessories as listed for the standard model except where noted below. More than one option may be used.

EX - Hazardous Area Approval- contact factory for specific approvals

M - Metric Mount
Supplied Accessory: Model 081M260 Thru bolt M6x1.0 (1)

NOTES:

[1] Conversion Factor 1g = 9.81 m/s².
 [2] 1Hz = 60 cpm (cycles per minute).
 [3] Typical.
 [4] Zero-based, least-squares, straight line method.
 [5] 1/4-28 has no equivalent in S.I. units.
 [6] Design hydro tested to 1450 psi [10,000 kPa].
 [7] See Models's "Instructions for use" (IFU) for North American Conformity and Certification Statements

SUPPLIED ACCESSORIES:

Model 081A73 Captive mounting bolt 1/4-28 x 1.34" (1)
 Model ICS-6 NIST traceable single axis amplitude response calibration from 10 Hz to upper +/- 3dB point. (1)

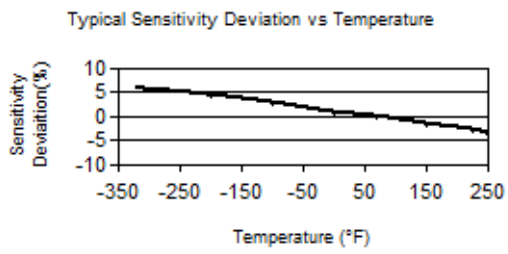

All specifications are at room temperature unless otherwise specified.
 In the interest of constant product improvement, we reserve the right to change specifications without notice.
 ICP® is a registered trademark of PCB Piezotronics, Inc.

Entered: ND	Engineer: BAM	Sales: EGY	Approved: JS	Spec Number:
Date: 01/23/2023	Date: 01/23/2023	Date: 01/23/2023	Date: 01/23/2023	69962

IMI SENSORS
A PCB PIEZOTRONICS DIV.

3425 Walden Avenue, Depew, NY 14043

Phone: 800-959-4464
Fax: 716-684-3823
E-Mail: imi@pcb.com

PCB Piezotronics Inc. claims proprietary rights in the information disclosed hereon. Neither it nor any reproduction thereof will be disclosed to others without the written consent of PCB Piezotronics Inc.

68326

REVISIONS

REV	DESCRIPTION	DIN
A	UPDATED MOUNTING BOLT CALLOUT	48965

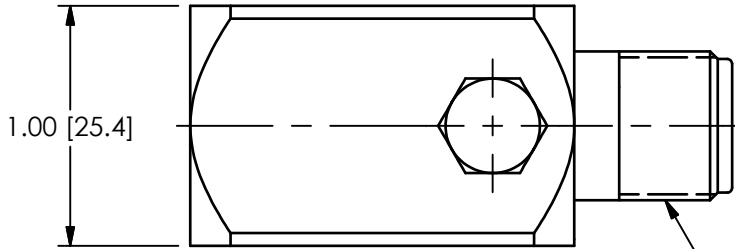

ELECTRICAL CONNECTOR
5/8-24 UNEF - 2A
2 PIN (MIL-C-5015)

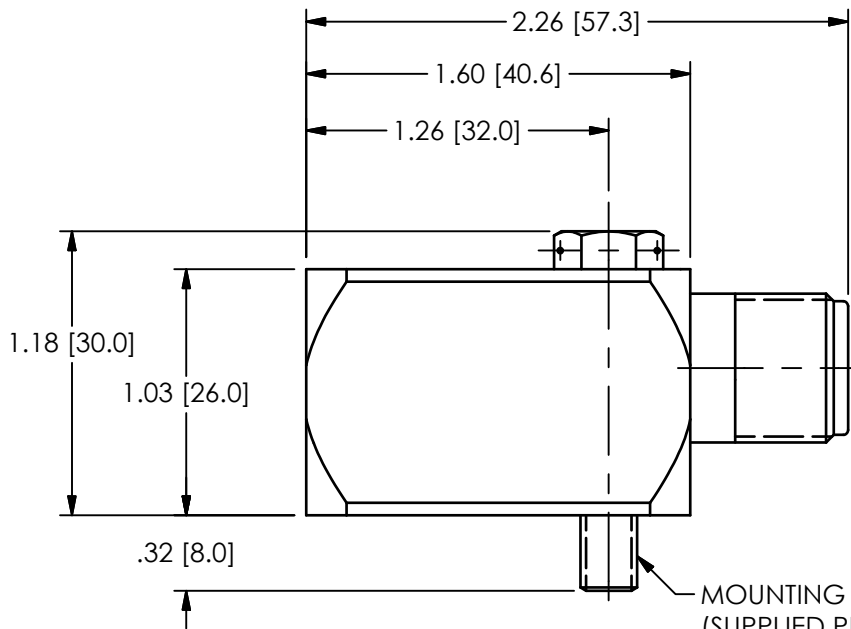

MOUNTING BOLT:
(SUPPLIED PER SPECIFICATION)

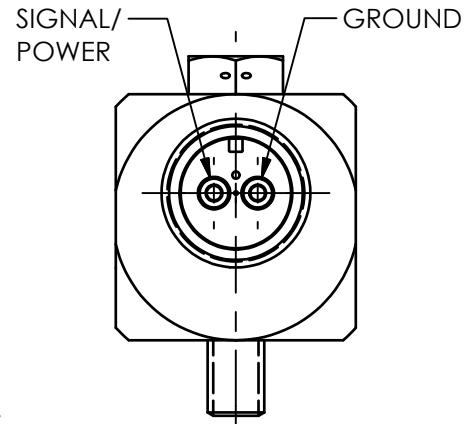

UNLESS OTHERWISE SPECIFIED TOLERANCES ARE:

DRAWN		CHECKED		ENGINEER	
KRM	12/13/18	KRM	12/13/18	RMB	12/13/18

PCB PIEZOTRONICS

3425 WALDEN AVE. DEPEW, NY 14043
(716) 684-0001 E-MAIL: sales@pcb.com

CODE IDENT. NO. 52681	DWG. NO. 68326
--------------------------	--------------------------

SCALE: 1.25X	SHEET 1 OF 1
--------------	--------------

TITLE
OUTLINE DRAWING
CASE ISOLATED
ACCELEROMETER

DIMENSIONS IN INCHES
DECIMALS XX ±.03
XXX ±.010
ANGLES ± 2 DEGREES

DIMENSIONS IN MILLIMETERS [IN BRACKETS]
DECIMALS X ± 0.8
XX ± 0.25
ANGLES ± 2 DEGREES

FILLETS AND RADII
.003 - .005

FILLETS AND RADII
0.07 - 0.13

EU-TYPE EXAMINATION CERTIFICATE

Equipment or Protective System Intended for use in Potentially Explosive Atmospheres Directive
2014/34/EU

1. **EU-Type Examination Certificate Number:** ITS19ATEX25015 **Issue 00**
2. **Product:** ACCELEROMETERS [EX(M)637XYYYY; EX(M)638XYYYY]
3. **Manufacturer:** PCB Piezotronics, Incorporated.
4. **Address:** 3425 Walden Avenue, Depew, NY 14043-2495, USA
5. This product and any acceptable variation thereto is specified in the schedule to this certificate and the documents therein referred to.
6. Intertek Testing and Certification Limited, Notified Body number 0359 in accordance with Article 17 of Directive 2014/34/EU of the European Parliament and of the Council dated 26 February 2014, certifies that the product has been found to comply with the Essential Health and Safety Requirements relating to the design and construction of products intended for use in potentially explosive atmospheres given in Annex II of the Directive.
7. Compliance with the Essential Health and Safety Requirements has been assured by compliance with EN 60079-0:2012+A11:2013 and EN 60079-11:2012 except in respect of those requirements referred to within item 14 of the Schedule.
8. If the sign "X" is placed after the certificate number, it indicates that the product is subject to the special conditions of use specified in the Schedule to this certificate.
9. This EU-Type Examination Certificate relates only to the design and construction of the specified product. Further requirements of the Directive apply to the manufacturing process and supply of this product. These are not covered by this certificate.
10. The marking of the product shall include the following:



II 1 G Ex ia IIC T4 Ga
-196°C ≤ Ta ≤ +121°C

Certification Officer: _____

Kevin J. Wolf
Kevin J. Wolf

Date: _____

16 August 2019

SCHEDULE:

EU-Type Examination Certificate Number: ITS19ATEX25015 Issue 00

11. Description of Equipment or Protective System

The products are Accelerometers with similar electronics.

EX(M)637XYYYY Series Industrial ICP Accelerometer with Top exit connector

EX(M)638XYYYY Series Industrial ICP Accelerometer with Side exit connector

The Accelerometers provide a voltage output when subjected to mechanical motion. They are intended to be fixed installation in the explosive atmosphere and to be supplied by:

field chosen/installed intrinsically safe barrier item for Ex ia.

$U_i = 28V$, $I_i = 93mA$, $P_i = 0.65W$, $C_i = 6.5nF$, $L_i = 0H$

12. Report Number

Intertek Report: 103312845CRT-003a Dated: 8-August-2019.

13. Special Conditions of Certification

(a). Special Conditions of Use

- None

(b). Conditions of Manufacture - Routine Tests

- None

14. Essential Health and Safety Requirements (EHSRs)

The relevant Essential Health and Safety Requirements (EHSRs) have been identified and assessed in Intertek Report: 103312845CRT-003a Dated: 8-August-2019.

15. Drawings and Documents

Title:	Drawing No.:	Rev. Level:	Date:
Technical File SECURITE INTRINSEQUE NON SPARK/ARC ATEX Ex ia ATEX Ex nA EX(M)637XYYYY Series Industrial ICP Accelerometer EX(M)638XYYYY Series Industrial ICP Accelerometer Page 1 of 2	70893	NR	7/24/2019
Technical File SECURITE INTRINSEQUE NON SPARK/ARC ATEX Ex ia ATEX Ex nA EX(M)637XYYYY Series Industrial ICP Accelerometer EX(M)638XYYYY Series Industrial ICP Accelerometer Page 2 of 2	70893	NR	7/24/2019
DESCRIPTIVE NOTICE FOR THE CERTIFICATION OF ACCELEROMETERS (ATEX Descriptive Notice) Page 1 of 1	70894	NR	07/24/19
AMPLIFIER ASSEMBLY Page 1 of 3	70895	NR	7/16/19
AMPLIFIER ASSEMBLY Page 2 of 3	70895	NR	7/16/19
AMPLIFIER ASSEMBLY Page 3 of 3	70895	NR	7/16/19
ETCHING DRAWING MODEL EX(M)637XYYYY SERIES ETCHING DRAWING Page 1 of 2	70897	NR	8/8/19

15. Drawings and Documents (Continued)

Title:	Drawing No.:	Rev. Level:	Date:
ETCHING DRAWING MODEL EX(M)638XXXXY SERIES ETCHING DRAWING Page 2 of 2	70897	NR	8/8/19
APPROVAL INTERCONNECTION DIV 1, ZONE 0 Page 1 of 2	70910	NR	7/27/19
APPROVAL INTERCONNECTION DIV 2, ZONE 2 Page 2 of 2	70910	NR	7/27/19
INSTRUCTIONS FOR USE – EX(M)637XXXXY and EX(M)638XXXXY Series Page 1 of 3	70911	NR	08/01/19
INSTRUCTIONS FOR USE – EX(M)637XXXXY and EX(M)638XXXXY Series Page 2 of 3"	70911	NR	08/01/19
INSTRUCTIONS FOR USE – EX(M)637XXXXY and EX(M)638XXXXY Series Page 3 of 3"	70911	NR	08/01/19
APPROVAL XTAL DRAWING Page 1 of 1"	71165	NR	7/24/19

TYPE EXAMINATION CERTIFICATE

Equipment or Protective System Intended for use in Potentially Explosive Atmospheres Directive
2014/34/EU

1. **Type Examination Certificate Number:** ITS19ATEX45016X Issue 00
2. **Product:** ACCELEROMETERS [EX(M)637XYYYY; EX(M)638XYYYY]
3. **Manufacturer:** PCB Piezotronics, Incorporated.
4. **Address:** 3425 Walden Avenue, Depew, NY 14043-2495, USA
5. This product and any acceptable variation thereto is specified in the schedule to this certificate and the documents therein referred to.
6. Intertek Testing and Certification Limited, certifies that this product has been found to comply with the Essential Health and Safety Requirements relating to the design and construction of the products intended for use in potentially explosive atmospheres given in Annex II of Directive 2014/34/EU of the European Parliament and of the Council, dated 26 February 2014.
7. Compliance with the Essential Health and Safety Requirements has been assured by compliance with EN 60079-0:2012+A11:2013 and EN 60079-15:2010 except in respect of those requirements referred to within item 14 of the Schedule
8. If the sign "X" is placed after the certificate number, it indicates that the product is subject to the special conditions of use specified in the Schedule to this certificate.
9. This Type Examination Certificate relates only to the design of the specified product and not to specific items subsequently manufactured.
10. The marking of the product shall include the following:



II 3 G Ex nA IIC T4 Gc
-196°C ≤ Ta ≤ +121°C

Certification Officer: _____

Kevin J. Wolf
Kevin J. Wolf

Date: _____

16 August 2019

SCHEDULE:

TYPE EXAMINATION CERTIFICATE NUMBER ITS19ATEX45016X Issue 00

11. Description of Equipment or Protective System

The products are Accelerometers with similar electronics.

EX(M)637XYXYZ Series Industrial ICP Accelerometer with Top exit connector

EX(M)638XYXYZ Series Industrial ICP Accelerometer with Side exit connector

The Accelerometers provide a voltage output when subjected to mechanical motion. They are intended to be fixed installation in the explosive atmosphere and to be supplied by:

field chosen/installed intrinsically safe barrier item for Ex ia

or

field chosen/installed supply item for Ex nA.

12. Report Number

Intertek Report: 103312845CRT-003a Dated: 8-August-2019.

13. Conditions of Certification

(a). Special Conditions of Use

- The apparatus must be only connect to an equipment whose electrical parameters are compatible with the electrical parameters. The apparatus shall be connected according to drawing 70910 (page 2/2). The connected cable and the connector must provide a minimum ingress protection of IP54, when assessed according to IEC 60079-0 and IEC 60079-15. Unused connector must be fitted with an appropriately rated blanking cover.

(b). Conditions of Manufacture - Routine Tests

- Dielectric Strength Test Per IEC 60079-15

14. Essential Health and Safety Requirements (EHSRs)

The relevant Essential Health and Safety Requirements (EHSRs) have been identified and assessed in Intertek Report: 103312845CRT-003a Dated: 8-August-2019.

SCHEDULE:

TYPE EXAMINATION CERTIFICATE NUMBER ITS19ATEX45016X Issue 00

15. Drawings and Documents

Title:	Drawing No.:	Rev. Level:	Date:
Technical File SECURITE INTRINSEQUE NON SPARK/ARC ATEX Ex ia ATEX Ex nA EX(M)637XYYYY Series Industrial ICP Accelerometer EX(M)638XYYYY Series Industrial ICP Accelerometer Page 1 of 2	70893	NR	7/24/2019
Technical File SECURITE INTRINSEQUE NON SPARK/ARC ATEX Ex ia ATEX Ex nA EX(M)637XYYYY Series Industrial ICP Accelerometer EX(M)638XYYYY Series Industrial ICP Accelerometer Page 2 of 2	70893	NR	7/24/2019
DESCRIPTIVE NOTICE FOR THE CERTIFICATION OF ACCELEROMETERS (ATEX Descriptive Notice) Page 1 of 1	70894	NR	07/24/19
AMPLIFIER ASSEMBLY Page 1 of 3	70895	NR	7/16/19
AMPLIFIER ASSEMBLY Page 2 of 3	70895	NR	7/16/19
AMPLIFIER ASSEMBLY Page 3 of 3	70895	NR	7/16/19
ETCHING DRAWING MODEL EX(M)637XYYYY SERIES ETCHING DRAWING Page 1 of 2	70897	NR	8/8/19

15. Drawings and Documents (Continued)

Title:	Drawing No.:	Rev. Level:	Date:
ETCHING DRAWING MODEL EX(M)638XYYYY SERIES ETCHING DRAWING Page 2 of 2	70897	NR	8/8/19
APPROVAL INTERCONNECTION DIV 1, ZONE 0 Page 1 of 2	70910	NR	7/27/19
APPROVAL INTERCONNECTION DIV 2, ZONE 2 Page 2 of 2	70910	NR	7/27/19
INSTRUCTIONS FOR USE – EX(M)637XYYYY and EX(M)638XYYYY Series Page 1 of 3	70911	NR	08/01/19
INSTRUCTIONS FOR USE – EX(M)637XYYYY and EX(M)638XYYYY Series Page 2 of 3"	70911	NR	08/01/19
INSTRUCTIONS FOR USE – EX(M)637XYYYY and EX(M)638XYYYY Series Page 3 of 3"	70911	NR	08/01/19
APPROVAL XTAL DRAWING Page 1 of 1"	71165	NR	7/24/19

This authorizes the application of the Certification Mark(s) shown below to the models described in the Product(s) Covered section when made in accordance with the conditions set forth in the Certification Agreement and Listing Report. This authorization also applies to multiple listee model(s) identified on the correlation page of the Listing Report.

This document is the property of Intertek Testing Services and is not transferable. The certification mark(s) may be applied only at the location of the Party Authorized To Apply Mark.

Applicant: PCB Piezotronics, Inc.
Address: 3425 Walden Ave
Depew, NY-14043-2417
Country: USA
Contact: Ms. Carrie Termin
Phone: 716-684-0002 ext. 2206
FAX: NA
Email: ctermin@pcb.com

Manufacturer: PCB Piezotronics, Inc.
Address: 3425 Walden Ave
Depew, NY-14043-2417
Country: USA
Contact: Ms. Carrie Termin
Phone: 716-684-0002 ext. 2206
FAX: NA
Email: ctermin@pcb.com

Party Authorized To Apply Mark: Same as Applicant
Report Issuing Office: Cortland, NY



Control Number: 5010230 **Authorized by:** _____
for L. Matthew Snyder, Certification Manager



This document supersedes all previous Authorizations to Mark for the noted Report Number.

This Authorization to Mark is for the exclusive use of Intertek's Client and is provided pursuant to the Certification agreement between Intertek and its Client. Intertek's responsibility and liability are limited to the terms and conditions of the agreement. Intertek assumes no liability to any party, other than to the Client in accordance with the agreement, for any loss, expense or damage occasioned by the use of this Authorization to Mark. Only the Client is authorized to permit copying or distribution of this Authorization to Mark and then only in its entirety. Use of Intertek's Certification mark is restricted to the conditions laid out in the agreement and in this Authorization to Mark. Any further use of the Intertek name for the sale or advertisement of the tested material, product or service must first be approved in writing by Intertek. Initial Factory Assessments and Follow up Services are for the purpose of assuring appropriate usage of the Certification mark in accordance with the agreement, they are not for the purposes of production quality control and do not relieve the Client of their obligations in this respect.

Intertek Testing Services NA Inc.
545 East Algonquin Road, Arlington Heights, IL 60005
Telephone 800-345-3851 or 847-439-5667 Fax 312-283-1672

Standard(s):	<p>Intrinsically Safe Apparatus And Associated Apparatus For Use In Class 1, 2, 3, Division 1, Hazardous (Classified) Locations [UL 913:2013 Ed.8+R:16Oct2015]</p> <p>Nonincendive Electrical Equipment For Use In Class I And II, Division 2 And Class III, Divisions 1 And 2 Hazardous (Classified) Locations [UL 121201:2017 Ed.9]</p> <p>Explosive Atmospheres – Part 0: Equipment – General Requirements [UL 60079-0:2013 Ed.6+R:20Oct2017]</p> <p>Explosive Atmospheres - Part 11: Equipment Protection By Intrinsic Safety 'i' [UL 60079-11:2013 Ed.6 +R:28Mar2014]</p> <p>Explosive Atmosphere – Part 15: Equipment Protection By Type Of Protection 'N' [UL 60079-15:2013 Ed.4+R:05May2017]</p> <p>Intrinsically Safe And Non-Incendive Equipment For Use In Hazardous Locations (R2016) [CSA C22.2#157:1992 Ed.3+G1;U2]</p> <p>Nonincendive Electrical Equipment For Use In Class I And II, Division 2 And Class III, Divisions 1 And 2 Hazardous (Classified) Locations [CSA C22.2#213:2017 Ed.3]</p>
Product:	<p>Cryogenic Accelerometers For Use In: Class I, Div. 1, GR A, B, C, D Class I, Div. 2, GR A, B, C, D Class II, Div. 1, GR E, F, G Class III Class I, Zone 0, AEx ia IIC T4 Ga Class I, Zone 2, AEx nA IIC T4 Gc -196°C ≤ Ta ≤ 121°C</p>
Brand Name:	<p>IMI Sensors a Division of PCB Piezotronic, IMI Vibration Sensors</p>
Models:	<p>EX637 Followed By A to Z; Followed By 00 to 999; Followed By A to Z. EXM637 Followed By A to Z; Followed By 00 to 999; Followed By A to Z. EX638 Followed By A to Z; Followed By 00 to 999; Followed By A to Z. EXM638 Followed By A to Z; Followed By 00 to 999; Followed By A to Z.</p>



IECEX Certificate of Conformity

INTERNATIONAL ELECTROTECHNICAL COMMISSION IEC Certification Scheme for Explosive Atmospheres

for rules and details of the IECEX Scheme visit www.iecex.com

Certificate No.: IECEX ETL 19.0034X Issue No: 0 Certificate history:
Issue No. 0 (2019-08-22)

Status: **Current**

Page 1 of 3

Date of Issue: **2019-08-22**

Applicant: **PCB Piezotronics, Incorporated.**
3425 Walden Avenue, Depew, NY 14043-2495
United States of America

Equipment: **Accelerometers: EX(M)637XYYYY; EX(M)638XYYYY**
Optional accessory:

Type of Protection: **Intrinsic Safety 'ia' Non-Sparking 'nA'**

Marking:
Ex ia IIC T4 Ga
Ex nA IIC T4 Gc
-196° ≤ Ta ≤ 121°C
IECEX ETL 19.0034X

*Approved for issue on behalf of the IECEX
Certification Body:*

Kevin J. Wolf

Position:

Certification Officer

*Signature:
(for printed version)*

Date:

1. This certificate and schedule may only be reproduced in full.
2. This certificate is not transferable and remains the property of the issuing body.
3. The Status and authenticity of this certificate may be verified by visiting the [Official IECEX Website](#).

Certificate issued by:

Intertek
3933 US Route 11 South
Cortland NY 13045-2995
United States of America





IECEX Certificate of Conformity

Certificate No: IECEX ETL 19.0034X Issue No: 0
Date of Issue: **2019-08-22** Page 2 of 3
Manufacturer: **PCB Piezotronics, Incorporated.**
3425 Walden Avenue, Depew, NY 14043-2495
United States of America

Additional Manufacturing location(s):

This certificate is issued as verification that a sample(s), representative of production, was assessed and tested and found to comply with the IEC Standard list below and that the manufacturer's quality system, relating to the Ex products covered by this certificate, was assessed and found to comply with the IECEX Quality system requirements. This certificate is granted subject to the conditions as set out in IECEX Scheme Rules, IECEX 02 and Operational Documents as amended.

STANDARDS:

The apparatus and any acceptable variations to it specified in the schedule of this certificate and the identified documents, was found to comply with the following standards:

IEC 60079-0 : 2011 Edition:6.0	Explosive atmospheres - Part 0: General requirements
IEC 60079-11 : 2011 Edition:6.0	Explosive atmospheres - Part 11: Equipment protection by intrinsic safety "i"
IEC 60079-15 : 2010 Edition:4	Explosive atmospheres - Part 15: Equipment protection by type of protection "n"

*This Certificate **does not** indicate compliance with electrical safety and performance requirements other than those expressly included in the Standards listed above.*

TEST & ASSESSMENT REPORTS:

A sample(s) of the equipment listed has successfully met the examination and test requirements as recorded in

Test Report:

US/ETL/ExTR19.0041/00

Quality Assessment Report:

NL/DEK/QAR14.0004/02 NL/DEK/QAR14.0004/03



IECEX Certificate of Conformity

Certificate No: IECEx ETL 19.0034X

Issue No: 0

Date of Issue: **2019-08-22**

Page 3 of 3

Schedule

EQUIPMENT:

Equipment and systems covered by this certificate are as follows:

The products are Accelerometers with similar electronics.

EX(M)637XYYYZ Series Industrial ICP Accelerometer with Top exit connector

EX(M)638XYYYZ Series Industrial ICP Accelerometer with Side exit connector

The Accelerometers provide a voltage output when subjected to mechanical motion. They are intended to be fixed installation in the explosive atmosphere and to be supplied by field chosen/installed intrinsically safe barrier item.

When used in Zone 2

The Accelerometers provide a voltage output when subjected to mechanical motion. They are intended to be fixed installation in the explosive atmosphere and to be supplied by field chosen/installed supply item.

SPECIFIC CONDITIONS OF USE: YES as shown below:

Version Ex ia:

None

Version Ex nA:

The apparatus must be only connect to an equipment whose electrical parameters are compatible with the electrical parameters. The apparatus shall be connected according to drawing 70910 (page 2/2). The connected cable and the connector must provide a minimum ingress protection of IP54, when assessed according to IEC 60079-0 and IEC 60079-15. Unused connector must be fitted with an appropriately rated blanking cover.

Routine Dielectric testing in accordance with IEC 60079-15

Annex

[Annex 1 IECEx ETL 19.0034X.pdf](#)



IECEX Certificate of Conformity

Certificate No:	IECEX ETL 19.0034X	Issue No. 0
Annex No. 1		

Technical Documents			
Title:	Drawing No.:	Rev. Level:	Date:
*Technical File SECURITE INTRINSEQUE NON SPARK/ARC IECEX Ex ia IECEX Ex nA EX(M)637XYYYY Series Industrial ICP Accelerometer EX(M)638XYYYY Series Industrial ICP Accelerometer Page 1 of 2	70898	NR	7/24/2019
*Technical File SECURITE INTRINSEQUE NON SPARK/ARC IECEX Ex ia IECEX Ex nA EX(M)637XYYYY Series Industrial ICP Accelerometer EX(M)638XYYYY Series Industrial ICP Accelerometer Page 2 of 2	70898	NR	7/24/2019
*DESCRIPTIVE NOTICE FOR THE CERTIFICATION OF ACCELEROMETERS (IECEX Descriptive Notice) Page 1 of 1	70899	NR	07/24/19
*AMPLIFIER ASSEMBLY Page 1 of 3	70895	NR	7/16/19
*AMPLIFIER ASSEMBLY Page 2 of 3	70895	NR	7/16/19
*APPROVAL BOM	70895	NR	7/16/19

Certificate issued by:

Intertek
3933 US Route 11 South
Cortland NY 13045-2995
United States of America

intertek
Total Quality. Assured.



IECEX Certificate of Conformity

Certificate No:	IECEX ETL 19.0034X	Issue No. 0
Annex No. 1		

Technical Documents			
Title:	Drawing No.:	Rev. Level:	Date:
Page 3 of 3			
*APPROVAL ASSEMBLY EX(M)637XYYYZ SERIES Page 1 of 2	70895	NR	7/16/19
* APPROVAL ASSEMBLY EX(M)638XYYYZ SERIES Page 2 of 2	70895	NR	7/16/19
*ETCHING DRAWING MODEL EX(M)637XYYYZ SERIES ETCHING DRAWING Page 1 of 2	70900	NR	8/8/19
*ETCHING DRAWING MODEL EX(M)638XYYYZ SERIES ETCHING DRAWING Page 2 of 2	70900	NR	8/8/19
*APPROVAL INTERCONNECTION DIV 1, ZONE 0 Page 1 of 2	70910	NR	7/27/19
*APPROVAL INTERCONNECTION DIV 2, ZONE 2 Page 2 of 2	70910	NR	7/27/19
*INSTRUCTIONS FOR USE – EX(M)637XYYYZ and EX(M)638XYYYZ Series Page 1 of 3	70911	NR	08/01/19
*INSTRUCTIONS FOR USE – EX(M)637XYYYZ and EX(M)638XYYYZ Series	70911	NR	08/01/19

Certificate issued by:

Intertek
3933 US Route 11 South
Cortland NY 13045-2995
United States of America

intertek
Total Quality. Assured.



IECEX Certificate of Conformity

Certificate No:	IECEX ETL 19.0034X	Issue No. 0
Annex No. 1		

Technical Documents			
Title:	Drawing No.:	Rev. Level:	Date:
Page 2 of 3"			
*INSTRUCTIONS FOR USE – EX(M)637XXXXZ and EX(M)638XXXXZ Series Page 3 of 3"	70911	NR	08/01/19
*APPROVAL XTAL DRAWING Page 1 of 1"	71165	NR	7/24/19

*Note: An * is included before the title of documents that are new or revised.*

Certificate issued by:

Intertek
3933 US Route 11 South
Cortland NY 13045-2995
United States of America

intertek
Total Quality. Assured.

Test Reports	EMC Reports Safety Reports	GM29028c, GM29030c, GM29032c, GM29043c, GM29045c, GM29047c GM29029s, GM29031s, GM29033s, GM29044s, GM29046s, GM29048s
---------------------	-------------------------------	--------------------------------------------------------------------------------------------------------------------------

I, the undersigned, hereby declare that the equipment specified above conforms to the above Directive(s) Standard(s)

Place: Depew, NY **Date:** 1/5/2023

Signature: 

Name: Wendy Willard

Title: Regulatory Affairs and Product Certification Specialist

UK Declaration of Conformity PS023UK

In Accordance with ISO/IEC 17050

Manufacturer:
PCB Piezotronics, Inc.
3425 Walden Avenue
Depew, New York 14043
USA

Authorized UK Representative:
PCB Piezotronics Ltd
Business and Technology Center
Bessemer Drive
Stevenage
Hertfordshire
SG1 2DX United Kingdom



Certifies that type of equipment: ICP® Sensors

Whose Product Models Include: Y-Y1X-Xyxxx Series ICP Pressure Sensors
Y-Y2X-Xyxxx Series ICP Force Sensors
Y-Y3X-Xyxxx Series ICP Vibration Sensors
Y-Y6X-Xyxxx Series ICP Industrial Vibration Sensors
Y-Y74X-Xyxxx Series ICP Strain Sensors

Note: "Y-Y" is a placeholder for up to 6 possible letter prefixes depending on possible implemented options (letter prefixes may be part of the model number).
"X-X" is a placeholder for one to five numbers.
"y" is a placeholder for one letter.
"xxx" is a placeholder for up to three numbers and/or letters.

For example: HT622A01Industrial Vibe Sensor or WTLBM356A15 Vibration Sensor

These letters and numbers are included in the model numbers of the series. For details, see the related data sheets.

This declaration is applicable to all sensors of the above series, which have the UKCA mark on their data sheets and where those data sheets refer to this Declaration of Conformity. The data sheets for all model numbers referenced above, which include the UKCA mark on such data sheets and refer to this Declaration of Conformity are hereby incorporated by reference into this Declaration.

Conform to the following UK Statutory Requirements when installed per product documentation:

Electromagnetic Compatibility Regulations 2016 (SI 2016 No. 1091) Electrical Equipment (Safety) Regulations 2016
The Restriction of the Use of Certain Hazardous Substances in Electrical and Electronic Equipment Regulations 2012 (SI 2012 No. 3032)

Designated Standards to which Conformity is Declared:

Designated Standards	EN 61326-1:2013 EN 61326-2-3:2013 EN 61010-1:2010 EN 61010-1:2010/A1:2019/AC:2019-04 EN 61010-1:2010/A1:2019 EN 63000:2018	Electrical Equipment for Measurement, Control and Laboratory Use- EMC requirements - Part 1: General requirements Electrical equipment for measurement, control and laboratory use - EMC requirements - Part 2-3: Particular requirements - Test configuration, operational conditions and performance criteria for transducers with integrated or remote signal conditioning Safety requirements for electrical equipment for measurement, control, and laboratory use - Part 1: General requirements Technical documentation for the assessment of electrical and electronic products with respect to the restriction of hazardous substances (IEC 63000:2016)
Emissions Test Standards	EN 55011:2016, EN 55011:2016/A1:2017 EN 55011:2016/A11:2020	Industrial, scientific and medical(ISM) radio frequency equipment Electromagnetic disturbance characteristics- Limits and methods of Measurement Class B

Immunity Test Standards	EN 61000-6-1:2007 EN 61000-6-2:2005 EN 61000-6-2:2005/ AC:2005	Electromagnetic Compatibility (EMC) - Generic standards — Immunity for residential, commercial and light-industrial environments Electromagnetic compatibility (EMC) — Part 6-2: Generic standards — Immunity for industrial environments
Test Reports	EMC Reports Safety Reports	GM29028c, GM29030c, GM29032c, GM29043c, GM29045c, GM29047c GM29029s, GM29031s, GM29033s, GM29044s, GM29046s, GM29048s

I, the undersigned, hereby declare that the equipment specified above conforms to the above Directive(s) Standard(s)

Place: Depew, NY **Date:** 1/5/2023

Signature:



Name: Wendy Willard

Title: Regulatory Affairs and Product Certification Specialist