



**Model EX686B01**

**Intrinsically-safe USB programmable electronic vibration switch with 2-pin MIL-C-5015 connector**

**Installation and Operating Manual**

**For assistance with the operation of this product,  
contact the PCB Piezotronics, Inc.**

**Toll-free: 800-959-4464**

**24-hour SensorLine: 716-684-0001**

**Fax: 716-684-3823**

**E-mail: [imi@pcb.com](mailto:imi@pcb.com)**

**Web: [www.imi-sensors.com](http://www.imi-sensors.com)**



## Repair and Maintenance

PCB guarantees Total Customer Satisfaction through its “Lifetime Warranty Plus” on all Platinum Stock Products sold by PCB and through its limited warranties on all other PCB Stock, Standard and Special products. Due to the sophisticated nature of our sensors and associated instrumentation, **field servicing and repair is not recommended and, if attempted, will void the factory warranty.**

Beyond routine calibration and battery replacements where applicable, our products require no user maintenance. Clean electrical connectors, housings, and mounting surfaces with solutions and techniques that will not harm the material of construction. Observe caution when using liquids near devices that are not hermetically sealed. Such devices should only be wiped with a dampened cloth—never saturated or submerged.

In the event that equipment becomes damaged or ceases to operate, our Application Engineers are here to support your troubleshooting efforts 24 hours a day, 7 days a week. Call or email with model and serial number as well as a brief description of the problem.

## Calibration

Routine calibration of sensors and associated instrumentation is necessary to maintain measurement accuracy. We recommend calibrating on an annual basis, after exposure to any extreme environmental influence, or prior to any critical test.

PCB Piezotronics is an ISO-9001 certified company whose calibration services are accredited by A2LA to ISO/IEC 17025, with full traceability to SI through N.I.S.T. In addition to our standard calibration services, we also offer specialized tests, including: sensitivity at elevated or cryogenic temperatures, phase response, extended high or low frequency response, extended range, leak testing, hydrostatic pressure testing, and others. For more information, contact your local PCB Piezotronics distributor, sales representative, or factory customer service representative.

## Returning Equipment

If factory repair is required, our representatives will provide you with a Return Material Authorization (RMA) number, which we use to reference any information you have already provided and expedite the repair process. This number should be clearly marked on the outside of all returned package(s) and on any packing list(s) accompanying the shipment.

## Contact Information

PCB Piezotronics, Inc.  
3425 Walden Ave.  
Depew, NY14043 USA  
Toll-free: (800) 828-8840  
24-hour SensorLine: (716) 684-0001  
General inquiries: [info@pcb.com](mailto:info@pcb.com)  
Repair inquiries: [rma@pcb.com](mailto:rma@pcb.com)

For a complete list of distributors, global offices and sales representatives, visit our website, [www.pcb.com](http://www.pcb.com).

## Safety Considerations

This product is intended for use by qualified personnel who recognize shock hazards and are familiar with the precautions required to avoid injury. While our equipment is designed with user safety in mind, the protection provided by the equipment may be impaired if equipment is used in a manner not specified by this manual.

Discontinue use and contact our 24-Hour Sensorline if:

- Assistance is needed to safely operate equipment
- Damage is visible or suspected
- Equipment fails or malfunctions

For complete equipment ratings, refer to the enclosed specification sheet for your product.

## Definition of Terms and Symbols

The following symbols may be used in this manual:



### DANGER

Indicates an immediate hazardous situation, which, if not avoided, may result in death or serious injury.

**CAUTION**

Refers to hazards that could damage the instrument.

**NOTE**

Indicates tips, recommendations and important information. The notes simplify processes and contain additional information on particular operating steps.

**The following symbols may be found on the equipment described in this manual:**



This symbol on the unit indicates that high voltage may be present. Use standard safety precautions to avoid personal contact with this voltage.



This symbol on the unit indicates that the user should refer to the operating instructions located in the manual.



This symbol indicates safety, earth ground.



PCB工业监视和测量设备 - 中国RoHS2公布表

PCB Industrial Monitoring and Measuring Equipment - China RoHS 2 Disclosure Table

部件名称	有害物质					
	铅 (Pb)	汞 (Hg)	镉 (Cd)	六价铬 (Cr(VI))	多溴联苯 (PBB)	多溴二苯醚 (PBDE)
住房	0	0	0	0	0	0
PCB板	X	0	0	0	0	0
电气连接器	0	0	0	0	0	0
压电晶体	X	0	0	0	0	0
环氧	0	0	0	0	0	0
铁氟龙	0	0	0	0	0	0
电子	0	0	0	0	0	0
厚膜基板	0	0	X	0	0	0
电线	0	0	0	0	0	0
电缆	X	0	0	0	0	0
塑料	0	0	0	0	0	0
焊接	X	0	0	0	0	0
铜合金/黄铜	X	0	0	0	0	0
本表格依据 SJ/T 11364 的规定编制。						
0：表示该有害物质在该部件所有均质材料中的含量均在 GB/T 26572 规定的限量要求以下。						
X：表示该有害物质至少在该部件的某一均质材料中的含量超出 GB/T 26572 规定的限量要求。						
铅是欧洲RoHS指令2011/65/ EU附件三和附件四目前由于允许的豁免。						

CHINA RoHS COMPLIANCE

Component Name	Hazardous Substances					
	Lead (Pb)	Mercury (Hg)	Cadmium (Cd)	Chromium VI Compounds (Cr(VI))	Polybrominated Biphenyls (PBB)	Polybrominated Diphenyl Ethers (PBDE)
Housing	O	O	O	O	O	O
PCB Board	X	O	O	O	O	O
Electrical Connectors	O	O	O	O	O	O
Piezoelectric Crystals	X	O	O	O	O	O
Epoxy	O	O	O	O	O	O
Teflon	O	O	O	O	O	O
Electronics	O	O	O	O	O	O
Thick Film Substrate	O	O	X	O	O	O
Wires	O	O	O	O	O	O
Cables	X	O	O	O	O	O
Plastic	O	O	O	O	O	O
Solder	X	O	O	O	O	O
Copper Alloy/Brass	X	O	O	O	O	O

This table is prepared in accordance with the provisions of SJ/T 11364.

O: Indicates that said hazardous substance contained in all of the homogeneous materials for this part is below the limit requirement of GB/T 26572.

X: Indicates that said hazardous substance contained in at least one of the homogeneous materials for this part is above the limit requirement of GB/T 26572.

Lead is present due to allowed exemption in Annex III or Annex IV of the European RoHS Directive 2011/65/EU.



---

**Operating Guide with Enclosed Warranty Information**

3425 Walden Avenue, Depew, New York 14043-2495

Phone (716) 684-0003

Fax (716) 684-3823

Toll Free Line 1-800-959-4IMI

MANUAL NUMBER: 40112

MANUAL REVISION: **G**

ECO: **49766**

**Table of Contents**

---

Introduction .....	Page 3
General Features	
Operating Principles .....	Page 4
Benefits of Solid State Relays	
Installation.....	Page 5
Direct Adhesive Mount	
Standard Stud Mount	
Adhesive Stud Mount	
Magnetic Mount	
Wiring.....	Page 9
Legend	
Indicating a High Level of Vibration in a Motor	
Indicating High Levels of Vibration Simultaneously in Series (Such as Fan & Motor)	
Constant Siren Alarming in the Event of High Vibration Levels	
Two Switches in Parallel to Monitor Two Axes Simultaneously on Same Motor	
Three Switches in Parallel to Monitor Three Motors Simultaneously	
Automatic Machinery Shutdown Using an External Electromechanical Relay	
Automatic Machinery Shutdown Using External Electromechanical Relay While Monitoring 2 Axes	
Switch and External Latching for Automatic Machinery Shutdown	
Both Alarm Siren and Automatic Machinery Shutdown Using Two Switches	
Automatic Machinery Shutdown Based on Normally Open Solid State Relay	
Automatic Machinery Shutdown of a Three Phase Electrical Motor Based on a N.O. Solid-State Relay	
Programming Software .....	Page 21
Program Installation	
Running the Software	
Programming Sections	
Reading and Writing Parameters	
Parameter Options	
Execution of Delays	
Magnetically Adjustable Vibration Threshold (MAVT™) .....	Page 29
MAVT™ Procedure	
Factory-Programmed Ordering Guide .....	Page 30
Battery-Powered Signal Conditioner .....	Page 31
Calibration Cable .....	Page 31
Magnet Clip.....	Page 31
Cable Ordering Information .....	Page 32
ESD Sensitivity .....	Page 33
Warranty, Service & Return Procedure .....	Page 34
Customer Service .....	Page 34

## **Introduction**

---

The 686-Series Smart Vibration Switch is a low-cost electronic vibration switch designed to monitor vibration levels on rotating machinery (ie. fans and cooling towers) and trip an alarm or shut down machinery when a specified vibration limit is exceeded. An onboard accelerometer with precision, microprocessor-controlled electronics ensures reliable operation and accuracy. The switch contains a two-pin MIL connector for easy drop-in replacement of mechanical vibration switches and a reliable solid state relay. Multiple units can be installed in a loop configuration for economical installation and expanded protection of critical machinery. This versatile switch can be used to replace more expensive electronic vibration switches where separate vibration output is not required and to replace troublesome mechanical vibration switches.

Every Smart Switch is factory-programmed. See Page 28 for more information.

## **General Features**

- Fully USB-programmable from any PC (with optional USB Programmer Kit).
- Hermetically-sealed, stainless steel housing for use in corrosive environments.
- Imbedded piezoelectric accelerometer for improved accuracy and frequency response.
- Small footprint and single ¼-28 stud mounting.
- Solid state (AC/DC) relay.
- Universal AC or DC power.
- Magnetically Adjustable Vibration Threshold (MAVT™).
- Connects with industry standard MIL-C-5015 connector or integral cable.
- Programmable features
  - Alarm threshold level
  - Normally Open (NO) or Normally Closed (NC) relay
  - Latching or non-latching relay
  - Delays
    - Power on
    - Startup
    - Operational
  - Residual vibration level
- Intrinsically-safe versions available (EX prefix)
  - CSA



## Operating Principles

The Smart Switch operates over just two wires. It installs in series with any load (ie. annunciator, PLC or relay coil). To energize itself, the vibration switch scavenges power from the load's power source. When the alarm threshold is exceeded, the switch is activated and the load's power circuit is completed to facilitate the desired alarm or shutdown.

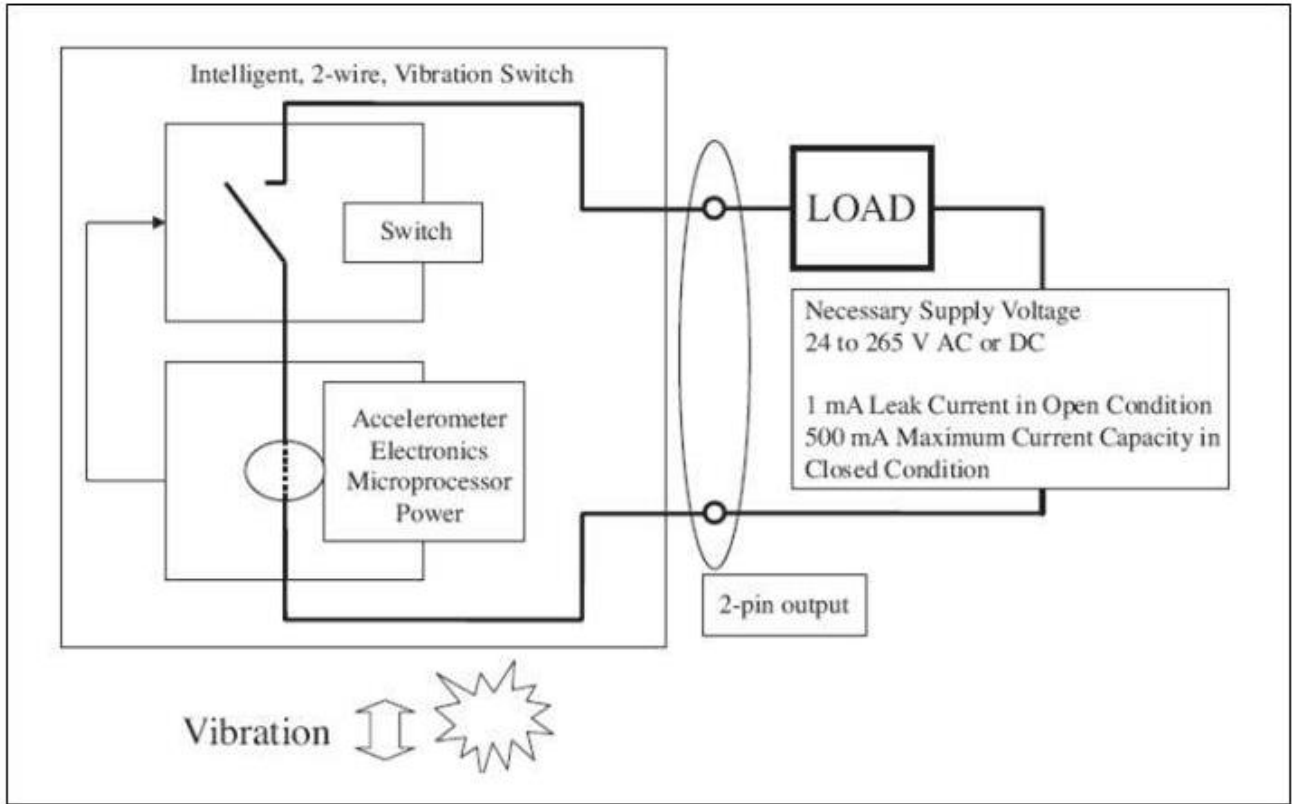

Figure 1 – Block Diagram

## Benefits of Solid State Relays

A solid state relay is an electronic component that functions in the same way as an electromechanical relay, but without any moving parts. A solid state relay offers the most reliable switch action, especially for vibration applications where moving relay components run a greater risk of malfunction. They are purely electronic devices composed of a low current control side and a high current load side for switching action.

## Installation

---

When choosing a mounting method, consider closely the advantages and disadvantages of each technique. Typical mounting types are stud, direct adhesive, adhesive mounting base and magnetic mounting base.

Note: For a complete list of product specifications, see the “Specification Sheet” and “Outline Drawing” at the end of this Manual.

### **Direct Adhesive Mount Procedure**

For restrictions of space or for convenience, most sensors (with the exception of integral stud models) can be adhesive-mounted directly to the machine surface.

- Step 1: Prepare a smooth, flat mounting surface. A minimum surface finish of 63  $\mu\text{in}$  (0.0016 mm) generally works best.
- Step 2: Place a small portion of adhesive on the underside of the sensor. Firmly press down on the top of the assembly to displace any adhesive. Be aware that excessive amounts of adhesive can make sensor removal difficult.

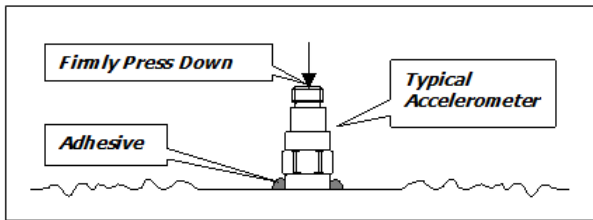

**Figure 2 – Direct Adhesive Mounting**

### Standard Stud Mount Procedure

This mounting technique requires smooth, flat contact surfaces for proper operation and is recommended for permanent and/or secure installations. Stud mounting is also recommended when testing at high frequencies.

Note: Do not attempt mounting on curved, rough or uneven surfaces, as the potential for misalignment and limited contact surface may significantly reduce the sensor's upper operating frequency range.

	¼-28 Stud	¼-28 Captive Screw
A (in)	0.250	0.250
B (in)	0.350	0.350
Torque (ft-lb)	2 to 5	2 to 5

- Step 1: First, prepare a smooth, flat mounting surface and then drill and tap a mounting hole in the center of this area. A precision-machined mounting surface with a minimum finish of 63 µin (0.0016 mm) is recommended. (If it is not possible to properly prepare the machine surface, consider using an adhesive mounting pad as a possible alternative.) Inspect the area, checking that there are no burrs or other foreign particles interfering with the contact surface.
- Step 2: Wipe clean the mounting surface and spread on a light film of grease, oil or similar coupling fluid prior to installation. Adding a coupling fluid improves vibration transmissibility by filling small voids in the mounting surface and increasing the mounting stiffness. For semi-permanent mounting, substitute epoxy or another type of adhesive.
- Step 3: Hand-tighten the sensor/mounting stud to the machine, and then secure the sensor with a torque wrench to the mounting surface by applying the recommended mounting torque (see enclosed specification data sheet for proper mounting torque). It is important to use a torque wrench during this step. Under-torquing the sensor may not adequately couple the device; over-torquing may result in stud failure and possibly permanent damage.

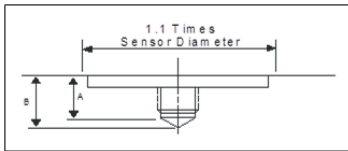

Figure 3 – Mounting Surface Preparation

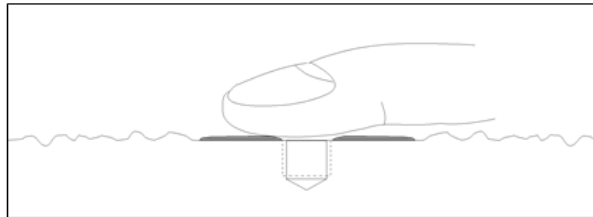

Figure 4 – Mounting Surface Lubrication

### **Adhesive Stud Mount Procedure**

Adhesive mounting is often used for temporary installation or when the machine surface cannot be adequately prepared for stud mounting. Adhesives like hot glue or wax work well for temporary mounts; two-part epoxies and quick-bonding gels provide a more permanent mount.

---

Note: Adhesively mounted sensors often exhibit a reduction in high-frequency range. Generally, smooth surfaces and stiff adhesives provide the best frequency response. Contact the factory for recommended epoxies.

---

This method involves attaching a base to the machine surface, then securing the sensor to the base. This allows for easy removal of the accelerometer.

- Step 1: Prepare a smooth, flat mounting surface. A minimum surface finish of 63  $\mu\text{in}$  (0.0016 mm) generally works best.
- Step 2: Stud-mount the sensor to the appropriate adhesive mounting base according to the guidelines set forth in Steps 2 and 3 of the Standard Stud Mount Procedure.
- Step 3: Place a small portion of adhesive on the underside of the mounting base. Firmly press down on the assembly to displace any extra adhesive remaining under the base.

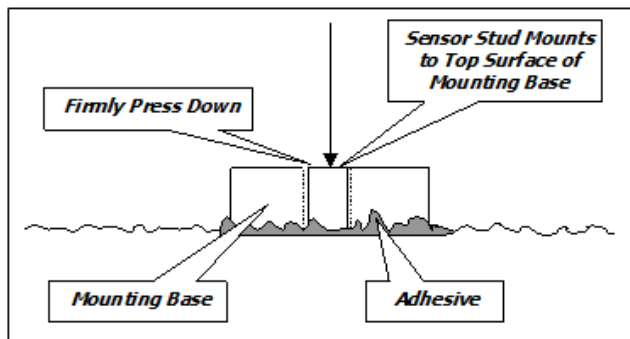

**Figure 5 – Adhesive Installation of Mounting Base**

### ***Magnetic Mount Procedure***

Magnetic mounting provides a convenient means for making portable measurements and is commonly used for machinery monitoring and other portable or trending applications.

---

Note: The correct magnet choice and an adequately prepared mounting surface are critical for obtaining reliable measurements, especially at high frequencies. Poor installations can cause as much as a 50% drop in the sensor frequency range.

---

Not every magnet is suitable for all applications. For example, rare earth magnets are commonly used because of their high strength. Flat magnets work well on smooth, flat surfaces, while dual-rail magnets are required for curved surfaces. In the case of non-magnetic or rough surfaces, it is recommended that the user first weld, epoxy or otherwise adhere a steel mounting pad to the test surface. This provides a smooth and repeatable location for mounting.

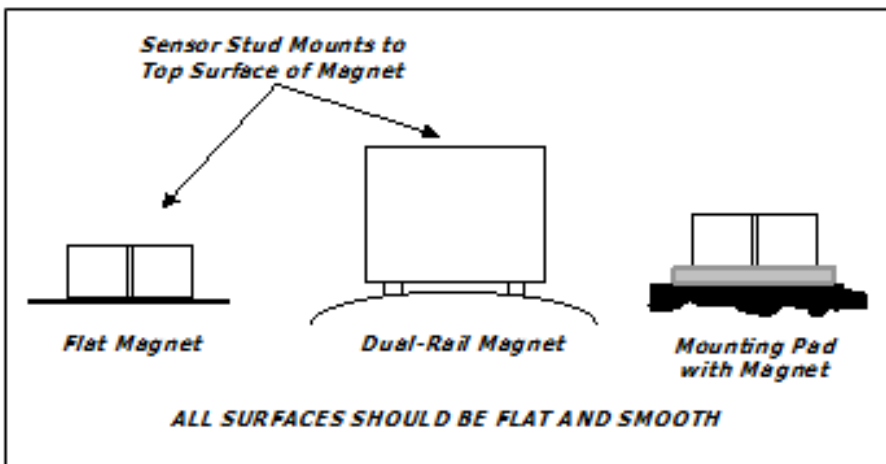

**Figure 6 – Magnet Types**

- Step 1: After choosing the correct magnet, inspect the unit to verify that the mounting surfaces are flat and smooth.
- Step 2: Stud-mount the accelerometer to the appropriate magnet according to the guidelines set forth in Steps 2 and 3 of the Standard Stud Mount Procedure.
- Step 3: Prepare a smooth, flat mounting surface. A minimum surface finish of 63  $\mu\text{in}$  [0.0016 mm] generally works best. After cleaning the surface and checking for burrs, wipe on a light film of silicone grease, machine oil or similar-type coupling fluid.
- Step 4: Mount the magnet/sensor assembly to the prepared test surface by gently “rocking” or “sliding” it into place.

---

Note: Magnetically mounting accelerometers carelessly has the potential to generate very high (and very damaging) g levels. To prevent damage, install the assembly gently. If unsure, please contact the factory for assistance.

---

## Wiring

On the following pages are eleven different wiring scenarios for the Smart Switch. The wiring legend below is applicable to all wiring diagrams.

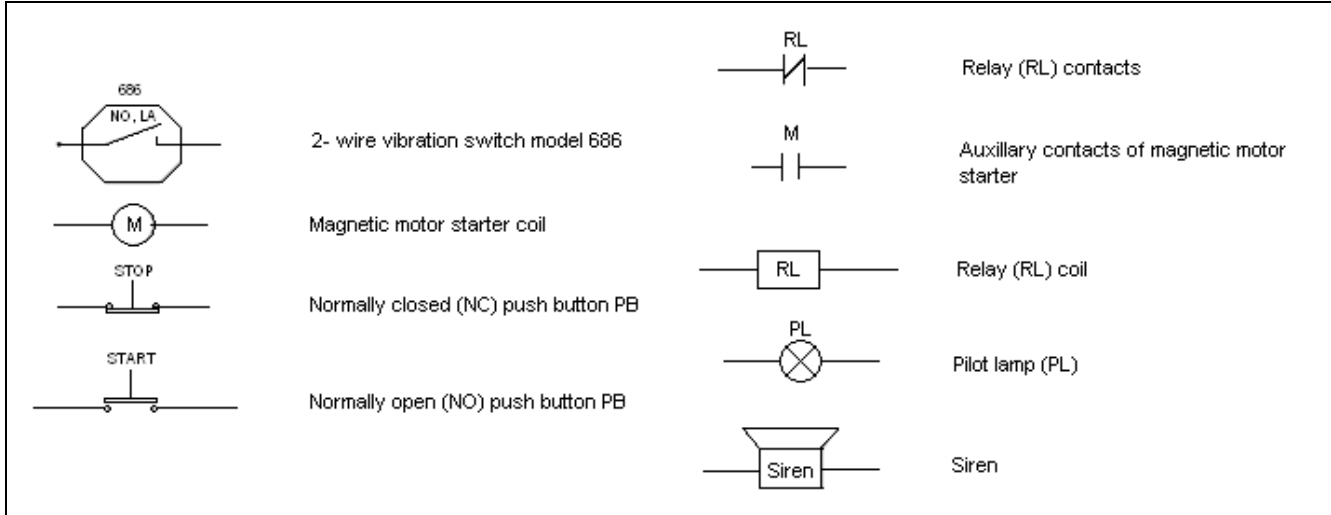
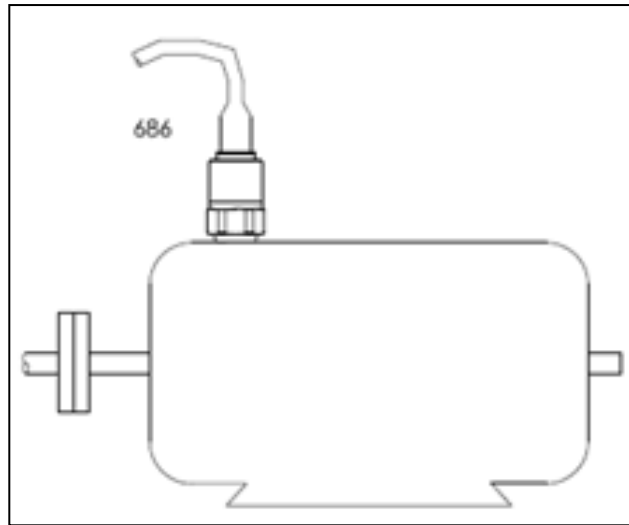
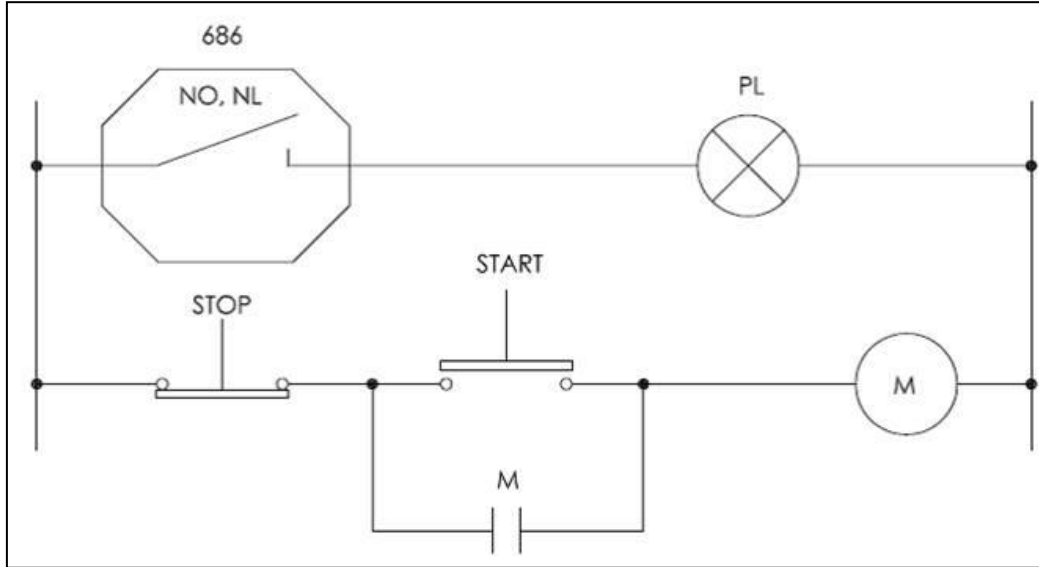

**Figure 7 – Wiring Diagrams Legend**

For those wiring scenarios that suggest the use of an external electromechanical relay, IMI suggests Omron general purpose relays as listed below. Visit [www.omron.com](http://www.omron.com) for more information.

Attribute	Omron Model Number				
	MJN2C-AC120	MJN2C-AC240	MJN2C-DC12	MJN2C-DC24	MJN2C-DC110
Contact Form	2 Form C (DPDT)				
Relay Rated Resistive Load	10 A @ 240 VAC/28 VDC				
Service Life- Electrical (Min @Rated Loads)	100,000 operations "average"				
Relay Max Resistive Switching Capacity	2400 VA, 280 W	240 VAC	12 VDC	24 VDC	110 VDC
Coil Nominal Voltage	120 VAC		1.2 W		
Coil Power Consumption	1.7 VA				
Coil Type	Non-Latching				
Seal Type	Unsealed				
Termination Style	Socket Mount				
Operating Temperature Range	-45 to +60 C with no icing or condensation		-45 to +70 C with no icing or condensation		
Dielectric Strength (AC for 1 min)	2500 VAC				
Approved Standards	UL, CSA				

*Indicating a High Level of Vibration in a Motor*



**Figures 8 and 9 – Indicating a High Level of Vibration in a Motor**

Pushing the Start pushbutton closes the M contacts and starts the motor. If the start-up delay option for the switch is enabled, the Smart Switch will not trip regardless of the vibration level during the specified delay time. After this delay, the vibration switch will be activated. If the vibration level exceeds the alarm threshold for a time period greater than the specified operational delay time, the relay will trip. This action will close the contact to the pilot lamp.

Since the NL (non-latching) option is specified, the pilot lamp will illuminate only while alarm threshold is exceeded. Should the vibration level drop below the alarm threshold value (based also on the specified hysteresis), the pilot lamp will turn off.

**Indicating High Levels of Vibration Simultaneously in Series (Such as Fan & Motor)**

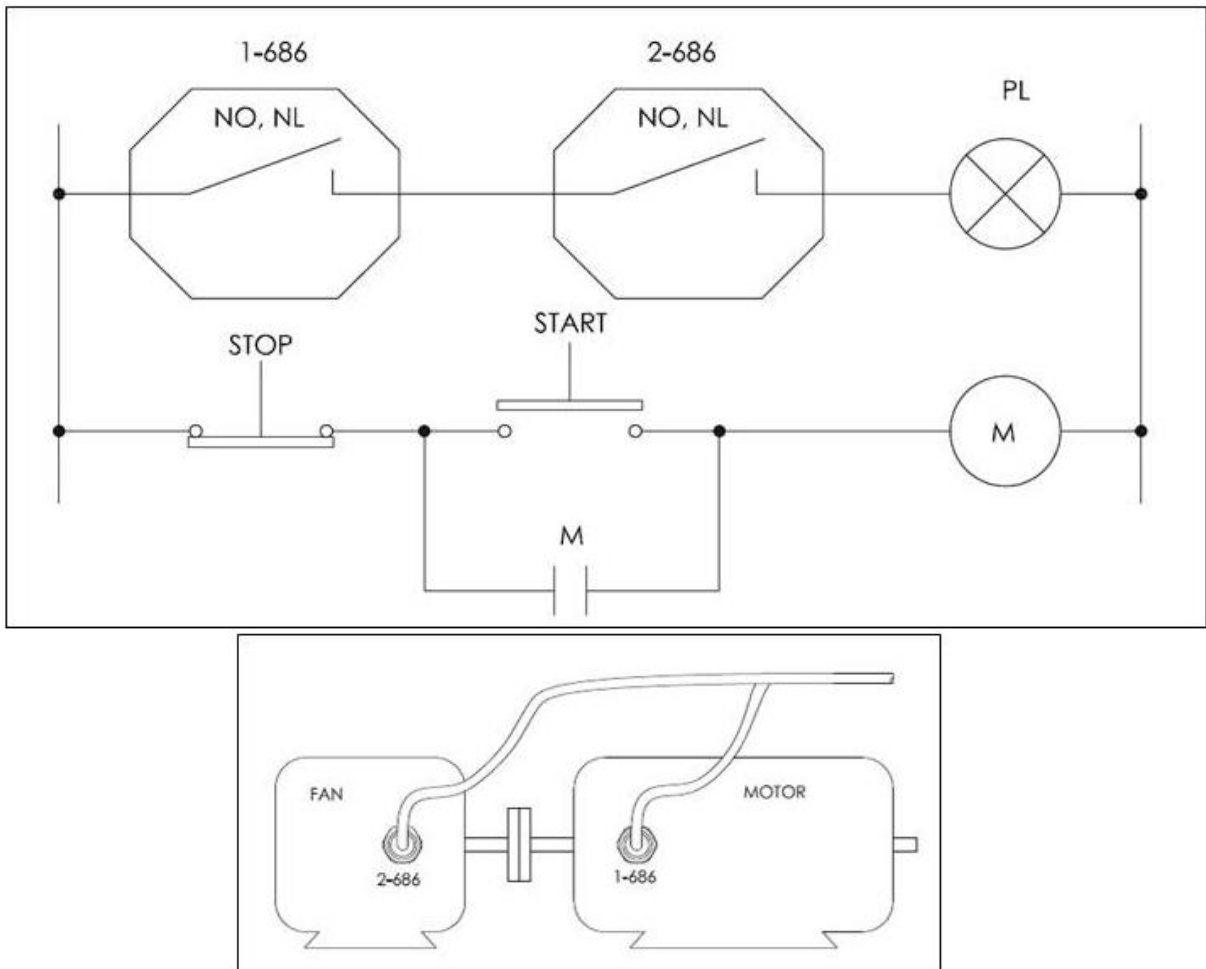

**Figures 10 and 11 – Indicating High Levels of Vibration Simultaneously in Series (Such as Fan & Motor)**

The Smart Switches are hooked up in series and installed on the two most loaded bearings across the coupling in the horizontal direction. Pushing the Start pushbutton closes the M contacts and starts the motor and fan. If the start-up delay option for the switches is enabled, the Smart Switches will not trip during the specified startup delay time, regardless of the vibration level. After this delay, the switch relays will be activated if the vibration level on both machines exceeds the alarm threshold for a period greater than the specified operation delay time. This action will close the contact to the pilot lamp.

Since the NL (non-latching) option is specified, the pilot lamp will illuminate only while set threshold on both machines is exceeded. Should the vibration level for one or both of the machines drop below the threshold value (based also on the specified hysteresis), the pilot lamp will turn off.



**Constant Siren Alarming in the Event of High Vibration Levels**

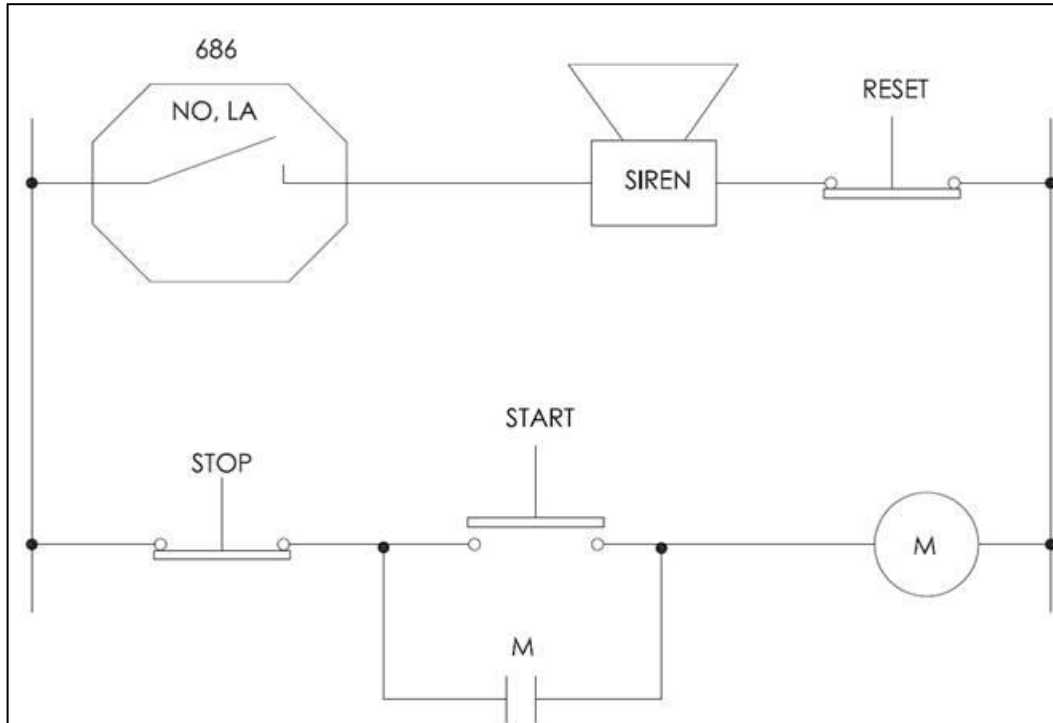
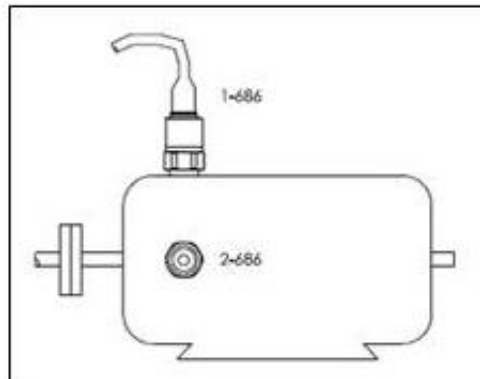
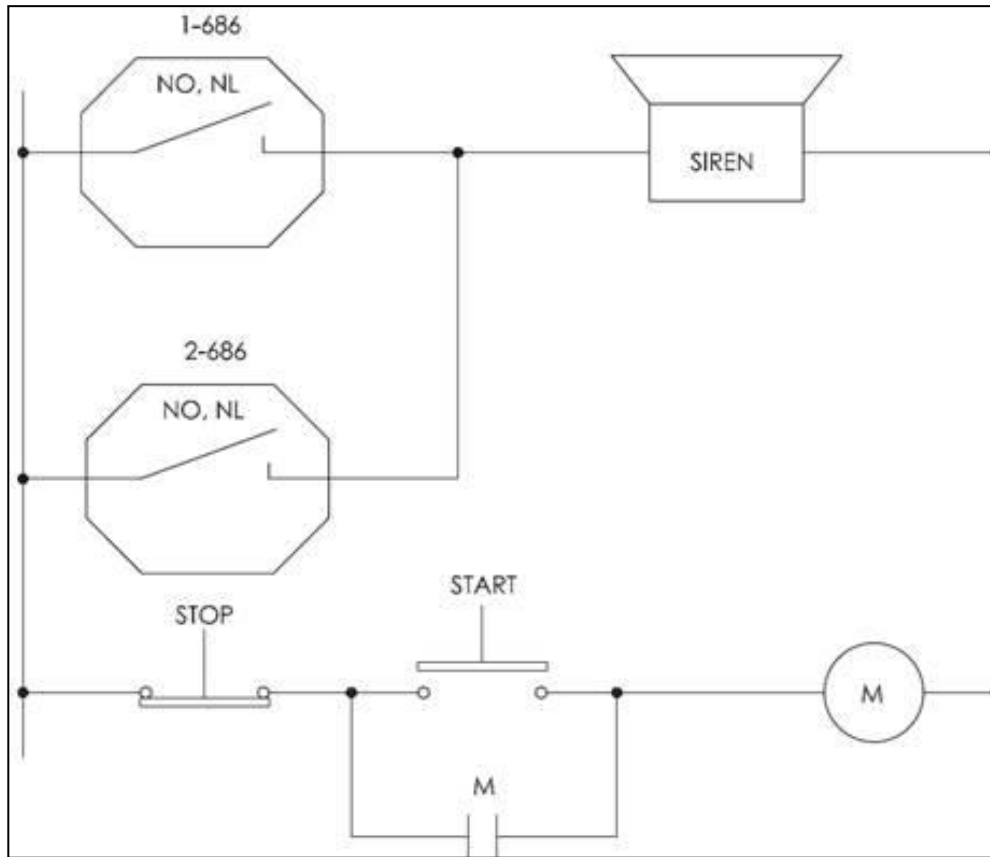

**Figure 12 – Constant Siren Alarming in the Event of High Vibration Levels**

The Smart Switch is hooked up for automatic constant siren alarming when the alarm threshold level is exceeded. Pushing the Start pushbutton closes the M contact and starts the motor. If the start-up delay option for the switches is enabled, the Smart Switches will not trip during the specified startup delay time, regardless of the vibration level. After this delay, the switch relay will be activated if the vibration level exceeds the alarm threshold for a period greater than the specified operational delay time. This action will close the contact to the alarm siren and activate it.

Since the LA (latching) option is specified, the alarm siren will be constantly energized after this high vibration event, even if the vibration level should drop below the alarm threshold. The Reset pushbutton should be engaged to de-energize the alarm siren and return the system to its original monitoring condition.

**Using Two Switches in Parallel to Monitor Two Axes Simultaneously on Same Motor**



**Figures 13 and 14 – Using Two Switches in Parallel to Monitor Two Axes Simultaneously on Same Motor**

The Smart Switches are hooked up in parallel and installed on the motor in horizontal and vertical directions. Pushing the Start pushbutton closes the M contact and starts the motor. If the start-up delay option for the switches is enabled, then during the specified startup delay time, the switches will not trip regardless of the vibration level. After this delay, the alarm siren will be activated if either of the switches experiences a vibration level over the alarm threshold lasting greater than the specified operation delay time.



Since the NL (non-latching) option is specified, the alarm siren will sound while alarm threshold on one or both switches is exceeded. Should the vibration level for both switches drop below the alarm threshold value (based also on the specified hysteresis), the alarm siren will turn off.

**Using Three Switches in Parallel to Monitor Three Motors Simultaneously**

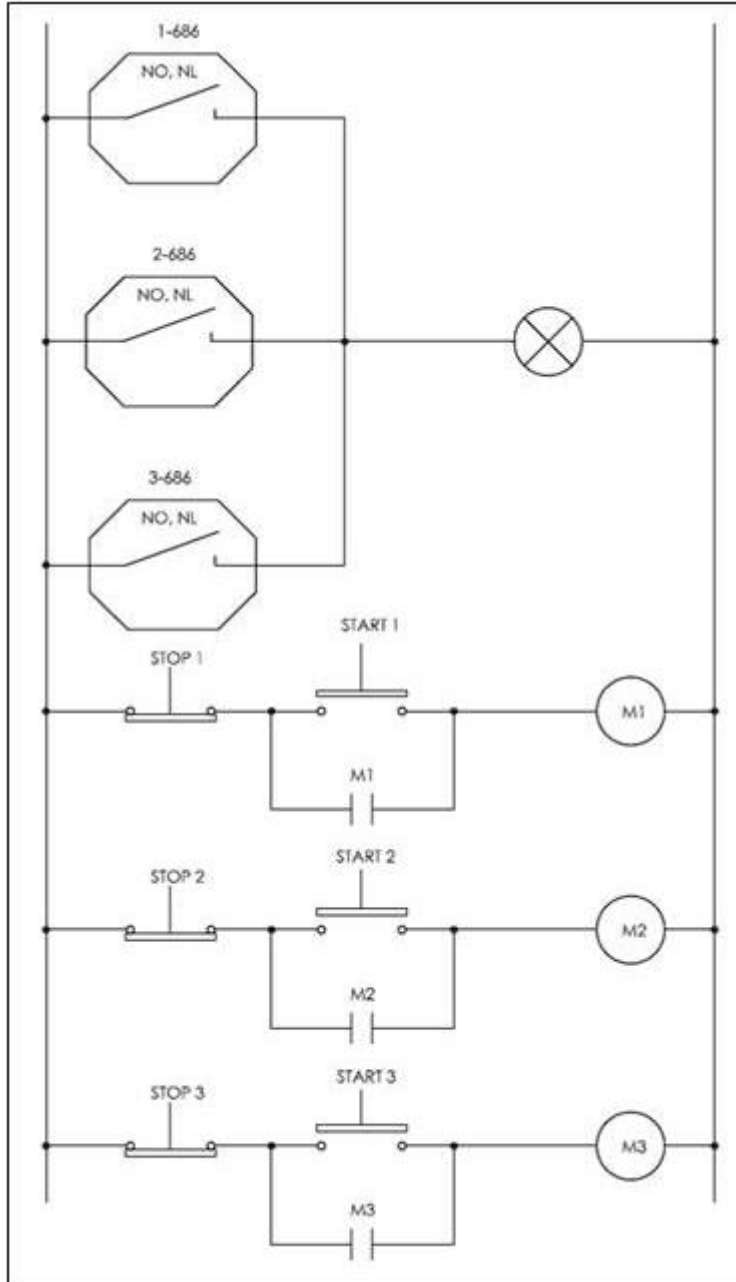

The three Smart Switches are hooked up in parallel and installed on each motor in the horizontal direction. This provides an economical solution for monitoring a group of machinery while only having to run one cable. Pushing any Start pushbutton will close the corresponding M contact and start the motor. If the start-up delay option for the switches is enabled, then during the specified startup delay time, the switches will not trip; regardless of the vibration level. After this delay, the pilot lamp will be illuminated if any of the switches experience a vibration level over the alarm threshold value lasting greater than the specified operational delay time.

Since the NL (non-latching) option is specified, the pilot lamp will illuminate while alarm threshold on any of the switches is exceeded. When the vibration level for all switches drops below their alarm threshold value (based also on the specified hysteresis), the pilot lamp will turn off.

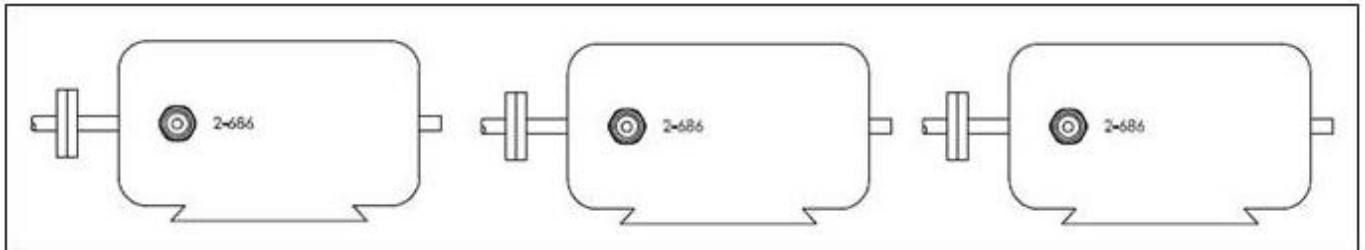

**Figures 15 and 16 – Using Three Switches in Parallel to Monitor Three Motors Simultaneously**

**Automatic Machinery Shutdown Using an External Electromechanical Relay**

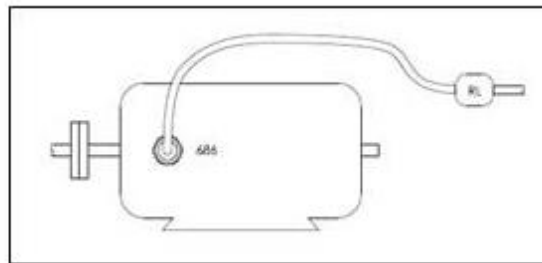
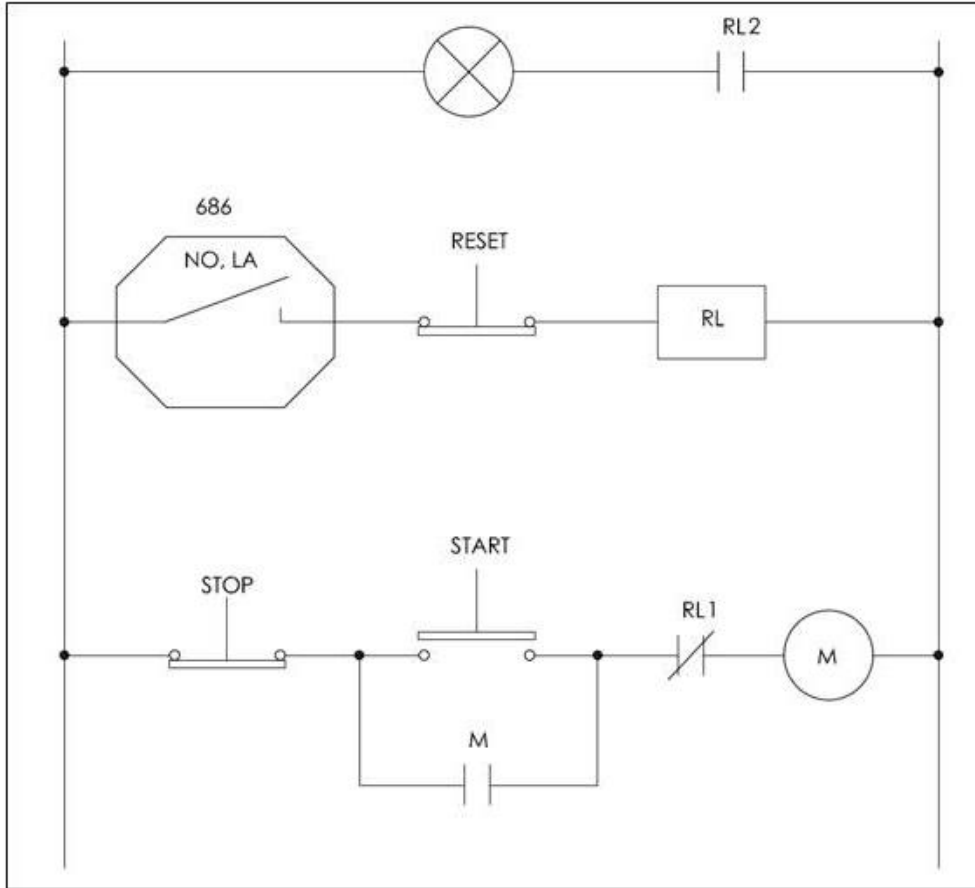

**Figures 17 and 18 – Automatic Machinery Shutdown Using an External Electromechanical Relay**

The Smart Switch is hooked up for automatic motor shutdown when the alarm threshold level is exceeded. The switch should be mounted in the horizontal direction on the bearing carrying the most load. Pushing the Start pushbutton closes the M contact and starts the motor. If the start-up delay option for the switches is enabled, the Smart Switches will not trip during the specified startup delay time, regardless of the vibration level. After this delay, the switch relay will be activated if the vibration level exceeds the alarm threshold for a period greater than the specified operational delay time. This action will close the contact and send a voltage to the RL relay coil. This will open the RL1 and close the RL2 contacts, shut down the motor, and light the pilot lamp.

Since the LA (latching) option is enabled, the RL coil will be constantly energized after this event; even if the vibration level drops below the alarm threshold value after shutdown. The Reset pushbutton should be pushed to reset the switch and close the RL1 and RL2 contacts before restarting the motor.

**Automatic Machinery Shutdown Using an External Electromechanical Relay While Monitoring 2 Axes**

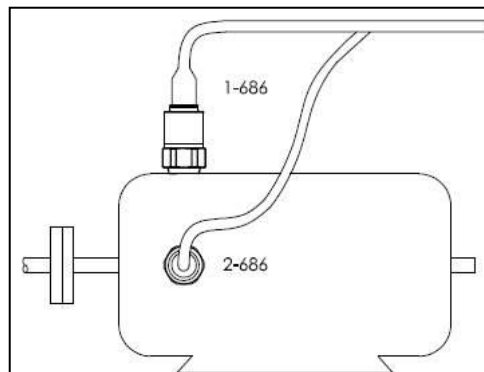
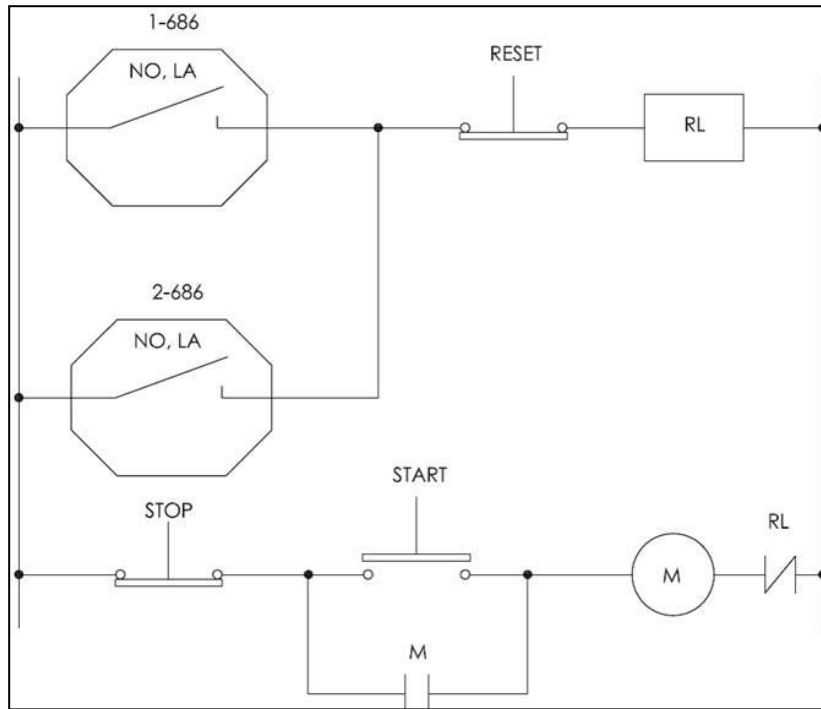

**Figures 19 and 20 – Automatic Machinery Shutdown Using an External Electromechanical Relay While Monitoring 2 Axes**

The Smart Switches are hooked up in parallel for automatic motor shutdown when the alarm threshold level is exceeded on either switch. The switches should be mounted in the horizontal and vertical direction at the bearing carrying the most load. Pushing the Start pushbutton closes the M contact and starts the motor. If the start-up delay option for the switches is enabled, the Smart Switches will not trip during the specified startup delay time, regardless of the vibration level. After this delay, the switch relay will be activated if the vibration level of either switch exceeds the alarm threshold for a period greater than the specified operational delay time. This action will close the contact and send a voltage to the RL relay coil. This will open the RL contacts and shut down the motor.

Since the LA (latching) option is specified, the RL coil will be constantly energized after this event; even if the vibration level drops below the alarm threshold value after shutdown. The Reset pushbutton should be pushed to reset the switch and close the RL contacts before restarting the motor.

Using the Switch and External Latching for Automatic Machinery Shutdown

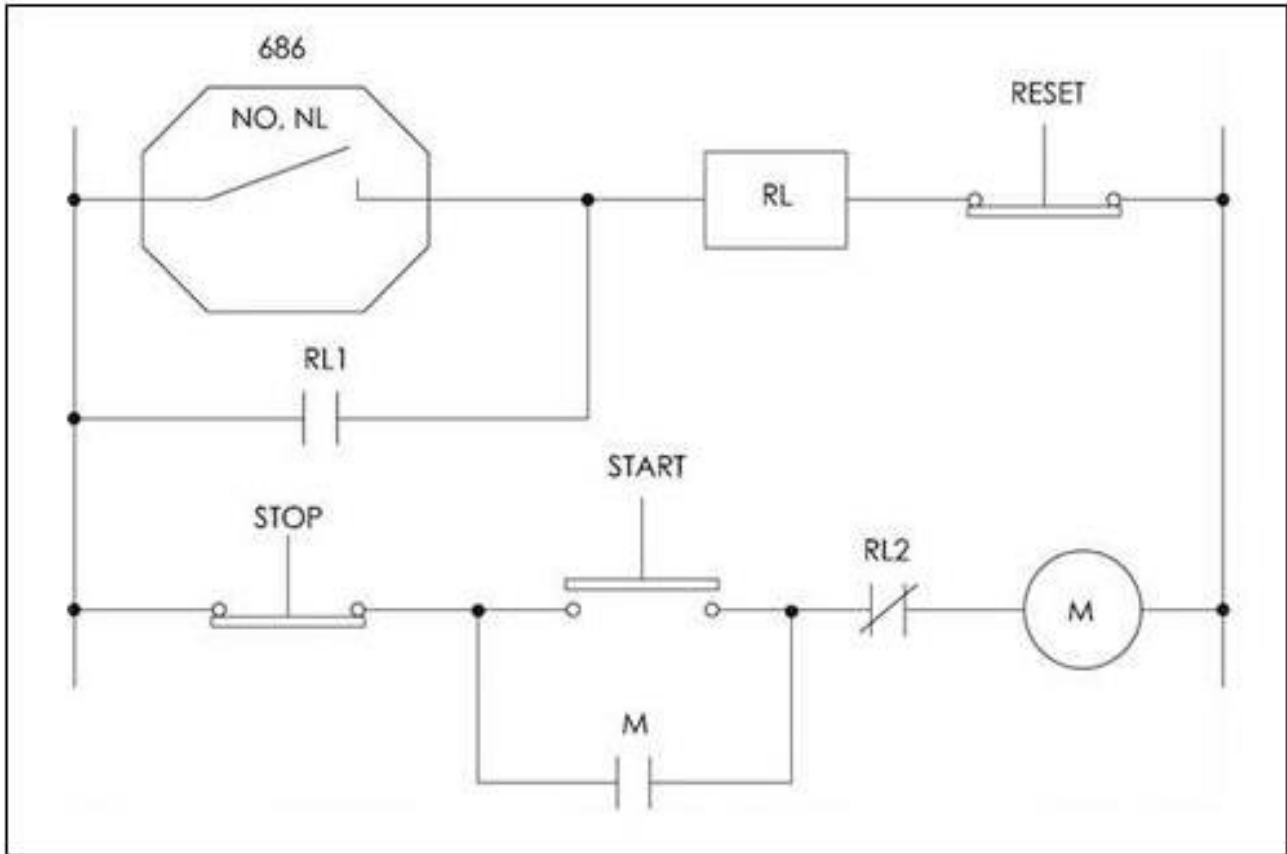
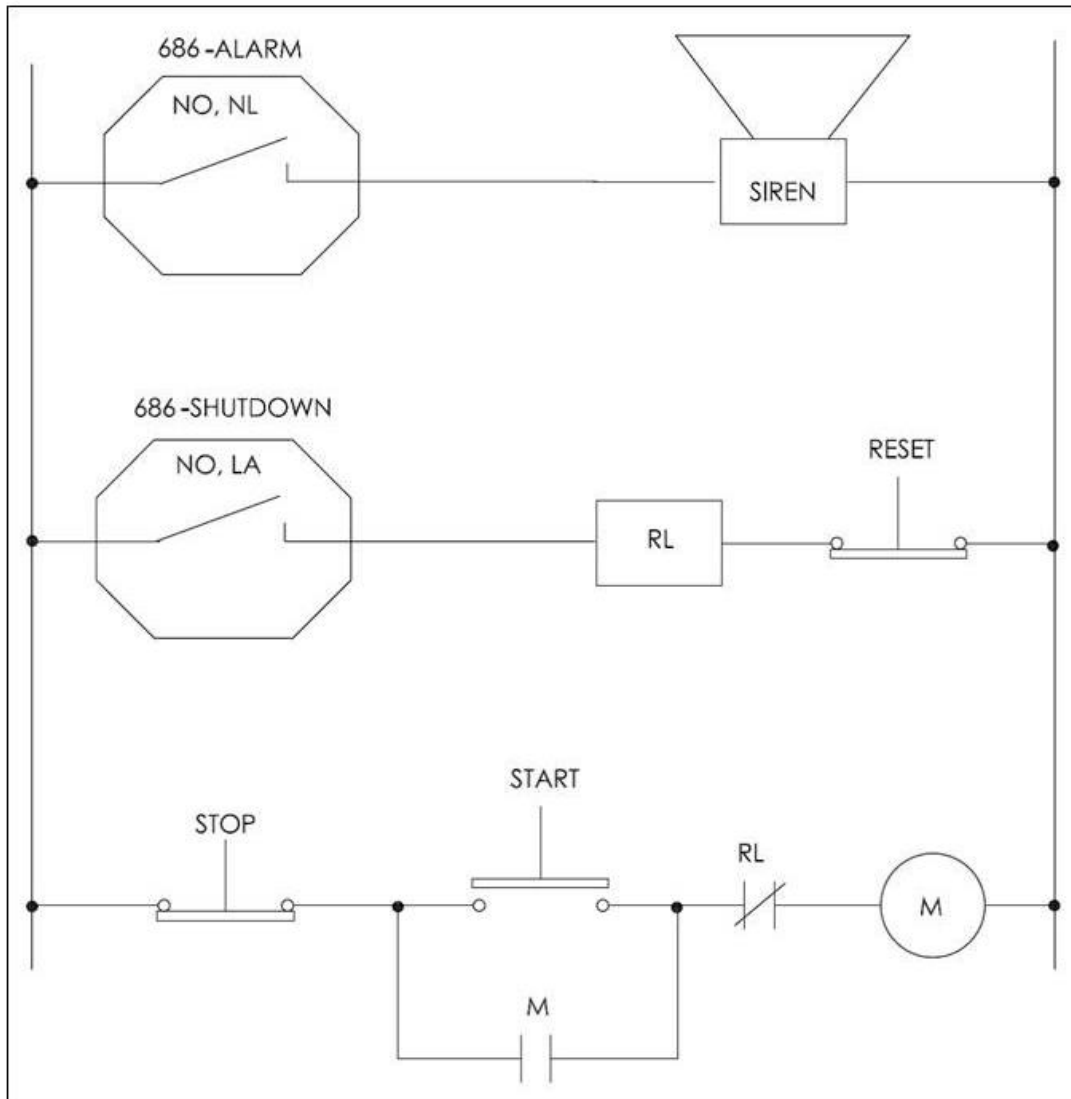

**Figure 21 – Using the Switch and External Latching for Automatic Machinery Shutdown**

The Smart Switches are hooked up for automatic motor shutdown in case of high vibration levels on critical machinery. Since RL2 contacts are normally closed, pushing the Start pushbutton closes the M contact and starts the motor. If the start-up delay option for the switches is enabled, the Smart Switches will not trip during the specified startup delay time, regardless of the vibration level. After this delay, the switch relay will be activated if the vibration level of either switch exceeds the alarm threshold for a period greater than the specified operational delay time. This action will close the contacts and send a voltage to the RL relay coil. This will open the RL2 contacts and shut down the motor.

Since the LA (latching) option is specified, the RL1 contacts are used for external latching. Closing of RL1 provides constant coil energizing after the shutdown event. Therefore, when the vibration level drops below the alarm threshold level after shutdown, the closed RL1 contacts still energize the RL coil and keep RL2 in the open position. The Reset pushbutton should be pushed to reset the 2-wire switch, close the RL2 contacts and open the RL1 contacts before restarting the motor.

**Both Alarm Siren and Automatic Machinery Shutdown Using Two Switches**

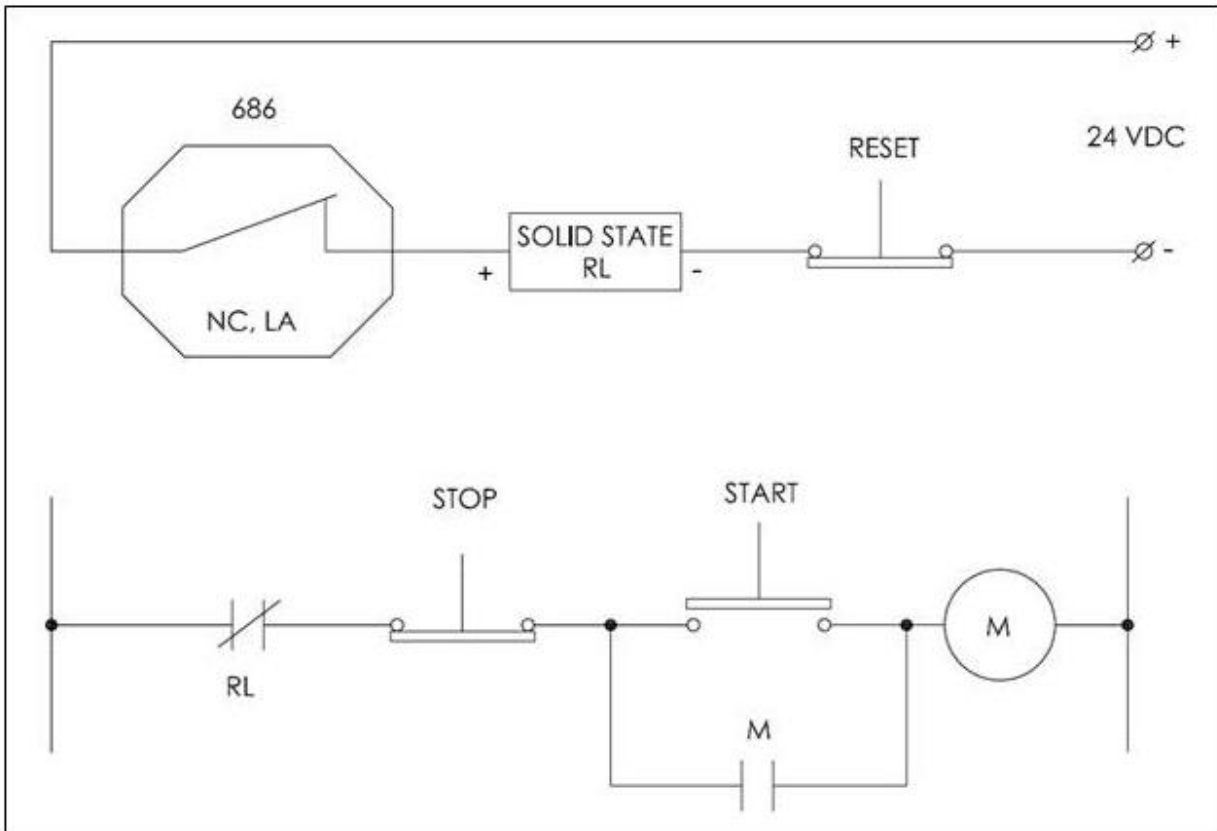

**Figure 22 – Both Alarm Siren and Automatic Machinery Shutdown Using Two Switches**

The Smart Switches are hooked up for providing alarm siren and automatic motor shutdown when the alarm threshold levels are exceeded. To accomplish this, the two switches have two different threshold values; one for alarm and one for shutdown. Pushing the Start pushbutton closes the M contact, and since RL2 contacts are normally closed, starts the motor. If the start-up delay option for the switch is enabled, the switch will not trip regardless of the vibration level during the specified delay time. After this delay, if the vibration level exceeds the alarm threshold for the alarm switch, it will be activated and apply a voltage to the alarm siren. Since the NL (non-latching) option is specified for this switch, the alarm siren will be energized until the vibration level falls below the alarm threshold value (based also on the specified hysteresis). If the vibration level exceeds the shutdown alarm threshold, the second vibration switch will be activated and apply a voltage to the RL relay coil. This will open the RL contacts and shut down the motor. Since the LA (latching) option is specified, the RL coil will be constantly energized after this event; even though the vibration level will drop below the alarm threshold value after shutdown. The Reset pushbutton should be pushed to reset the switch and close the RL contacts before restarting the motor.



*Automatic Machinery Shutdown Based on Normally Open Solid-State Relay*



**Figure 23 – Automatic Machinery Shutdown Based on Normally Open Solid-State Relay**

The Smart Switch is hooked up to provide automatic motor shutdown when the alarm threshold level is exceeded. Pushing the Start pushbutton closes the M contact, and since the switch is Normally Closed, the solid state relay will be energized and the RL contacts will be closed. This will start the motor. If the start-up delay option is enabled, the switch will not trip regardless of the vibration level during the specified delay time. After this delay, if the vibration level exceeds the alarm threshold, it will be activated, thereby opening its contacts and de-energizing the solid state relay input. This will open the RL contacts and shut down the motor. Since the LA (latching) option is specified, the solid state relay input will be constantly de-energized after this event even if the vibration level drops below the alarm threshold value after shutdown. The Reset pushbutton should be pushed to reset the switch and close the RL contacts before restarting the motor.

**Automatic Machinery Shutdown of Three-Phase Electrical Motor Based on a N.O. Solid State Relay**

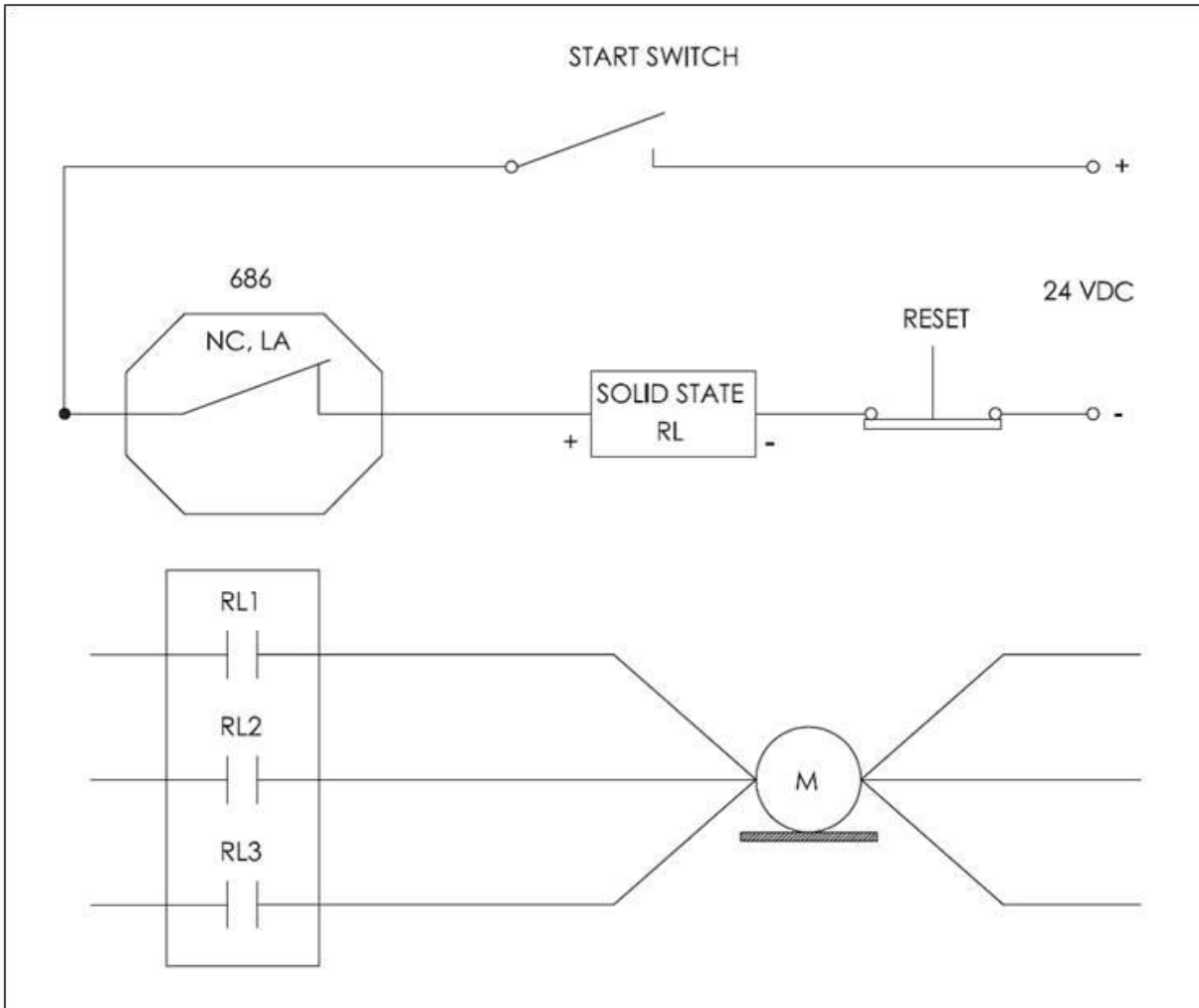

**Figure 24 – Automatic Machinery Shutdown of 3-Phase Electrical Motor Based on a N.O. Solid State Relay**

The Smart Switch is hooked up to provide automatic motor shutdown when the alarm threshold level is exceeded using a normally open three channel solid state relay. Since the Smart Switch is normally closed, closing the Start Switch will energize the solid state relay. This will cause the RL1, RL2, and RL3 contacts to close and start the motor. If the start-up delay option for the switch is enabled, the switch will not trip regardless of the vibration level during the specified delay time. After this delay, if the vibration level exceeds the alarm threshold, it will be activated, thereby opening its contacts and de-energizing the solid state relay input. This will open the RL1, RL2, & RL3 contacts and shut down the motor. Since the LA (latching) option is specified, the solid state relay input will be constantly de-energized after this event; even if the vibration level drops below the alarm threshold value after shutdown. The Reset pushbutton should be pushed to reset the switch and close the RL1, RL2, & RL3 contacts before restarting the motor. This will start the motor immediately without using the Start pushbutton.

**Programming Software**

The Smart Switch can be user-programmed with the optional Model 600A29 Programming Kit. The kit includes USB programmer cable/dongle (Model 070A100), software (Model EE225), terminal block/integral cable adapter (Model 042M17) and magnet clip (Model 080A214). The software can also be downloaded from IMI's website, [www.pcb.com](http://www.pcb.com). This software must be installed prior to connecting the Smart Switch to the computer using the USB programmer cable. The software includes both the drivers and user interface needed for programming the Smart Switch. During initial installation, you may need administrative rights for the computer in order to install the drivers. Once installed, administrative rights are not required for use.



**Figure 25 – Model 600A29 USB Programmer Kit**

**Program Installation**

Installing the Software and USB Driver: Insert the software CD provided into the CD drive. The software will start the installation automatically if your PC is set to auto-install applications. If not, browse the CD and click on Setup.exe to start the installation process. The default installation directory is C:\PCB\EE225. It is recommended to use the default setting.

The installer will first install the software and then the WinUSB device driver. This device driver is required for the programmer software to communicate with the 070A100 USB programmer cable included in the programmer kit.

The following screens will be displayed when the installer starts. Click the Next button to proceed from step to step.

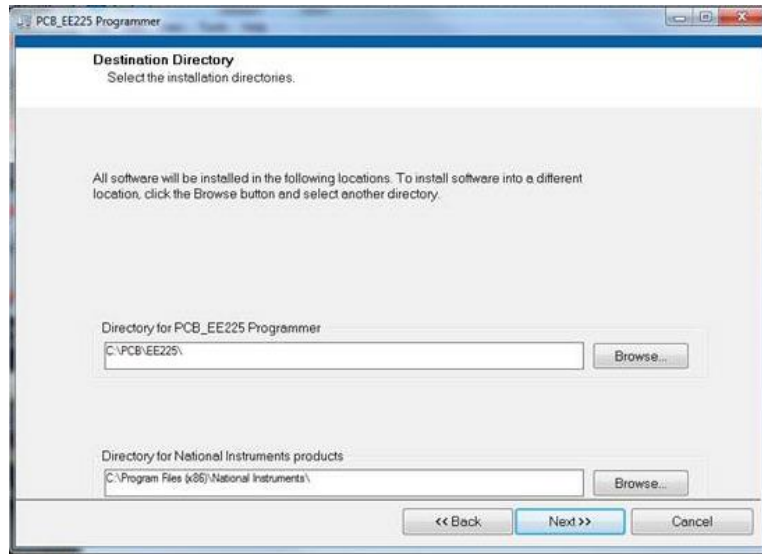

**Figure 26 – Install Location Screen**

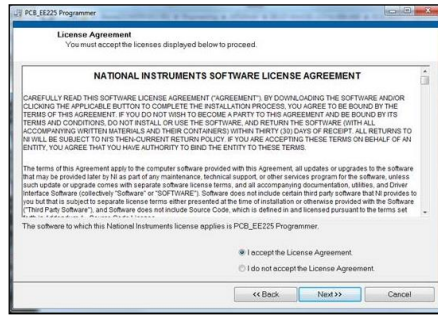

**Figure 27 – National Instruments Software License Agreement**

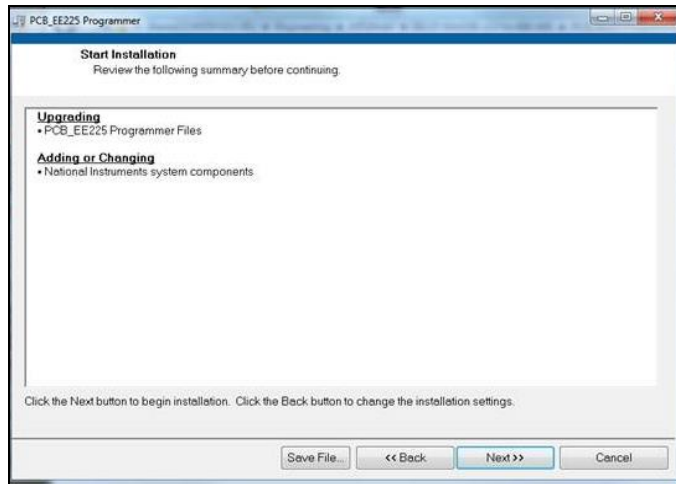

**Figure 28 – Installation Verification Screen**

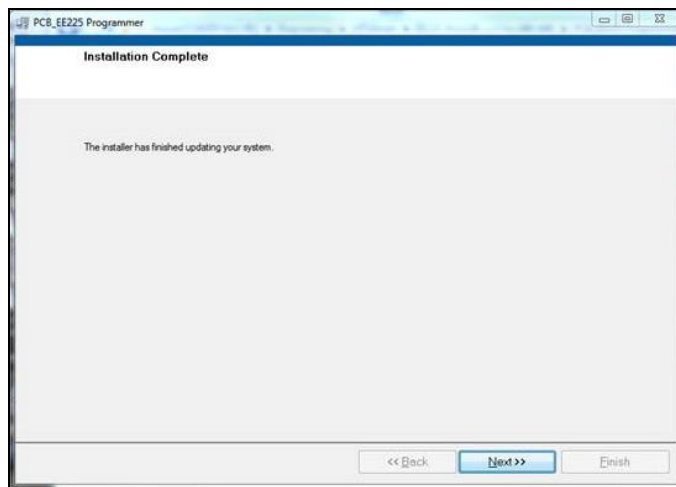

**Figure 29 – Installation Complete Screen**

After the software completes, the USB driver installer will start automatically. The initial USB installer will look similar to the one below.



Figure 30 – WinUSB Driver Installation Screen

The drivers will now be properly installed and you should get the following screen. Click “Finish”. The software is now ready to use.

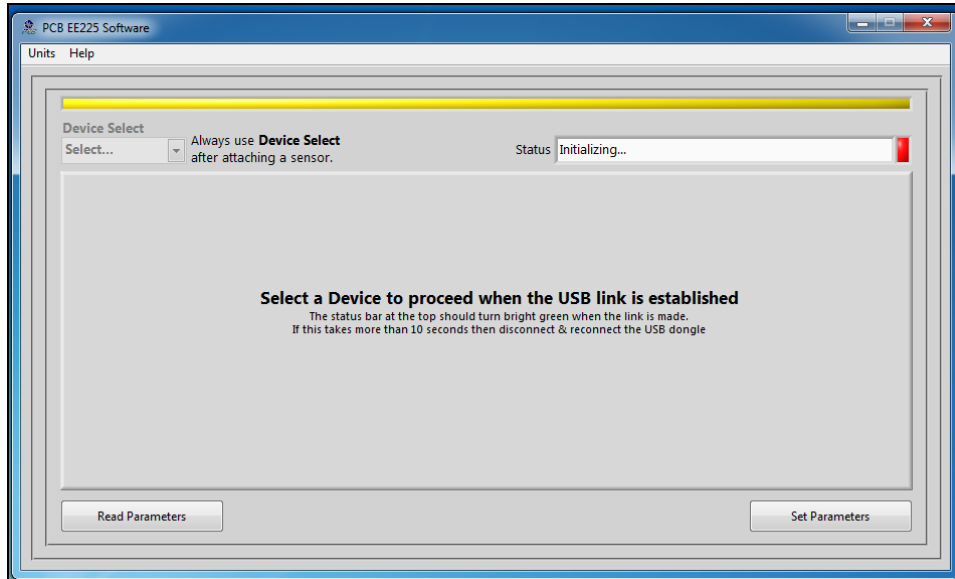

Figure 31 – WinUSB Driver Installation Complete Screen

**Running the Software**

Connect the USB programmer cable to the Smart Switch. Hold a magnet to the indicated MAVT™ point on the Smart Switch. Wait about 2 seconds. While keeping the magnet against the Smart Switch, connect the USB programmer cable to a USB port on the PC. Run the software from the Start | All Programs | PCB EE225 Software menu item.

Initially the screen will appear as in **Error! Reference source not found.** with a yellow bar and status indicating ‘Initializing...’ followed by the message: “Connecting to USB Dongle...”.



**Figure 32 – Software While Connecting to USB Programmer Cable**

Once the connection is made the bar at the top of the screen will turn green and the status will indicate “USB Connection Success - Select a device”. If the software and USB programmer cable fail to connect, remove and reinsert the USB programmer cable.

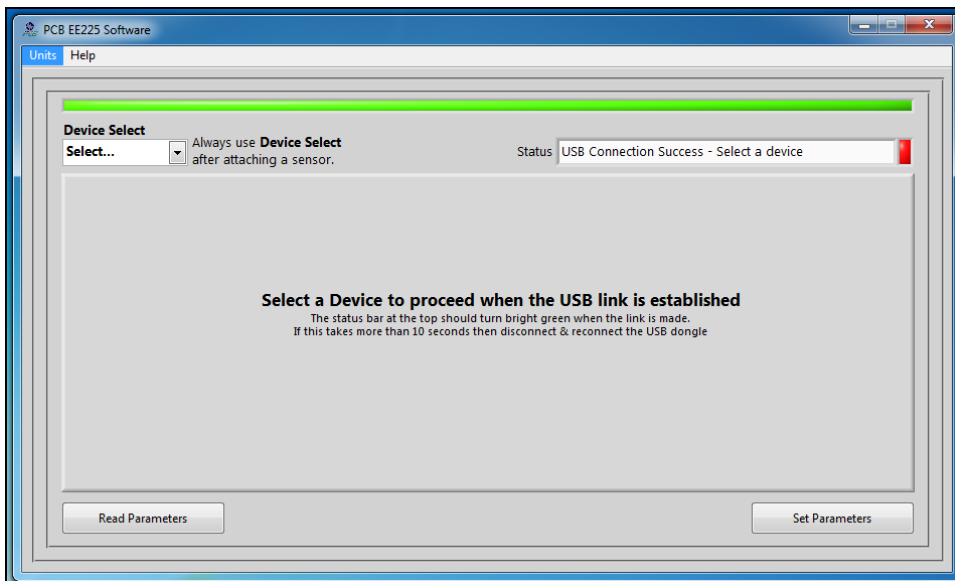

**Figure 33 – Software After Connecting to USB Programmer Cable**

To select a device, click on the Device Select pull down menu and select the device you'd like to program. In this case, select 686.

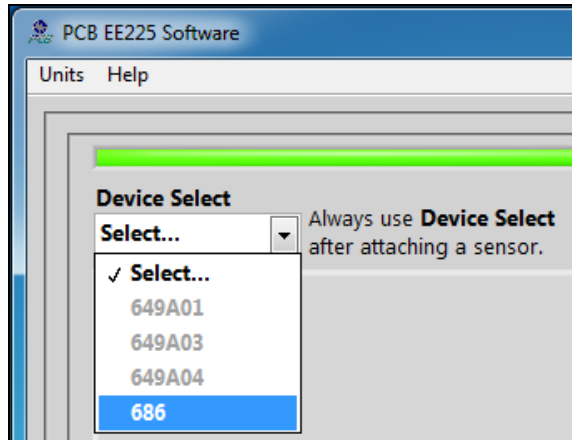

**Figure 34 – Device Selection**

Once a product is selected, the software will prompt you to confirm connection of the sensor to the PC using the USB programmer cable. Click OK to proceed.

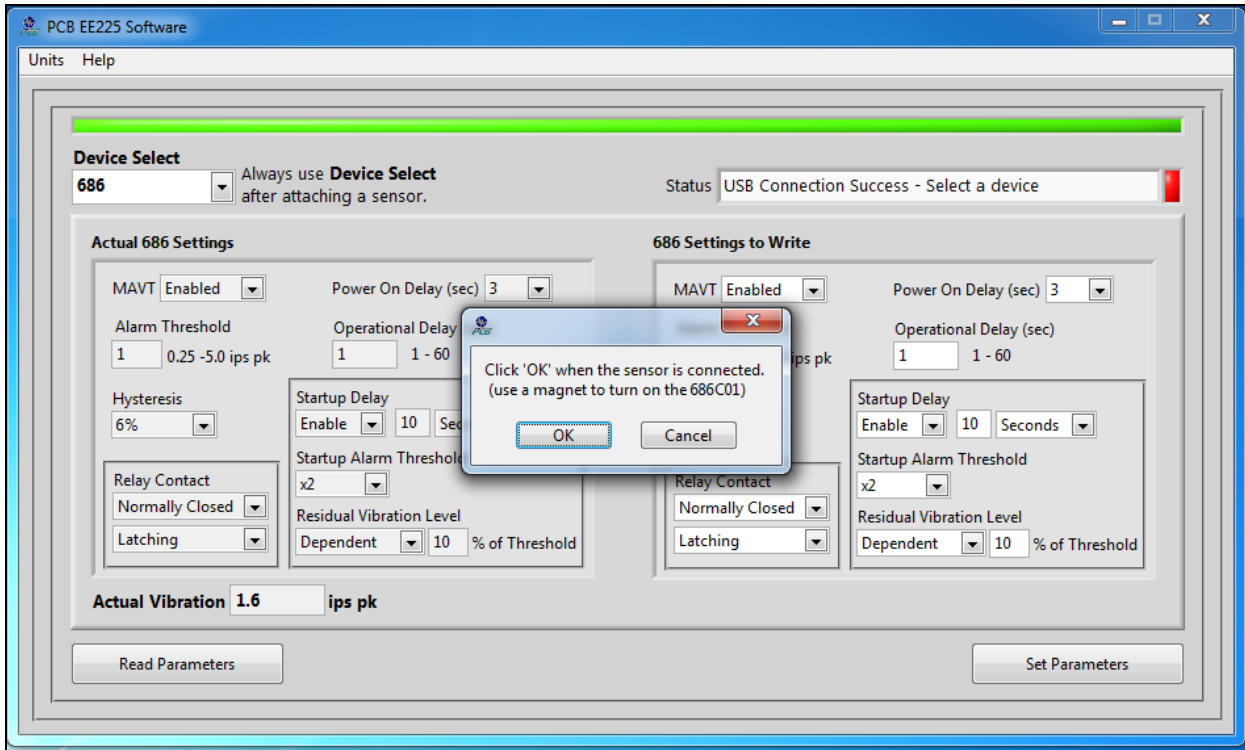

**Figure 35 – Sensor Connection Screen**

While the software is establishing communication with the sensor, the status will display 'Checking Status...' and the colored indicator box next to the status will alternate between red and yellow. This will take approximately 15 seconds. Once communication is established, the indicator box will turn green and the software will read the sensor's current settings and data. The fields presented in the main body of the screen will be specific to the selected sensor.

## Programming Sections

The screen has two sections:

- Actual 686 Settings – This section shows the settings currently programmed in the sensor.
- 686 Settings to Write – This section shows the options for programming the sensor.

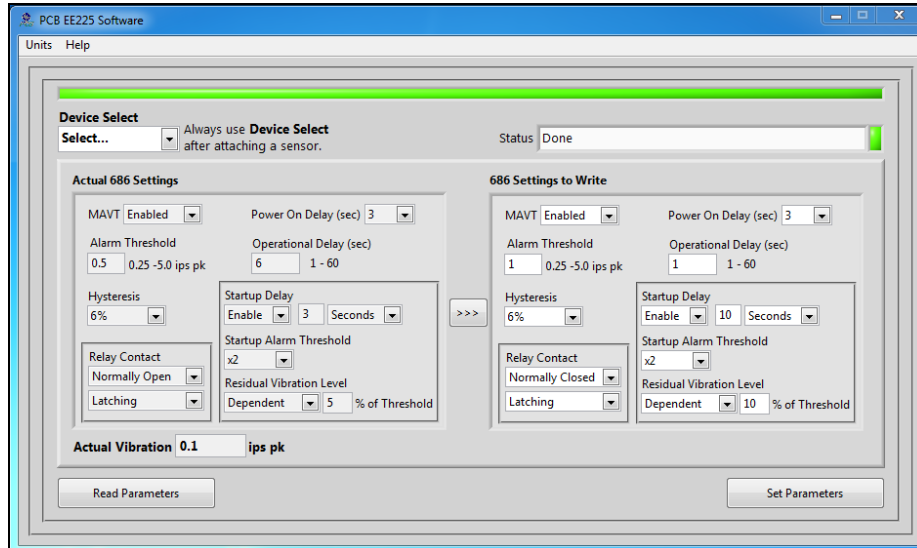

Figure 36 – Typical Smart Switch Screen After Successful Parameter Read

## Reading and Writing Parameters

- Reading Parameters - To read the current sensor settings, click the Read Parameters button. This operation takes approximately 45 seconds to complete.
- Transferring Actual Settings to Settings to Write Field - Use the '>>>' button to transfer all Actual Settings to the Settings to Write fields.
- Writing Parameters- Select the appropriate mode and enter any pertinent parameter information. Click the Set Parameters button. This causes the settings to be sent to the sensor and then read back and displayed in the Actual 686 Settings.

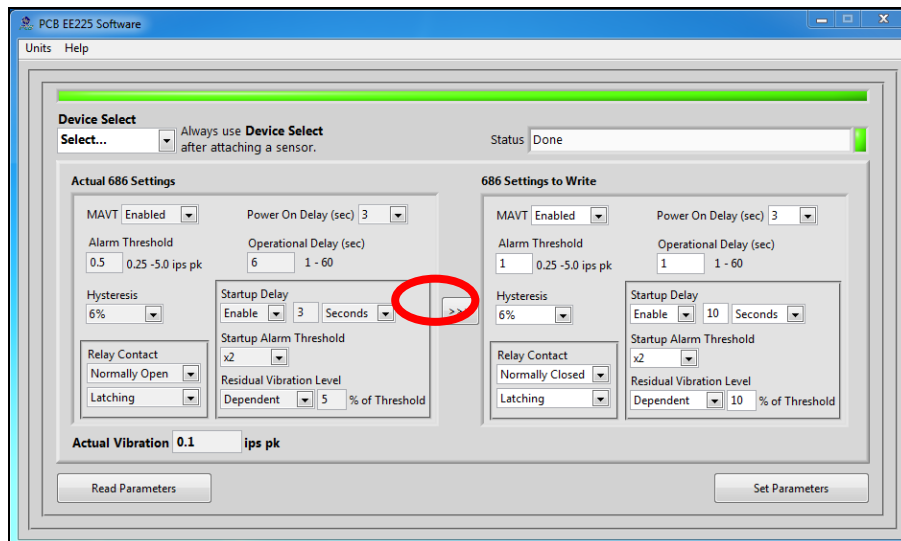

Figure 37 – Transferring Actual Settings to Settings to Write Field



## Parameter Options

The software presents one read-only parameter (Actual Vibration) and several parameters that can be programmed to optimize performance of the Smart Switch. At any point during the programming process, the values can be changed between imperial and metric measurements by clicking the Units dropdown in the top navigation menu and then selecting the appropriate measurement type.

Parameter	Description	Acceptable Value(s)
Actual Vibration	Actual vibration (ips pk) being sensed by the switch at time when Read Parameters button is clicked.	N/A
MAVT™	Capability to determine and set the alarm threshold value automatically by the Smart Switch based on the actual vibration level measured by it. For more information about the MAVT™ feature, see page 16.	Enabled Disabled
Alarm Threshold	Vibration level at which the relay will change state.	0.25- 5.0 ips pk 6.35-127 mm/s pk
Hysteresis	Percentage that actual vibration must fall below the alarm threshold in order for a non-latching relay to automatically reset itself. Hysteresis prevents a relay from continually changing states when the vibration level is hovering around the alarm threshold level.	3% 6% 10%
Relay Contacts- Normal State	State in which the relay stays when not tripped.	Normally Open Normally Closed
Relay Contacts- Reset State	How the relay operates once actual vibration falls below the alarm threshold. <ul style="list-style-type: none"> <li>Latching: Relay to latch or stay in the alarm state until manually reset regardless of the vibration level.</li> <li>Non-Latching Relay automatically resets once the vibration level falls below the alarm threshold (hysteresis) level.</li> </ul>	Latching Non-Latching
Power On Delay	Specified time period immediately after power is applied to the switch during which the relay will not trip regardless of the vibration level. Prevents a relay trip during high transient vibration levels that may occur during a normal machine startup.	3 sec 20 sec
Operation Delay	Specified time period for which actual vibration must constantly exceed the Alarm Threshold before the relay changes state. Prevents a relay trip as a result of a short transient spike in vibration level that may not even be caused by a machine fault.	1-60 sec
Startup Delay- Status	Specified time period immediately after power is applied to the equipment being monitored during which the relay will not trip regardless of vibration level.	Enabled Disabled
Startup Delay- Time Period	Time period during which vibration is ignored.	1-60 sec 1-30 min
Startup Delay- Startup Alarm Threshold	Maximum vibration ignored during the time period. Calculated as a multiple of the Alarm Threshold.	2x 4x 8x Blocked (All vibration)
Startup Delay- Residual Vibration Level	Minimum vibration level that, once surpassed at equipment startup, triggers the countdown of the Startup Delay Time Period.	Dependent (Threshold %) Independent (Value)  Max 40% of Threshold

Unless otherwise specified, the Smart Switch comes from the factory with a set of default parameters. The specific set of parameters depends on the last alphanumeric character in the model number.

		Last Alphanumeric Character				
		1	2	3	4	X
Parameter	MAVT™	Enabled				Custom, Customer- Specific Configuration
	Alarm Threshold	0.60 ips				
	Hysteresis	6%				
	Relay Contacts- Normal State	Normally Open	Normally Closed	Normally Open	Normally Closed	
	Relay Contacts- Reset State	Latching	Latching	Non-Latching	Non-Latching	
	Power On Delay	3 sec				
	Operation Delay	6 sec				
	Startup Delay- Status	Enabled				
	Startup Delay- Time Period	3 sec				
	Startup Delay- Startup Alarm Threshold	2x				
	Startup Delay- Residual Vibration Level	Dependent 5% of Threshold				

### Execution of Delays

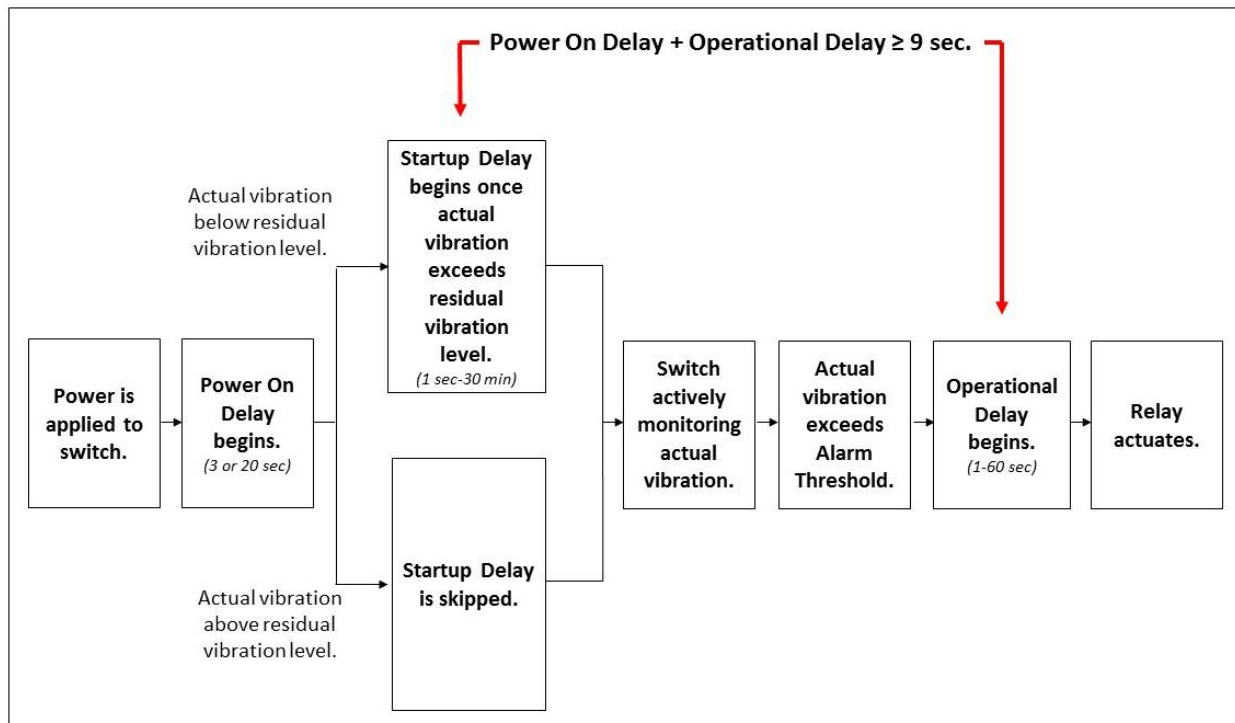

***Magnetically Adjustable Vibration Threshold (MAVT™)***

Magnetically Adjustable Vibration Threshold (MAVT™) is a Smart Switch selectable feature via USB programming. This unique capability allows the alarm threshold value to be determined and set automatically by the Smart Switch based on the actual vibration level being measured by it. This convenient feature permits any machine to be protected by a vibration switch within seconds without knowing anything about its vibration levels.

The Smart Switch has no accessible mechanical adjustments (ie. screw pots or DIP switches) that are found on other style electronic vibration switches. However, when the MAVT™ option is selected, the hermetically-sealed switch becomes adjustable through magnetic actuation. By touching a specified location on the housing with a strong permanent magnet for 2 seconds, an internal microprocessor is actuated that initiates the test sequence.

Note: The magnet clip (Model 080A214) is a supplied accessory when the Smart Switch is ordered from the factory with the optional 600A29 USB Switch Programmer Kit.



**Figure 38 – Magnet Clip**

***MAVT™ Procedure***

Be absolutely sure you do not have the switch connected to the machine's trip circuit during this procedure as the trip relay is activated several times during the procedure and will cause the machine to shut down and turn on several times. This could cause damage to your machinery.

1. Mount the Smart Switch on the machine that the switch will monitor. Be sure that the machine is operating in a steady state condition. If it is not operating, turn the machine on and allow enough time for the vibration level to normalize before going to the next step.
2. Connect the switch to the power supply using an appropriate cable. Since the Smart Switch operates off universal power, any power supply that outputs 24-240 VDC or 24-240 VAC, 50/60 Hz will work. A simple 24V power supply/signal conditioner (Model 480C02) will also work well and has the added advantage of visually indicating when the calibration process has been completed via its built-in meter. Allow 30 seconds for the switch to power up.
3. Touch the permanent magnet to the target on the side of the switch for approximately 2 seconds to initiate the process.
4. The alarm threshold calibration process takes approximately 30 seconds. (The amount of time needed varies based on the difference between the previous and new alarm threshold values.) During this process, the unit will measure the average vibration amplitude, set the alarm threshold value to two times this average value and store this value in a non-volatile memory. The relay contacts open and close repeatedly during this process.
5. Disconnect the Smart Switch from the power supply.
6. The switch can now be permanently installed on the machine for protection.

## Switch Model Number Template

### Prefix Option

- Blank** No Prefix Option
- EX** CSA Approval
- M** Metric Stud (Not w/ Terminal Block)
- EXM** Metric Stud, CSA Approval (Not w/ Terminal Block)

### Version

- B** B Version (All models except those listed for C version)
- C** C Version (Models 686C01 & 686C0X only)

### Electrical Connection

- 0** 2-Pin Mil-C-5015 Connector
- 1** Integral Cable
- 6** Integral Armored Cable
- 7** Terminal Block

### Program Configuration

- 1 1 0 060 1 06 0 0 1 0 03 0 0 005  
 2 " " " " " 1 " " " " " " " "  
 3 " " " " " 2 " " " " " " " "  
 4 " " " " " 3 " " " " " " " "  
 X Custom Program Configuration (Fill out form below)

### Use for Integral Cable Models Only

#### Cable Length Units

- Blank** English (ft)
- M** Metric (m)

#### Cable Length

- 001 to 200** Cable Length in ft
- 001 to 060** Cable Length in m

#### Cable Termination

- AB** BNC Jack
- AC** BNC Plug
- AD** Pigtail
- BZ** Blunt Cut

#### Armor Length

- Blank** Same as Cable Length
- 001 to 050** Armor Length in ft
- 001 to 015** Armor Length in m

#### Suffix Option

- Blank** No Suffix Option
- D** ATEX/IECEx Ex d Approval (EX prefix must also be selected)

## Custom Program Configuration

### MAVT™

A

0	Disabled
1	Enabled

### Alarm Threshold

B

0	English
1	Metric

C Value = 0.25 to 5.00 ips pk  
04.5 to 90.0 mm/sec pk

e.g.: 0.25 ips = 

0	2	5
---	---	---

  
25.4 mm/sec = 

2	5	4
---	---	---

### Hysteresis

D

0	3%
1	6%
2	10%

### Operational Delay

E

Value = 01 to 60 sec

### Relay Contact

F

0	Latching, Normally Open
1	Latching, Normally Closed
2	Non-Latching, Normally Open
3	Non-Latching, Normally Closed

### Power On Delay

G

0	3 sec
1	20 sec

### Startup Delay

H

0	Disabled
1	Enabled

I

0	Seconds
1	Minutes

J

Value = 01 to 60 sec. or 01 to 30 min.

### Alarm Threshold During Startup

(Multiplier of the Alarm Threshold)

K

0	x2
1	x4
2	x8
3	Blocked

### Residual Vibration Level

L

0	Dependent
1	Independent

M

Value = For **Dependent** 001 to 040% of Alarm Threshold.  
For **Independent** 0.01 to 5.00 ips  
00.1 to 90.0 mm/sec

Figure 39 – Ordering Guide

**Battery-Powered Signal Conditioner**

Power supply/signal conditioner (Model 480C02) is for use with the Smart Switch when determining the alarm threshold level using the MAVT™ feature. The built-in meter indicates when the process is complete. See [www.pcb.com](http://www.pcb.com) for product details.



**Figure 40 – Battery Powered Signal Conditioner**

**Calibration Cable**

The calibration cable (Model 052BR010AC) is a 10 foot, twisted-pair, shielded cable with a 2-Pin MIL type connector terminating to a BNC plug for use with 480C02 power supply and Smart Switch.



**Figure 41 – Calibration Cable**

**Magnet Clip**

The magnet clip (Model 080A214) is supplied as part of the optional 600A29 USB Programmer Kit or can be ordered separately for use with the MAVT™.





## Cable Ordering Information

Go to [www.pcb.com](http://www.pcb.com) for complete information on cables.

IMI Part Number: **052** **BR** **010** **BZ**

### Cable Model Series

- 052 Polyurethane, Shielded, Twisted Pair
- 048 Armored Polyurethane, Shielded, Twisted Pair

### Switch Connector Type

- AE 2 socket MIL type with environmental boot
- BP 2 socket MIL type high temp with strain relief
- BR 2 socket MIL type molded composite
- BQ 2 socket MIL type molded composite, right angle

### Cable Length

- 010 10 feet
- 020 20 feet
- 030 30 feet
- 040 40 feet
- 050 50 feet
- XXX Any length

### Cable termination

- BZ Blunt Cut
- (Consult factory for additional options)



**Warning 1 – ESD sensitivity**

---

**The power supply/signal conditioner should not be opened by anyone other than qualified service personnel.** This product is intended for use by qualified personnel who recognize shock hazards and are familiar with the safety precautions required to avoid injury.

**Warning 2 – ESD sensitivity**

---

This equipment is designed with user safety in mind; however, the protection provided by the equipment may be impaired if the equipment is used in a manner not specified by PCB Piezotronics, Inc.

**Caution 1 – ESD sensitivity**

---

**Cables can kill your equipment.** High voltage electrostatic discharge (ESD) can damage electrical devices. Similar to a capacitor, a cable can hold a charge caused by triboelectric transfer, such as that which occurs in the following:

- *Laying on and moving across a rug,*
- *Any movement through air,*
- *The action of rolling out a cable, and/or*
- *Contact with a non-grounded person.*

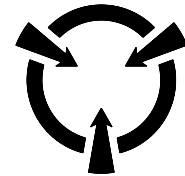

**CAUTION**  
ELECTROSTATIC  
DISCHARGE SENSITIVE

**The PCB solution for product safety:**

- *Connect the cables only with the AC power off.*
- *Temporarily “short” the end of the cable before attaching it to any signal input or output.*

**Caution 2 – ESD sensitivity**

---

**ESD considerations should be made prior to performing any internal adjustments on the equipment.** Any piece of electronic equipment is vulnerable to ESD when opened for adjustments. Internal adjustments should therefore be done ONLY at an ESD-safe work area. Many products have ESD protection, but the level of protection may be exceeded by extremely high voltage.



### **Warranty**

---

IMI instrumentation is warranted against defective material and workmanship for 1 year unless otherwise expressly specified. Damage to instruments caused by incorrect power or misapplication, is not covered by warranty. *If there are any questions regarding power, intended application, or general usage, please consult with your local sales contact or distributor.* Batteries and other expendable hardware items are not covered by warranty.

### **Service**

---

Because of the sophisticated nature of IMI instrumentation, field repair is typically **NOT** recommended and may void any warranty. If factory service is required, return the instrumentation according to the "Return Procedure" stated below. *A repair and/or replacement quotation will be provided prior to servicing at no charge.* Before returning the unit, please consult a factory IMI applications engineer concerning the situation as certain problems can often be corrected with simple on-site procedures.

### **Return Procedure**

---

*To expedite returned instrumentation, contact a factory IMI applications engineer for a RETURN MATERIAL AUTHORIZATION (RMA) NUMBER.* Please have information available such as model and serial number. Also, to insure efficient service, *provide a written description of the symptoms and problems with the equipment to a local sales representative or distributor, or contact IMI if none are located in your area.*

Customers outside the U.S. should consult their local IMI distributor for information on returning equipment. For exceptions, please contact the International Sales department at IMI to request shipping instructions and an RMA. For assistance, please call (716) 684-0003, or fax us at (716) 684-3823. You may also receive assistance via e-mail at [imi@pcb.com](mailto:imi@pcb.com) or visit our web site at [www.pcb.com](http://www.pcb.com).

### **Customer Service**

---

IMI, a division of PCB Piezotronics, guarantees **Total Customer Satisfaction**. If, at any time, for any reason, you are not completely satisfied with any IMI product, IMI will repair, replace, or exchange it at no charge. You may also choose to have your purchase price refunded.

IMI offers to all customers, at no charge, 24-hour phone support. This service makes product or application support available to our customers, day or night, seven days a week. When unforeseen problems or emergency situations arise, call the **IMI Hot Line at (716) 684-0003**, and an application specialist will assist you.

## Repair and Maintenance

PCB guarantees Total Customer Satisfaction through its “Lifetime Warranty Plus” on all Platinum Stock Products sold by PCB and through its limited warranties on all other PCB Stock, Standard and Special products. Due to the sophisticated nature of our sensors and associated instrumentation, **field servicing and repair is not recommended and, if attempted, will void the factory warranty.**

Beyond routine calibration and battery replacements where applicable, our products require no user maintenance. Clean electrical connectors, housings, and mounting surfaces with solutions and techniques that will not harm the material of construction. Observe caution when using liquids near devices that are not hermetically sealed. Such devices should only be wiped with a dampened cloth—never saturated or submerged.

In the event that equipment becomes damaged or ceases to operate, our Application Engineers are here to support your troubleshooting efforts 24 hours a day, 7 days a week. Call or email with model and serial number as well as a brief description of the problem.

## Calibration

Routine calibration of sensors and associated instrumentation is necessary to maintain measurement accuracy. We recommend calibrating on an annual basis, after exposure to any extreme environmental influence, or prior to any critical test.

PCB Piezotronics is an ISO-9001 certified company whose calibration services are accredited by A2LA to ISO/IEC 17025, with full traceability to SI through N.I.S.T. In addition to our standard calibration services, we also offer specialized tests, including: sensitivity at elevated or cryogenic temperatures, phase response, extended high or low frequency response, extended range, leak testing, hydrostatic pressure testing, and others. For more information, contact your local PCB Piezotronics distributor, sales representative, or factory customer service representative.

## Returning Equipment

If factory repair is required, our representatives will provide you with a Return Material Authorization (RMA) number, which we use to reference any information you have already provided and expedite the repair process. This number should be clearly marked on the outside of all returned package(s) and on any packing list(s) accompanying the shipment.

## Contact Information

PCB Piezotronics, Inc.  
3425 Walden Ave.  
Depew, NY14043 USA  
Toll-free: (800) 828-8840  
24-hour SensorLine: (716) 684-0001  
General inquiries: [info@pcb.com](mailto:info@pcb.com)  
Repair inquiries: [rma@pcb.com](mailto:rma@pcb.com)

For a complete list of distributors, global offices and sales representatives, visit our website, [www.pcb.com](http://www.pcb.com).

## Safety Considerations

This product is intended for use by qualified personnel who recognize shock hazards and are familiar with the precautions required to avoid injury. While our equipment is designed with user safety in mind, the protection provided by the equipment may be impaired if equipment is used in a manner not specified by this manual.

Discontinue use and contact our 24-Hour Sensorline if:

- Assistance is needed to safely operate equipment
- Damage is visible or suspected
- Equipment fails or malfunctions

For complete equipment ratings, refer to the enclosed specification sheet for your product.

## Definition of Terms and Symbols

The following symbols may be used in this manual:



### **DANGER**

Indicates an immediate hazardous situation, which, if not avoided, may result in death or serious injury.

**CAUTION**

Refers to hazards that could damage the instrument.

**NOTE**

Indicates tips, recommendations and important information. The notes simplify processes and contain additional information on particular operating steps.

**The following symbols may be found on the equipment described in this manual:**



This symbol on the unit indicates that high voltage may be present. Use standard safety precautions to avoid personal contact with this voltage.



This symbol on the unit indicates that the user should refer to the operating instructions located in the manual.



This symbol indicates safety, earth ground.



PCB工业监视和测量设备 - 中国RoHS2公布表

PCB Industrial Monitoring and Measuring Equipment - China RoHS 2 Disclosure Table

部件名称	有害物质					
	铅 (Pb)	汞 (Hg)	镉 (Cd)	六价铬 (Cr(VI))	多溴联苯 (PBB)	多溴二苯醚 (PBDE)
住房	0	0	0	0	0	0
PCB板	X	0	0	0	0	0
电气连接器	0	0	0	0	0	0
压电晶体	X	0	0	0	0	0
环氧	0	0	0	0	0	0
铁氟龙	0	0	0	0	0	0
电子	0	0	0	0	0	0
厚膜基板	0	0	X	0	0	0
电线	0	0	0	0	0	0
电缆	X	0	0	0	0	0
塑料	0	0	0	0	0	0
焊接	X	0	0	0	0	0
铜合金/黄铜	X	0	0	0	0	0
本表格依据 SJ/T 11364 的规定编制。						
0：表示该有害物质在该部件所有均质材料中的含量均在 GB/T 26572 规定的限量要求以下。						
X：表示该有害物质至少在该部件的某一均质材料中的含量超出 GB/T 26572 规定的限量要求。						
铅是欧洲RoHS指令2011/65/ EU附件三和附件四目前由于允许的豁免。						

CHINA RoHS COMPLIANCE

Component Name	Hazardous Substances					
	Lead (Pb)	Mercury (Hg)	Cadmium (Cd)	Chromium VI Compounds (Cr(VI))	Polybrominated Biphenyls (PBB)	Polybrominated Diphenyl Ethers (PBDE)
Housing	O	O	O	O	O	O
PCB Board	X	O	O	O	O	O
Electrical Connectors	O	O	O	O	O	O
Piezoelectric Crystals	X	O	O	O	O	O
Epoxy	O	O	O	O	O	O
Teflon	O	O	O	O	O	O
Electronics	O	O	O	O	O	O
Thick Film Substrate	O	O	X	O	O	O
Wires	O	O	O	O	O	O
Cables	X	O	O	O	O	O
Plastic	O	O	O	O	O	O
Solder	X	O	O	O	O	O
Copper Alloy/Brass	X	O	O	O	O	O

This table is prepared in accordance with the provisions of SJ/T 11364.

O: Indicates that said hazardous substance contained in all of the homogeneous materials for this part is below the limit requirement of GB/T 26572.

X: Indicates that said hazardous substance contained in at least one of the homogeneous materials for this part is above the limit requirement of GB/T 26572.

Lead is present due to allowed exemption in Annex III or Annex IV of the European RoHS Directive 2011/65/EU.

Model Number <b>070A100</b>	<b>686 SERIES USB PROGRAMMER</b>	Revision: NR ECN #: 46328
--------------------------------	----------------------------------	------------------------------

<b>Performance</b>	<u>ENGLISH</u>	<u>SI</u>
Cable Style	Multi Conductor - Shielded	Multi Conductor - Shielded
Number of Conductors	2	2
Connector Model(sensor side)	AE	AE
Connector Style(sensor side)	MIL-C-5015	MIL-C-5015
Connection Type(sensor side)	2-socket	2-socket
Coupling Method(sensor side)	Push-on	Push-on
Connector Style(termination)	USB 2.0 - 5VDC	USB 2.0 - 5VDC
Connection Type(termination)	USB Series A	USB Series A
Coupling Method(termination)	Push-on	Push-on
<b>Physical</b>		
Size (Length x Height x Width)(termination)	2.0 in x 0.5 in x 1.0 in	50.8 mm x 12.7 mm x 25.4 mm
Cable Jacket Diameter	0.16 in	4.1 mm
Cable Jacket Material	Polyurethane	Polyurethane
Cable Jacket Color	Black	Black
Weight	0.15 lb	70 g
Size (Length)(Cable Assembly)	3 ft	0.91 m
<i>All specifications are at room temperature unless otherwise specified. In the interest of constant product improvement, we reserve the right to change specifications without notice.</i>		

**OPTIONAL VERSIONS**

Optional versions have identical specifications and accessories as listed for the standard model except where noted below. More than one option may be used.

Entered: LK	Engineer: gs	Sales: MC	Approved: BAM	Spec Number:
Date: 1/24/2017	Date: 1/24/2017	Date: 1/24/2017	Date: 1/24/2017	<b>66334</b>



**IMI SENSORS**  
**3425 Walden**  
**Depew, NY 14043**  
**UNITED STATES**  
**Phone: 800-959-4464**  
**Fax: 716-684-3823**  
**E-Mail: imi@pcb.com**  
**Web site: http://www.imi-sensors.com**



**Model EX686B01**

**Intrinsically-safe USB programmable electronic vibration switch with 2-pin MIL-C-5015 connector**

**Installation and Operating Manual**

**For assistance with the operation of this product,  
contact the PCB Piezotronics, Inc.**

**Toll-free: 800-959-4464**

**24-hour SensorLine: 716-684-0001**

**Fax: 716-684-3823**

**E-mail: [imi@pcb.com](mailto:imi@pcb.com)**

**Web: [www.imi-sensors.com](http://www.imi-sensors.com)**



## Repair and Maintenance

PCB guarantees Total Customer Satisfaction through its “Lifetime Warranty Plus” on all Platinum Stock Products sold by PCB and through its limited warranties on all other PCB Stock, Standard and Special products. Due to the sophisticated nature of our sensors and associated instrumentation, **field servicing and repair is not recommended and, if attempted, will void the factory warranty.**

Beyond routine calibration and battery replacements where applicable, our products require no user maintenance. Clean electrical connectors, housings, and mounting surfaces with solutions and techniques that will not harm the material of construction. Observe caution when using liquids near devices that are not hermetically sealed. Such devices should only be wiped with a dampened cloth—never saturated or submerged.

In the event that equipment becomes damaged or ceases to operate, our Application Engineers are here to support your troubleshooting efforts 24 hours a day, 7 days a week. Call or email with model and serial number as well as a brief description of the problem.

## Calibration

Routine calibration of sensors and associated instrumentation is necessary to maintain measurement accuracy. We recommend calibrating on an annual basis, after exposure to any extreme environmental influence, or prior to any critical test.

PCB Piezotronics is an ISO-9001 certified company whose calibration services are accredited by A2LA to ISO/IEC 17025, with full traceability to SI through N.I.S.T. In addition to our standard calibration services, we also offer specialized tests, including: sensitivity at elevated or cryogenic temperatures, phase response, extended high or low frequency response, extended range, leak testing, hydrostatic pressure testing, and others. For more information, contact your local PCB Piezotronics distributor, sales representative, or factory customer service representative.

## Returning Equipment

If factory repair is required, our representatives will provide you with a Return Material Authorization (RMA) number, which we use to reference any information you have already provided and expedite the repair process. This number should be clearly marked on the outside of all returned package(s) and on any packing list(s) accompanying the shipment.

## Contact Information

PCB Piezotronics, Inc.  
3425 Walden Ave.  
Depew, NY14043 USA  
Toll-free: (800) 828-8840  
24-hour SensorLine: (716) 684-0001  
General inquiries: [info@pcb.com](mailto:info@pcb.com)  
Repair inquiries: [rma@pcb.com](mailto:rma@pcb.com)

For a complete list of distributors, global offices and sales representatives, visit our website, [www.pcb.com](http://www.pcb.com).

## Safety Considerations

This product is intended for use by qualified personnel who recognize shock hazards and are familiar with the precautions required to avoid injury. While our equipment is designed with user safety in mind, the protection provided by the equipment may be impaired if equipment is used in a manner not specified by this manual.

Discontinue use and contact our 24-Hour Sensorline if:

- Assistance is needed to safely operate equipment
- Damage is visible or suspected
- Equipment fails or malfunctions

For complete equipment ratings, refer to the enclosed specification sheet for your product.

## Definition of Terms and Symbols

The following symbols may be used in this manual:



### DANGER

Indicates an immediate hazardous situation, which, if not avoided, may result in death or serious injury.



**CAUTION**

Refers to hazards that could damage the instrument.

**NOTE**

Indicates tips, recommendations and important information. The notes simplify processes and contain additional information on particular operating steps.

**The following symbols may be found on the equipment described in this manual:**



This symbol on the unit indicates that high voltage may be present. Use standard safety precautions to avoid personal contact with this voltage.



This symbol on the unit indicates that the user should refer to the operating instructions located in the manual.



This symbol indicates safety, earth ground.



PCB工业监视和测量设备 - 中国RoHS2公布表

PCB Industrial Monitoring and Measuring Equipment - China RoHS 2 Disclosure Table

部件名称	有害物质					
	铅 (Pb)	汞 (Hg)	镉 (Cd)	六价铬 (Cr(VI))	多溴联苯 (PBB)	多溴二苯醚 (PBDE)
住房	0	0	0	0	0	0
PCB板	X	0	0	0	0	0
电气连接器	0	0	0	0	0	0
压电晶体	X	0	0	0	0	0
环氧	0	0	0	0	0	0
铁氟龙	0	0	0	0	0	0
电子	0	0	0	0	0	0
厚膜基板	0	0	X	0	0	0
电线	0	0	0	0	0	0
电缆	X	0	0	0	0	0
塑料	0	0	0	0	0	0
焊接	X	0	0	0	0	0
铜合金/黄铜	X	0	0	0	0	0
本表格依据 SJ/T 11364 的规定编制。						
0：表示该有害物质在该部件所有均质材料中的含量均在 GB/T 26572 规定的限量要求以下。						
X：表示该有害物质至少在该部件的某一均质材料中的含量超出 GB/T 26572 规定的限量要求。						
铅是欧洲RoHS指令2011/65/ EU附件三和附件四目前由于允许的豁免。						

CHINA RoHS COMPLIANCE

Component Name	Hazardous Substances					
	Lead (Pb)	Mercury (Hg)	Cadmium (Cd)	Chromium VI Compounds (Cr(VI))	Polybrominated Biphenyls (PBB)	Polybrominated Diphenyl Ethers (PBDE)
Housing	O	O	O	O	O	O
PCB Board	X	O	O	O	O	O
Electrical Connectors	O	O	O	O	O	O
Piezoelectric Crystals	X	O	O	O	O	O
Epoxy	O	O	O	O	O	O
Teflon	O	O	O	O	O	O
Electronics	O	O	O	O	O	O
Thick Film Substrate	O	O	X	O	O	O
Wires	O	O	O	O	O	O
Cables	X	O	O	O	O	O
Plastic	O	O	O	O	O	O
Solder	X	O	O	O	O	O
Copper Alloy/Brass	X	O	O	O	O	O

This table is prepared in accordance with the provisions of SJ/T 11364.

O: Indicates that said hazardous substance contained in all of the homogeneous materials for this part is below the limit requirement of GB/T 26572.

X: Indicates that said hazardous substance contained in at least one of the homogeneous materials for this part is above the limit requirement of GB/T 26572.

Lead is present due to allowed exemption in Annex III or Annex IV of the European RoHS Directive 2011/65/EU.

	ENGLISH	SI
<b>Performance</b>		
Alarm Threshold(± 10 %)	0.25 to 5 in/sec pk	4.5 to 90 mm/s rms
Frequency Range(± 3 dB)	420 to 60 kcpm	7 to 1000 Hz
Hysteresis(% < Alarm Threshold)	3; 6; or 10 %	3; 6; or 10 %
Residual Vibration Level(Reference)	Dependent or Independent	Dependent or Independent
Residual Vibration Level(% Alarm Threshold)	1 to 40 %	1 to 40 %
MAVT(Sets Alarm Threshold to 2X actual vibration)	Enabled or Disabled	Enabled or Disabled
Transverse Sensitivity	<7 %	<7 %
Power On Delay(± 1 sec)	3 or 20 sec	3 or 20 sec
Startup Delay(± 1 sec or 1 min)(Time)	1 to 60 sec or 1 to 30 min	1 to 60 sec or 1 to 30 min
Startup Delay(x Alarm Threshold)	x2; x4; x8; Blocked	x2; x4; x8; Blocked
Startup Delay(Active)	Enabled or Disabled	Enabled or Disabled
Operational Delay(± 1 sec)	1 to 60 sec	1 to 60 sec
Relay(Type)	SPST, Form A or B MOSFET	SPST, Form A or B MOSFET
Relay(Latching)	Latching / Non-Latching	Latching / Non-Latching
Relay(Contacts)	Normally Open / Closed	Normally Open / Closed
<b>Environmental</b>		
Temperature Range(Operating)	-40 to 185 °F	-40 to 85 °C
Temperature Range(Storage)	-40 to 257 °F	-40 to 125 °C
Overload Limit(Shock)	5000 g pk	49,050 m/s <sup>2</sup> pk
Enclosure Rating	IP68	IP68
<b>Electrical</b>		
Power Required	24 to 240 V DC/AC 50/60 Hz	24 to 240 V DC/AC 50/60 Hz
Current Rating(Relay Closed)	500 mA	500 mA
Leak Current(Relay Open)	≤ 1 mA	≤ 1 mA
Electrical Isolation(Case)	>10 <sup>8</sup> Ohm	>10 <sup>8</sup> Ohm
<b>Physical</b>		
Size (Hex x Height)	1.25 in x 2.6 in	1.25 in x 66 mm
Weight	5.2 oz	148 gm
Mounting Torque	3 to 5 ft-lb	4 to 7 Nm
Mounting Thread	1/4-28 Female	1/4-28 Female
Sensing Element(Internal)	Piezoelectric Accelerometer	Piezoelectric Accelerometer
Housing Material	Stainless Steel	Stainless Steel
Sealing	Welded Hermetic	Welded Hermetic
Electrical Connector	2-Pin MIL-C-5015	2-Pin MIL-C-5015
Electrical Connection Position	Top	Top

**OPTIONAL VERSIONS**

Optional versions have identical specifications and accessories as listed for the standard model except where noted below. More than one option may be used.

**EX - Hazardous Area Approval-** contact factory for specific approvals

Current Rating(Relay Closed)	100 mA	100 mA
Hazardous Area Approval	CI I, Div 2, Groups A, B, C, D; Ex nL IICT3, AEx nA IICT3	CI I, Div 2, Groups A, B, C, D; Ex nL IICT3, AEx nA IICT3
Power Required	10 to 30 VDC	10 to 30 VDC
Relay(Capacity)	10 to 30 VDC, 100 mA	10 to 30 VDC, 100 mA

**M - Metric Mount**  
Supplied Accessory : Model M081A61 Mounting Stud 1/4-28 to M6 X 1 (1)

**NOTES:**

[1] USB Programmable - See configuration sheet supplied with switch for exact setting.  
[2] See PCB Declaration of Conformance PS023 or PS060 for details.

**SUPPLIED ACCESSORIES:**  
Model 081A41 Mounting stud 1/4-28 socket head set screw brass tip stainless steel 5/8" long (1)

Entered: AP	Engineer: do	Sales: EGY	Approved: BAM	Spec Number:
Date: 9/4/2012	Date: 9/4/2012	Date: 9/4/2012	Date: 9/4/2012	<b>40110</b>

  
**IMI SENSORS**  
 A PCB PIEZOTRONICS DIV.  
 3425 Walden Avenue, Depew, NY 14043

**Phone: 800-959-4464**  
**Fax: 716-684-3823**  
**E-Mail: imi@pcb.com**



*All specifications are at room temperature unless otherwise specified.  
In the interest of constant product improvement, we reserve the right to change specifications without notice.*

2

1

PCB Piezotronics Inc. claims proprietary rights in the information disclosed hereon. Neither it nor any reproduction thereof will be disclosed to others without the written consent of PCB Piezotronics Inc.

REVISIONS

REV	DESCRIPTION	DIN
B	REVISED TITLE	46960

40111

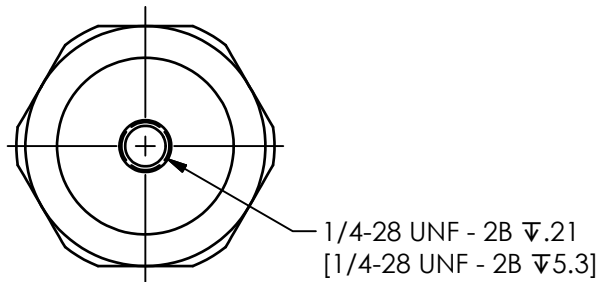
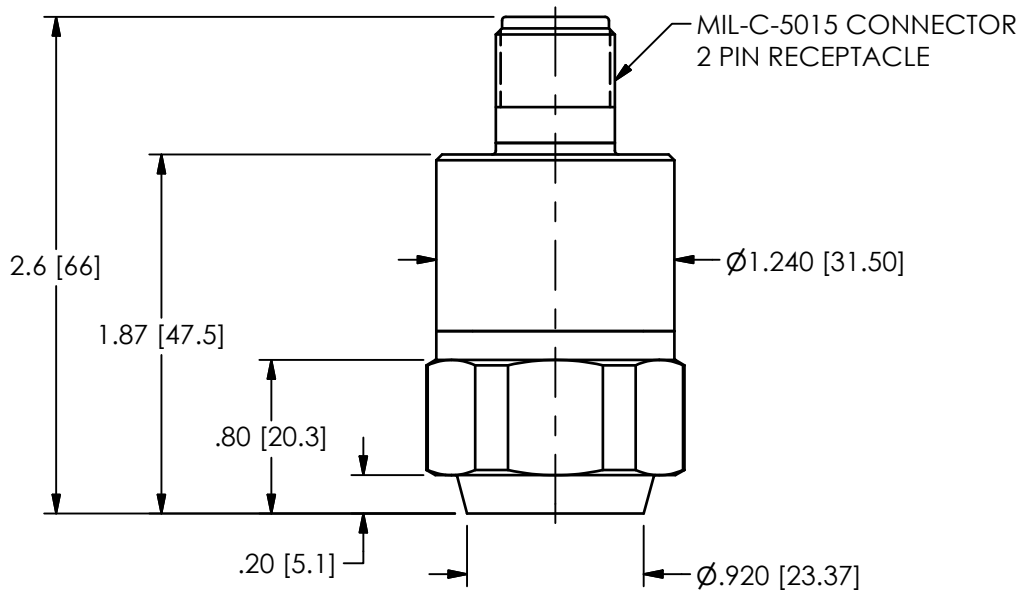
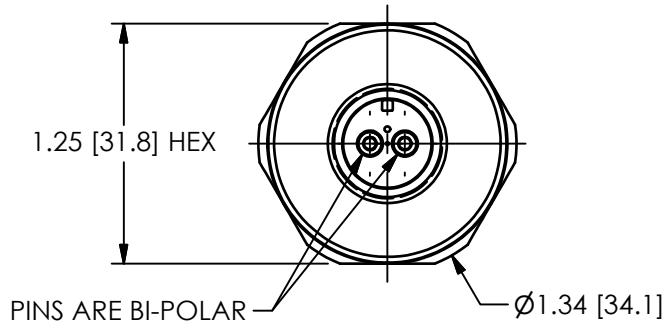

UNLESS OTHERWISE SPECIFIED TOLERANCES ARE:

DRAWN		CHECKED		ENGINEER	
KRM	7/11/17	JDM	7/11/17	BAM	7/11/17

DIMENSIONS IN INCHES	DIMENSIONS IN MILLIMETERS [IN BRACKETS]
DECIMALS XX ±.03 XXX ±.010	DECIMALS X ± 0.8 XX ± 0.25
ANGLES ± 2 DEGREES	ANGLES ± 2 DEGREES

FILLETS AND RADII	FILLETS AND RADII
.003 - .005	0.07 - 0.13

TITLE

OUTLINE DRAWING  
MODEL 686B & 686C SERIES  
VIBRATION SWITCH

**PCB PIEZOTRONICS™**  
3425 WALDEN AVE. DEPEW, NY 14043  
(716) 684-0001 E-MAIL: sales@pcb.com

CODE IDENT. NO. 52681	DWG. NO. 40111
SCALE: FULL	SHEET 1 OF 1

2

1

1

## Repair and Maintenance

PCB guarantees Total Customer Satisfaction through its “Lifetime Warranty Plus” on all Platinum Stock Products sold by PCB and through its limited warranties on all other PCB Stock, Standard and Special products. Due to the sophisticated nature of our sensors and associated instrumentation, **field servicing and repair is not recommended and, if attempted, will void the factory warranty.**

Beyond routine calibration and battery replacements where applicable, our products require no user maintenance. Clean electrical connectors, housings, and mounting surfaces with solutions and techniques that will not harm the material of construction. Observe caution when using liquids near devices that are not hermetically sealed. Such devices should only be wiped with a dampened cloth—never saturated or submerged.

In the event that equipment becomes damaged or ceases to operate, our Application Engineers are here to support your troubleshooting efforts 24 hours a day, 7 days a week. Call or email with model and serial number as well as a brief description of the problem.

## Calibration

Routine calibration of sensors and associated instrumentation is necessary to maintain measurement accuracy. We recommend calibrating on an annual basis, after exposure to any extreme environmental influence, or prior to any critical test.

PCB Piezotronics is an ISO-9001 certified company whose calibration services are accredited by A2LA to ISO/IEC 17025, with full traceability to SI through N.I.S.T. In addition to our standard calibration services, we also offer specialized tests, including: sensitivity at elevated or cryogenic temperatures, phase response, extended high or low frequency response, extended range, leak testing, hydrostatic pressure testing, and others. For more information, contact your local PCB Piezotronics distributor, sales representative, or factory customer service representative.

## Returning Equipment

If factory repair is required, our representatives will provide you with a Return Material Authorization (RMA) number, which we use to reference any information you have already provided and expedite the repair process. This number should be clearly marked on the outside of all returned package(s) and on any packing list(s) accompanying the shipment.

## Contact Information

PCB Piezotronics, Inc.  
3425 Walden Ave.  
Depew, NY14043 USA  
Toll-free: (800) 828-8840  
24-hour SensorLine: (716) 684-0001  
General inquiries: [info@pcb.com](mailto:info@pcb.com)  
Repair inquiries: [rma@pcb.com](mailto:rma@pcb.com)

For a complete list of distributors, global offices and sales representatives, visit our website, [www.pcb.com](http://www.pcb.com).

## Safety Considerations

This product is intended for use by qualified personnel who recognize shock hazards and are familiar with the precautions required to avoid injury. While our equipment is designed with user safety in mind, the protection provided by the equipment may be impaired if equipment is used in a manner not specified by this manual.

Discontinue use and contact our 24-Hour Sensorline if:

- Assistance is needed to safely operate equipment
- Damage is visible or suspected
- Equipment fails or malfunctions

For complete equipment ratings, refer to the enclosed specification sheet for your product.

## Definition of Terms and Symbols

The following symbols may be used in this manual:



### DANGER

Indicates an immediate hazardous situation, which, if not avoided, may result in death or serious injury.

**CAUTION**

Refers to hazards that could damage the instrument.

**NOTE**

Indicates tips, recommendations and important information. The notes simplify processes and contain additional information on particular operating steps.

**The following symbols may be found on the equipment described in this manual:**



This symbol on the unit indicates that high voltage may be present. Use standard safety precautions to avoid personal contact with this voltage.



This symbol on the unit indicates that the user should refer to the operating instructions located in the manual.



This symbol indicates safety, earth ground.



PCB工业监视和测量设备 - 中国RoHS2公布表

PCB Industrial Monitoring and Measuring Equipment - China RoHS 2 Disclosure Table

部件名称	有害物质					
	铅 (Pb)	汞 (Hg)	镉 (Cd)	六价铬 (Cr(VI))	多溴联苯 (PBB)	多溴二苯醚 (PBDE)
住房	0	0	0	0	0	0
PCB板	X	0	0	0	0	0
电气连接器	0	0	0	0	0	0
压电晶体	X	0	0	0	0	0
环氧	0	0	0	0	0	0
铁氟龙	0	0	0	0	0	0
电子	0	0	0	0	0	0
厚膜基板	0	0	X	0	0	0
电线	0	0	0	0	0	0
电缆	X	0	0	0	0	0
塑料	0	0	0	0	0	0
焊接	X	0	0	0	0	0
铜合金/黄铜	X	0	0	0	0	0
本表格依据 SJ/T 11364 的规定编制。						
0：表示该有害物质在该部件所有均质材料中的含量均在 GB/T 26572 规定的限量要求以下。						
X：表示该有害物质至少在该部件的某一均质材料中的含量超出 GB/T 26572 规定的限量要求。						
铅是欧洲RoHS指令2011/65/ EU附件三和附件四目前由于允许的豁免。						

CHINA RoHS COMPLIANCE



Component Name	Hazardous Substances					
	Lead (Pb)	Mercury (Hg)	Cadmium (Cd)	Chromium VI Compounds (Cr(VI))	Polybrominated Biphenyls (PBB)	Polybrominated Diphenyl Ethers (PBDE)
Housing	O	O	O	O	O	O
PCB Board	X	O	O	O	O	O
Electrical Connectors	O	O	O	O	O	O
Piezoelectric Crystals	X	O	O	O	O	O
Epoxy	O	O	O	O	O	O
Teflon	O	O	O	O	O	O
Electronics	O	O	O	O	O	O
Thick Film Substrate	O	O	X	O	O	O
Wires	O	O	O	O	O	O
Cables	X	O	O	O	O	O
Plastic	O	O	O	O	O	O
Solder	X	O	O	O	O	O
Copper Alloy/Brass	X	O	O	O	O	O

This table is prepared in accordance with the provisions of SJ/T 11364.

O: Indicates that said hazardous substance contained in all of the homogeneous materials for this part is below the limit requirement of GB/T 26572.

X: Indicates that said hazardous substance contained in at least one of the homogeneous materials for this part is above the limit requirement of GB/T 26572.

Lead is present due to allowed exemption in Annex III or Annex IV of the European RoHS Directive 2011/65/EU.

66335

PCB Piezotronics Inc. claims proprietary rights in the information disclosed hereon. Neither it nor any reproduction thereof will be disclosed to others without the written consent of PCB Piezotronics Inc.

REVISIONS		
REV	DESCRIPTION	DIN
A	UPDATED LABEL	47195

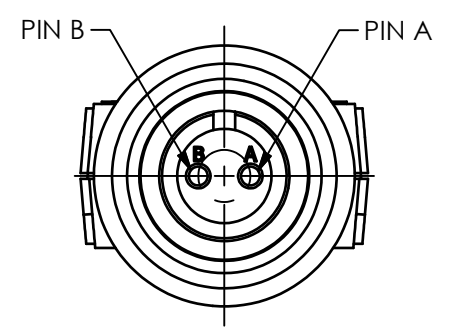
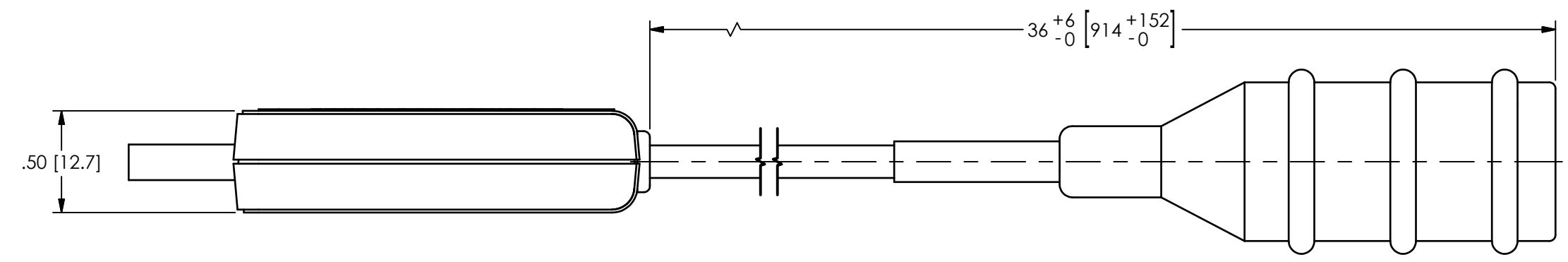
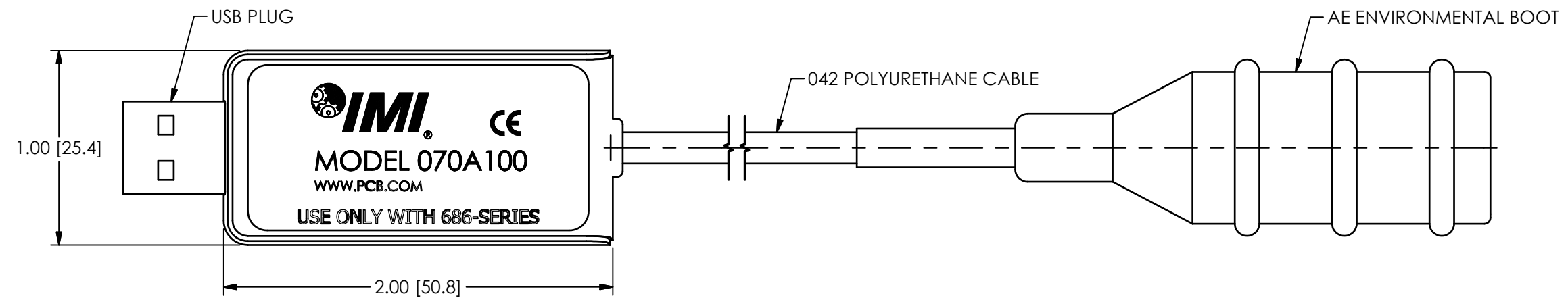

UNLESS OTHERWISE SPECIFIED TOLERANCES ARE:		DRAWN		CHECKED		ENGINEER			
DIMENSIONS IN INCHES	DIMENSIONS IN MILLIMETERS [IN BRACKETS]	ECB	10/10/17	ECB	10/10/17	GGG	10/10/17		
DECIMALS XX ±.03 XXX ±.010	DECIMALS X ±0.8 XX ±0.25	TITLE OUTLINE DRAWING MODEL 070A100 PROGRAMER							
ANGLES ± 2 DEGREES	ANGLES ± 2 DEGREES							3425 WALDEN AVE. DEPEW, NY 14043 (716) 684-0001 E-MAIL: sales@pcb.com	
FILLETS AND RADII .003 - .005	FILLETS AND RADII 0.07 - 0.13	CODE IDENT. NO. 52681		DWG. NO. 66335		SCALE: 1.5X		SHEET 1 OF 1	



**Model EX686B01**

**Intrinsically-safe USB programmable electronic vibration switch with 2-pin MIL-C-5015 connector**

**Installation and Operating Manual**

**For assistance with the operation of this product,  
contact the PCB Piezotronics, Inc.**

**Toll-free: 800-959-4464**

**24-hour SensorLine: 716-684-0001**

**Fax: 716-684-3823**

**E-mail: [imi@pcb.com](mailto:imi@pcb.com)**

**Web: [www.imi-sensors.com](http://www.imi-sensors.com)**



## Repair and Maintenance

PCB guarantees Total Customer Satisfaction through its “Lifetime Warranty Plus” on all Platinum Stock Products sold by PCB and through its limited warranties on all other PCB Stock, Standard and Special products. Due to the sophisticated nature of our sensors and associated instrumentation, **field servicing and repair is not recommended and, if attempted, will void the factory warranty.**

Beyond routine calibration and battery replacements where applicable, our products require no user maintenance. Clean electrical connectors, housings, and mounting surfaces with solutions and techniques that will not harm the material of construction. Observe caution when using liquids near devices that are not hermetically sealed. Such devices should only be wiped with a dampened cloth—never saturated or submerged.

In the event that equipment becomes damaged or ceases to operate, our Application Engineers are here to support your troubleshooting efforts 24 hours a day, 7 days a week. Call or email with model and serial number as well as a brief description of the problem.

## Calibration

Routine calibration of sensors and associated instrumentation is necessary to maintain measurement accuracy. We recommend calibrating on an annual basis, after exposure to any extreme environmental influence, or prior to any critical test.

PCB Piezotronics is an ISO-9001 certified company whose calibration services are accredited by A2LA to ISO/IEC 17025, with full traceability to SI through N.I.S.T. In addition to our standard calibration services, we also offer specialized tests, including: sensitivity at elevated or cryogenic temperatures, phase response, extended high or low frequency response, extended range, leak testing, hydrostatic pressure testing, and others. For more information, contact your local PCB Piezotronics distributor, sales representative, or factory customer service representative.

## Returning Equipment

If factory repair is required, our representatives will provide you with a Return Material Authorization (RMA) number, which we use to reference any information you have already provided and expedite the repair process. This number should be clearly marked on the outside of all returned package(s) and on any packing list(s) accompanying the shipment.

## Contact Information

PCB Piezotronics, Inc.  
3425 Walden Ave.  
Depew, NY14043 USA  
Toll-free: (800) 828-8840  
24-hour SensorLine: (716) 684-0001  
General inquiries: [info@pcb.com](mailto:info@pcb.com)  
Repair inquiries: [rma@pcb.com](mailto:rma@pcb.com)

For a complete list of distributors, global offices and sales representatives, visit our website, [www.pcb.com](http://www.pcb.com).

## Safety Considerations

This product is intended for use by qualified personnel who recognize shock hazards and are familiar with the precautions required to avoid injury. While our equipment is designed with user safety in mind, the protection provided by the equipment may be impaired if equipment is used in a manner not specified by this manual.

Discontinue use and contact our 24-Hour Sensorline if:

- Assistance is needed to safely operate equipment
- Damage is visible or suspected
- Equipment fails or malfunctions

For complete equipment ratings, refer to the enclosed specification sheet for your product.

## Definition of Terms and Symbols

The following symbols may be used in this manual:



### **DANGER**

Indicates an immediate hazardous situation, which, if not avoided, may result in death or serious injury.

**CAUTION**

Refers to hazards that could damage the instrument.

**NOTE**

Indicates tips, recommendations and important information. The notes simplify processes and contain additional information on particular operating steps.

**The following symbols may be found on the equipment described in this manual:**



This symbol on the unit indicates that high voltage may be present. Use standard safety precautions to avoid personal contact with this voltage.



This symbol on the unit indicates that the user should refer to the operating instructions located in the manual.



This symbol indicates safety, earth ground.



PCB工业监视和测量设备 - 中国RoHS2公布表

PCB Industrial Monitoring and Measuring Equipment - China RoHS 2 Disclosure Table

部件名称	有害物质					
	铅 (Pb)	汞 (Hg)	镉 (Cd)	六价铬 (Cr(VI))	多溴联苯 (PBB)	多溴二苯醚 (PBDE)
住房	0	0	0	0	0	0
PCB板	X	0	0	0	0	0
电气连接器	0	0	0	0	0	0
压电晶体	X	0	0	0	0	0
环氧	0	0	0	0	0	0
铁氟龙	0	0	0	0	0	0
电子	0	0	0	0	0	0
厚膜基板	0	0	X	0	0	0
电线	0	0	0	0	0	0
电缆	X	0	0	0	0	0
塑料	0	0	0	0	0	0
焊接	X	0	0	0	0	0
铜合金/黄铜	X	0	0	0	0	0
本表格依据 SJ/T 11364 的规定编制。						
0：表示该有害物质在该部件所有均质材料中的含量均在 GB/T 26572 规定的限量要求以下。						
X：表示该有害物质至少在该部件的某一均质材料中的含量超出 GB/T 26572 规定的限量要求。						
铅是欧洲RoHS指令2011/65/ EU附件三和附件四目前由于允许的豁免。						

CHINA RoHS COMPLIANCE

Component Name	Hazardous Substances					
	Lead (Pb)	Mercury (Hg)	Cadmium (Cd)	Chromium VI Compounds (Cr(VI))	Polybrominated Biphenyls (PBB)	Polybrominated Diphenyl Ethers (PBDE)
Housing	O	O	O	O	O	O
PCB Board	X	O	O	O	O	O
Electrical Connectors	O	O	O	O	O	O
Piezoelectric Crystals	X	O	O	O	O	O
Epoxy	O	O	O	O	O	O
Teflon	O	O	O	O	O	O
Electronics	O	O	O	O	O	O
Thick Film Substrate	O	O	X	O	O	O
Wires	O	O	O	O	O	O
Cables	X	O	O	O	O	O
Plastic	O	O	O	O	O	O
Solder	X	O	O	O	O	O
Copper Alloy/Brass	X	O	O	O	O	O

This table is prepared in accordance with the provisions of SJ/T 11364.

O: Indicates that said hazardous substance contained in all of the homogeneous materials for this part is below the limit requirement of GB/T 26572.

X: Indicates that said hazardous substance contained in at least one of the homogeneous materials for this part is above the limit requirement of GB/T 26572.

Lead is present due to allowed exemption in Annex III or Annex IV of the European RoHS Directive 2011/65/EU.

PCB Piezotronics Inc. claims proprietary rights in the information disclosed hereon. Neither it nor any reproduction thereof will be disclosed to others without the written consent of PCB Piezotronics Inc.

**SCHEDULE DRAWING**

NO MODIFICATIONS PERMITTED WITHOUT REFERENCE TO THE NOTIFIED BODY

39483

REVISIONS		
REV	DESCRIPTION	DIN
A	UPDATES NOTES	50106

- 12.) NE PAS DÉBRANCHER LORSQU'UN EMPLACEMENT DANGEREUX EST PRÉSENT
- 11.) DO NOT DISCONNECT WHEN HAZARDOUS LOCATION IS PRESENT
- 10.) NE PAS DÉBRANCHER LORSQUE ÉNERGÉ
- 9.) DO NOT DISCONNECT WHEN ENERGIZED
- 8. SHIELDS TO BE EARTHED AT SUPPLY END
- 7. THE INSTALLER SHALL INSURE THAT THE TRANSDUCER MOUNTING STRUCTURE IS AT THE SAME GROUNDING POTENTIAL AS THE SUPPLY GROUND. TOTAL EARTH LOOP IMPEDANCE SHALL BE LESS THAN ONE OHM

6. ENTITY APPLICATION:

SUPPLY:	I.S. Apparatus:
Voc/Uo <=	VMAX /Ui
Isc/Io <=	IMAX /Ii
Ca/Co >	Ci + CCABLE
La/Lo >	Li + LCABLE

SUPPLIES/CONDITIONERS WITHIN THE SPECIFIED LIMITATIONS ARE PERMITTED

ENTITY PARAMETERS (INTEGRAL CABLE VERSION):

- Ui = 30 V
- Ii = 100 mA
- Pi = 1 W
- Ci = 61 nF
- Li = 333 uH

ENTITY PARAMETERS (CONNECTOR VERSION):

- Ui = 30 V
- Ii = 100 mA
- Pi = 1 W
- Ci = 0
- Li = 28 uH

- 5.) EQUIPMENT CONSISTS OF TRANSIENT PROTECTION DEVICE TO BE SET AT A LEVEL NOT EXCEEDING 140% OF RATED POWER SUPPLY VOLTAGE (30V)
- 4.) FOR GUIDANCE ON CANADIAN INSTALLATION, REFER TO CEC PART I. FOR GUIDANCE ON U.S. INSTALLATION, INSTALL IN ACCORDANCE WITH NEC [ANSI/NFPA70] AND [ANSI/ISA RP12.6]
- 3.) CERTIFIED BY THE APPROPRIATE APPROVAL AUTHORITY FOR CONNECTION TO THE FOLLOWING AREAS:
  - ZONE 2
    - ExnL IIC T3
    - AExnA IIC T3
  - DIV 2
    - N.I. CLASS I, DIV 2, GROUPS A,B,C,D
- 2.) WIRING (CABLE CONFIGURED MODELS):
  - 2 CONDUCTOR CABLE
  - 0.25 INCH(6.4MM) X 1000 FEET (305 METERS) MAX
  - RED/PIN A (POWER)
  - BLUE/PIN B (RETURN)

THE -XXXXX FOLLOWING PART NUMBER SPECIFIES THE CABLE LENGTH AND TERMINATION TYPE FOR METRIC LENGTHS, CABLE DESIGNATION IS MXXXXX

- 1.) THE MODEL EX686XXXXXXX COVERS THE FOLLOWING OPTIONS, BUT NOT LIMITED TO:
  - CONNECTOR WITH PRE-CONFIGURED PROGRAM
  - CABLE WITH PRE-CONFIGURED PROGRAM
  - ARMORED CABLE WITH PRE-CONFIGURED PROGRAM
  - FIXED/MAVT/USB PROGRAMMABLE CONFIGURATION
  - THRESHOLD VALUE
  - SWITCH TIME DELAY
  - SWITCH CONFIGURATION AND START DELAY
  - CONNECTOR/CABLE/ARMOR CONFIGURATION

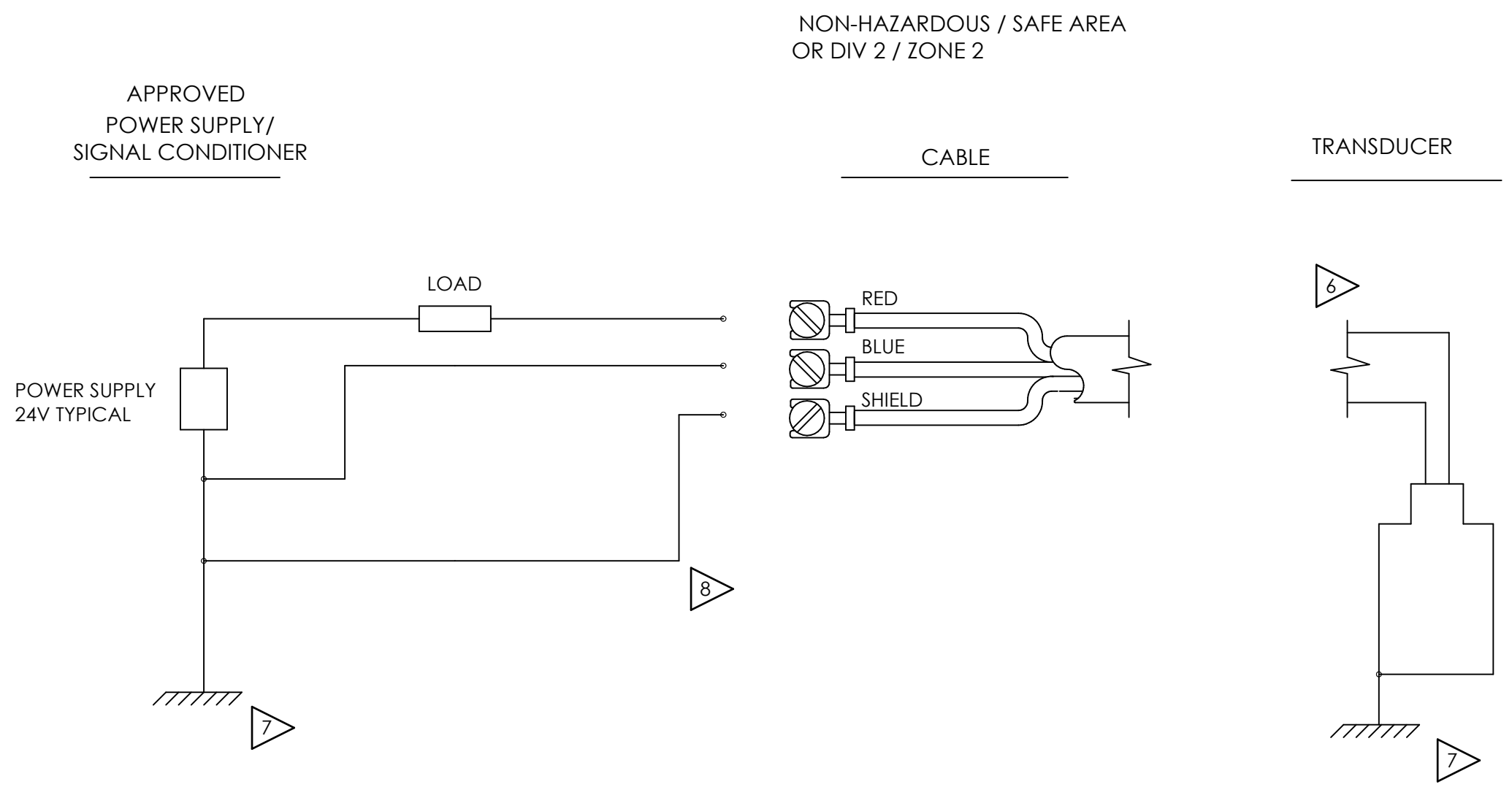

UNLESS OTHERWISE SPECIFIED	
DIMENSIONS ARE IN INCHES	
DECIMALS	X ± .05
	XX ± .01
	XXX ± .005
	XXXX ± .0005
ANGLES	± 2 DEGREES
FILLET AND RADII	.003 - .005
HEX DIMENSIONS ARE:	
	≤ .5 + .000 / - .003
	> .5 + .000 / - .005
INTERNAL THREAD DEPTH MIN.	
REMOVE ALL BURRS	
SHARP = R.000 - R.003	

DRAWN		CHECKED		ENGINEER	
KSR	12/18/19	KSR	12/18/19	GGG	12/18/19
TITLE					
APPROVAL EX686XXXXXXX INTERCONNECTION					

**PCB PIEZOTRONICS**  
AN AMPHENOL COMPANY

3425 WALDEN AVE. DEPEW, NY 14043  
(716) 684-0002 E-MAIL: sales@pcb.com

CODE IDENT. NO. 52681

DWG. NO. 39483

SCALE: NONE SHEET 1 OF 1



## EU Declaration of Conformity PS060

*In Accordance with ISO/IEC 17050*

**Manufacturer:**  
 PCB Piezotronics, Inc.  
 3425 Walden Avenue  
 Depew, New York 14043  
 USA

**Authorized European Representative:**  
 PCB Piezotronics Europe GmbH  
 Porschestraße 20-30  
 41836 Hückelhoven  
 Germany

**Certifies that type of equipment:** ICP® Industrial Sensor(s)

**Whose Product Models Include:** EX(XX)602yzzz/aaa, EX(XX)603yzzz/aaa, EX(XX)606yzzzlaaa, EX(XX)607yzzz/aaa, EX(XX)608yzzz/aaaSeries

Note: "xx" is a place holder for two numbers.

For example: EX602D01Industrial Vibration Sensor  
 These letters and numbers are included in the model numbers of the series. For details see the related data sheets.

This declaration is applicable to all Sensor(s) of the above series which have the CE & (EX) ATEX mark on their data sheets and where those data sheets refer to this declaration of conformity. The data sheets for all model numbers referenced above, which include the CE & (EX) ATEX mark on such data sheets and refer to this Declaration of Conformity are hereby incorporated by reference into this Declaration.

**Conform to the following EU Directive(s) when installed per product documentation:**

2014/30/EU  
 2014/34/EU  
 2011/65/EU w/2015/863/EU

EMC Directive  
 ATEX Directive  
 RoHS Directive

### Harmonized Standards to which Conformity is Declared:

<b>Harmonized Standards</b>	EN 61326-1:2013  EN 61326-2-3: 2013  EN 61010-1:2010 EN 61010-1:2010/A1:2019/AC:2019-04 EN 61010-1:2010/A1:2019  EN 60079-0:2018  EN 60079-11 2012  EN 63000:2018	Electrical Equipment for Measurement, Control and Laboratory Use- EMC requirements - Part 1: General requirements  Electrical equipment for measurement, control and laboratory use - EMC requirements - Part 2-3: Particular requirements - Test configuration, operational conditions and performance criteria for transducers with integrated or remote signal conditioning  Safety Requirements for Electrical Equipment for Measurement, Control, and Laboratory Use - Part 1: General Requirements  General Explosive Atmosphere  Intrinsic safe, i  Technical documentation for the assessment of electrical and electronic products with respect to the restriction of hazardous substances(IEC 63000:2016)
<b>Emissions Test Standards</b>	EN 55011:2016, EN 55011:2016/A1:2017 EN 55011:2016/A11:2020	Industrial, scientific and medical (ISM) radio frequency equipment-Electromagnetic disturbance characteristics- Limits and methods of Measurement Class B
<b>Other Standards Applied (non-OJEU)</b>	EN 61000-4-2:2009  EN 61000-4-3:2006+A2:2010	Electromagnetic compatibility (EMC)–Part 4–2: Testing and measuring techniques– Electrostatic discharge immunity test  Electromagnetic compatibility (EMC) - Part 4-3: Testing and measurement techniques - Radiated, radio-frequency, electromagnetic field immunity test

<b>Immunity Test Standards</b>	EN 61000-4-4:2012 EN 61000-4-5:2014 EN 61000-4-6:2014 EN 61000-4-8:2010	Electromagnetic compatibility (EMC) - Part 4-4: Testing and measurement techniques - Electrical fast transient/burst immunity test  Electromagnetic compatibility (EMC) - Part 4-5: Testing and measurement techniques - Surge immunity test  Electromagnetic compatibility (EMC) - Part 4-6: Testing and measurement techniques - Immunity to conducted disturbances, induced by radio-frequency fields  Electromagnetic compatibility (EMC) – Part 4-8: Testing and measurement techniques – Power frequency magnetic field immunity test
<b>Test Reports</b>	EMC Reports Safety Reports	GM29028c, GM29030c, GM29032c, GM29045c GM29029s, GM29031s, GM29033s, GM29046s
<b>EC Type Examination</b>	ATEX Certification	LCIE 06 ATEX 6033 X Ex ia IIC T4 Ga, II 1 G
<b>Voluntary Certification</b>	Voluntary Type Examination Certificate	LCIE 06 ATEX 6032 X Ex nA IC T4 Gc, II 3 G
<b>Other International Certifications</b>	IECEX Certification	IECEX LCIE 13.0045 X Ex ia IIC T4 Ga Ex nA IICT4 Gc
<b>Notified Body Name</b>		Laboratoire Central des Industries Electriques (0081)
<b>Notified Body's Address</b>		<b>FONTENAY-AUX-ROSES (Head Office)</b> 33, avenue du Général Leclerc FR- 92260 Fontenay-aux-Roses Tel. : + 33 1 40 95 60 60 Fax : + 33 1 40 95 86 56

*I, the undersigned, hereby declare that the equipment specified above conforms to the above Directive(s) Standard(s)*

**Place:** Depew, NY **Date:** 4/9/2023

Signature:



Name: Wendy Willard

Title: Regulatory Affairs and Product Certification Specialist



LCIE

1 **ATTESTATION D'EXAMEN DE TYPE VOLONTAIRE**

- 2 **Appareil** destiné à être utilisé en atmosphères explosibles (Directive 94/9/CE)
- 3 Numéro de l'attestation d'examen de type LCIE 10 ATEX 1008 X
- 4 Appareil  
Capteur de vibrations  
Type : EX686B series
- 5 Demandeur : PCB Piezotronics  
Adresse : 3425 Walden Avenue  
Depew, New York 14043 USA
- 7 Cet appareil et ses variantes éventuelles acceptées sont décrits dans l'annexe de la présente attestation et dans les documents descriptifs cités en référence.
- 8 Le LCIE certifie que cet appareil est conforme aux exigences essentielles de sécurité et de santé pour la conception d'appareils, électriques de catégorie 3 ou non électriques de catégorie 2 et 3, destinés à être utilisés en atmosphères explosibles, données dans l'annexe II de la directive 94/9/CE du Parlement européen et du Conseil du 23 mars 1994.
- Les résultats des vérifications et essais figurent dans le rapport confidentiel N° 93796/586962.
- 9 Le respect des exigences essentielles de sécurité et de santé est assuré par la conformité à :  
- EN 60079-0 (2006)  
- EN 60079-15 (2005)
- 10 Le signe X lorsqu'il est placé à la suite du numéro de l'attestation, indique que cet appareil est soumis aux conditions spéciales pour une utilisation sûre, mentionnées dans l'annexe de la présente attestation.
- 11 Cette attestation d'examen de type concerne uniquement la conception, les vérifications et essais de l'appareil de spécifié, conformément à l'annexe VIII la directive 94/9/CE. Des exigences supplémentaires de la directive sont applicables pour la fabrication et la fourniture de l'appareil. Ces dernières ne sont pas couvertes par la présente attestation.
- 12 Le marquage de l'appareil doit comporter les informations détaillées au point 15.

Fontenay-aux-Roses, le 9 août 2010

1 **VOLUNTARY TYPE EXAMINATION CERTIFICATE**

- 2 **Equipment** intended for use in potentially explosive atmospheres (Directive 94/9/EC)
- 3 Type Examination Certificate number LCIE 10 ATEX 1008 X
- 4 Equipment  
Vibration sensors  
Type : EX686B series
- 5 applicant : PCB Piezotronics  
Address : 3425 Walden Avenue  
Depew, New York 14043 USA
- 7 This equipment and any acceptable variation thereto is specified in the schedule to this certificate and the documents therein referred to.
- 8 LCIE certifies that this equipment has been found to comply with the essential Health and Safety Requirements that relate to the design of equipment, of category 3 electrical or categories 2 and 3 non electrical, which is intended for use in potentially explosive atmospheres, given in Annex II of the Directive 94/9/EC of the European Parliament and Council of 23 March 1994.
- The examination and test results are recorded in confidential report N° 93796/586962.
- 9 Compliance with the Essential Health and Safety Requirements has been assured by reference to :  
- EN 60079-0 (2006)  
- EN 60079-15 (2005)
- 10 If the sign X is placed after the certificate number, it indicates that the equipment is subject to special conditions for safe use specified in the schedule to this certificate.
- 11 This type examination certificate relates only to the design, examination and tests of this specified equipment, in accordance with annex VIII to the directive 94/9/EC. Further requirements of the Directive may apply to the manufacturing process and supply of this equipment. These are not covered by this certificate.
- 12 The marking of the equipment shall include information as detailed at 15.

Le responsable de certification ATEX  
ATEX certification manager

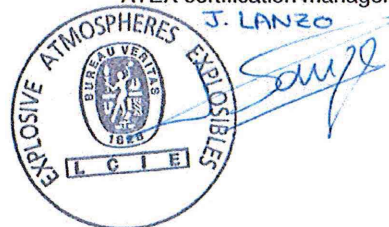

Seul le texte en français peut engager la responsabilité du LCIE. Ce document ne peut être reproduit que dans son intégralité, sans aucune modification  
The LCIE's liability applies only on the French text. This document may only be reproduced in its entirety and without any change



LCIE



13 ANNEXE

14 ATTESTATION D'EXAMEN DE TYPE VOLONTAIRE

LCIE 10 ATEX 1008 X

15 DESCRIPTION DE L'APPAREIL

Capteur de vibrations  
Type : EX686B series

Le capteur de vibrations piézo-électrique utilise un cristal pour convertir une mesure de vibration mécanique en un signal électrique.

Le capteur est en une seule partie, consistant en une enveloppe métallique étanche, contenant un ensemble piézo-cristal et un amplificateur.

Paramètres spécifiques du ou des modes de protection concernés :

12-30VDC ou 24VDC/VAC-240VDC/VAC

Le marquage doit être :

Modèles EX686Bxxxxxx :

PCB Piezotronics Adresse : ...

Type : EX686Bxxxxxx (1)

Numéro de fabrication : ...

Date de fabrication : ...

Ex II 3G

Ex nL IIC T3

LCIE 10 ATEX 1008 X

T amb : -54°C à + 85°C

(1) complété avec le modèle

Modèles EX686B7xxxxxx et

EX686Byyyyyy6 :

PCB Piezotronics Adresse : ...

Type : EX686B7xxxxxx ou EX686Byyyyyy6 (1)

Numéro de fabrication : ...

Année de fabrication : ...

Ex II 3G

Ex nA II T3

LCIE 10 ATEX 1008 X

T amb : -54°C à + 85°C

(1) complété avec le modèle

L'appareil doit également comporter le marquage normalement prévu par les normes de construction qui le concerne.

16 DOCUMENTS DESCRIPTIFS

Dossier technique n° 44999 rév.NR du 16/12/09.

Ce document comprend 8 rubriques (16 pages).

17 CONDITIONS SPECIALES POUR UNE UTILISATION SÛRE

Température ambiante d'utilisation : -54°C à +85°C.

Le matériel ne doit être raccordé qu'à un équipement dont les paramètres électriques sont compatibles aux valeurs mentionnées au paragraphe 15.

13 SCHEDULE

14 VOLUNTARY TYPE EXAMINATION CERTIFICATE

LCIE 10 ATEX 1008 X

15 DESCRIPTION OF EQUIPMENT

Vibrations sensor  
Type : EX686B series

The model piezoelectric vibration sensor utilize a crystal to convert a mechanical vibration measurement into an electric signal.

The sensor is 1-piece assembly, consisting of a sealed metal housing, containing the piezo-crystal assembly and the charge amplifier.

Specific parameters of the mode(s) of protection concerned :

12-30VDC or 24VDC/VAC-240VDC/VAC

The marking shall be :

Models EX686Bxxxxxx :

PCB Piezotronics Address : ...

Type : EX686Bxxxxxx (1)

Serial number : ...

Year of construction : ...

Ex II 3G

Ex nL IIC T3

LCIE 10 ATEX 1008 X

T amb : -54°C to + 85°C

(1) completed with the model

Models EX686B7xxxxxx and

EX686Byyyyyy6 :

PCB Piezotronics Adresse : ...

Type : EX686B7xxxxxx or EX686Byyyyyy6 (1)

Serial number : ...

Year of construction : ...

Ex II 3G

Ex nA II T3

LCIE 10 ATEX 1008 X

T amb : -54°C to + 85°C

(1) completed with the model

The equipment shall also bear the usual marking required by the manufacturing standards applying to such equipment.

16 DESCRIPTIVE DOCUMENTS

Technical file n° 44999 rev.NR dated 12/16/09.

This file includes 8 items (16 pages).

17 SPECIAL CONDITIONS FOR SAFE USE

Operating ambient temperature : -54°C to +85°C

The apparatus must be only connected to an equipment whose electrical parameters are compatible with the values mentioned clause 15.

MEg

81000



LCIE

**13 ANNEXE (suite)**

**14 ATTESTATION D'EXAMEN DE TYPE VOLONTAIRE**

LCIE 10 ATEX 1008 X

**18 EXIGENCES ESSENTIELLES DE SECURITE ET DE SANTE**

Couvertes par les normes listées au point 9.

**19 VERIFICATIONS ET ESSAIS INDIVIDUELS**

Chaque appareil doit être soumis à un essai de rigidité diélectrique pendant 1 minute sous une tension sinusoïdale de 50 Hz et d'une valeur de 1500V appliquée entre les fils de raccordement et le corps de l'appareil.

**20 CONDITIONS DE CERTIFICATION**

Les détenteurs d'attestations d'examen de type doivent également satisfaire les exigences de contrôle de production telles que définies au paragraphe 5 de l'annexe VIII de la directive 94/9/CE.

**13 SCHEDULE (continued)**

**14 VOLUNTARY TYPE EXAMINATION CERTIFICATE**

LCIE 10 ATEX 1008 X

**18 ESSENTIAL HEALTH AND SAFETY REQUIREMENTS**

Covered by standards listed at 9.

**19 ROUTINE VERIFICATIONS AND TESTS**

Each apparatus must be submitted to a dielectric strength test during 1 minute, with a sine-shaped voltage at 50 Hz of 1500 V r.m.s. between the wires of the cable and the body of the apparatus.

**20 CONDITIONS OF CERTIFICATION**

Holders of type examination certificates are also required to comply with the production control requirements defined in paragraph 5 of annex VIII of directive 94/9/EC.

641

11/18



**СЕРТИФИКАТ СООТВЕТСТВИЯ**

№ ЕАЭС RU C-US.AA87.B.00217/19

Серия **RU** № **0124866**



**ОРГАН ПО СЕРТИФИКАЦИИ** Орган по сертификации взрывозащищенного и рудничного оборудования (ОС ЦСВЭ) Общества с ограниченной ответственностью «Центр по сертификации взрывозащищенного и рудничного оборудования» (ООО «НАНИО ЦСВЭ»). Адрес места нахождения юридического лица: Россия, 140004, Московская область, Люберецкий район, город Люберцы, поселок ВУГИ, АО «Завод «ЭКОМАШ», литера В, Объект 6, этаж 3, офис 26. Адрес места осуществления деятельности в области аккредитации: Россия, 140004, Московская область, Люберецкий район, город Люберцы, поселок ВУГИ, АО «Завод «ЭКОМАШ», Литера В, Объект 6, этаж 3, офисы 26/3, 26/4, 26/5, 27/6, 30/1, 32. Аттестат № RA.RU.11AA87 от 20.07.2015 г. Телефон: +7 (495) 558-83-53, +7 (495) 558-82-44. Адрес электронной почты: ccve@ccve.ru

**ЗАЯВИТЕЛЬ** Общество с ограниченной ответственностью «Альфатех». Адрес места нахождения юридического лица: Россия, 125009, Москва, Малый Гнезниковский переулок, дом № 12, помещение I, комната 4. Адрес места осуществления деятельности: Россия, 127495, Москва, Долгопрудненское шоссе, дом № 3, Технопарк «Физтехпарк». ОГРН: 1167746393792. Телефон: +7 (495) 642-49-14. Адрес электронной почты: info@alphatechgroup.ru

**ИЗГОТОВИТЕЛЬ** PCB Piezotronics, Inc  
Адрес места нахождения юридического лица и адрес места осуществления деятельности по изготовлению продукции: 3425 Walden Av., Depew, NY 14043, США

**ПРОДУКЦИЯ** Пьезоэлектрические преобразователи, вибропереключатели, предусилители с Ex-маркировкой согласно приложению (см. бланки №№ 0621345, 0621346, 0621347). Документы, в соответствии с которыми изготовлены изделия – см. приложение, бланк № 0621344. Серийный выпуск.

КОД ТН ВЭД ЕАЭС 9031 80 3800, 9026 20 2000, 8517 69 9000

СООТВЕТСТВУЕТ ТРЕБОВАНИЯМ  
ТР ТС 012/2011 «О безопасности оборудования для работы во взрывоопасных средах».

**СЕРТИФИКАТ СООТВЕТСТВИЯ ВЫДАН НА ОСНОВАНИИ**  
Протокола испытаний № 235.2019-Т от 11.09.2019 Испытательной лаборатории технических устройств Автономной некоммерческой организации «Национальный испытательный и научно-исследовательский институт оборудования для взрывоопасных сред» ИЛ Ex TU (аттестат № РОСС RU.0001.21MШ19 от 16.10.2015); Акта анализа состояния производства № 35-А/19 от 14.03.2019 Органа по сертификации взрывозащищенного и рудничного оборудования (ОС ЦСВЭ) Общества с ограниченной ответственностью «Центр по сертификации взрывозащищенного и рудничного оборудования» (ООО «НАНИО ЦСВЭ») (аттестат № RA.RU.11AA87 выдан 20.07.2015); Документов, представленных заявителем в качестве доказательства соответствия продукции требованиям ТР ТС 012/2011 (см. приложение, бланк № 0621344).  
Схема сертификации – 1с.

**ДОПОЛНИТЕЛЬНАЯ ИНФОРМАЦИЯ**  
Перечень стандартов, применяемых на добровольной основе для соблюдения требований ТР ТС 012/2011 (см. приложение, бланк № 0621344). Условия и срок хранения указаны в эксплуатационной документации. Назначенный срок службы – 10 лет.

СРОК ДЕЙСТВИЯ С 13.09.2019 ПО 12.09.2024  
ВКЛЮЧИТЕЛЬНО

Руководитель (уполномоченное лицо) органа по сертификации

(подпись)

Залогин Александр Сергеевич

(Ф.И.О.)

Эксперт (эксперт-аудитор) (эксперты (эксперты-аудиторы))

(подпись)

М.П. Рафалович Борис Александрович

(Ф.И.О.)

ПРИЛОЖЕНИЕ

К СЕРТИФИКАТУ СООТВЕТСТВИЯ № ЕАЭС RU C-US.AA87.B.00217/19 Лист 1

Серия RU № 0621344

**I. ПЕРЕЧЕНЬ СТАНДАРТОВ, ПРИМЕНЯЕМЫХ НА ДОБРОВОЛЬНОЙ ОСНОВЕ  
ДЛЯ СОБЛЮДЕНИЯ ТРЕБОВАНИЙ ТР ТС 012/2011 «О БЕЗОПАСНОСТИ ОБОРУДОВАНИЯ  
ДЛЯ РАБОТЫ ВО ВЗРЫВООПАСНЫХ СРЕДАХ»**

Обозначение стандартов	Наименование стандартов
ГОСТ 31610.0-2014 (IEC 60079-0:2011)	Взрывоопасные среды. Часть 0. Оборудование. Общие требования
ГОСТ IEC 60079-1-2011	Взрывоопасные среды. Часть 1. Оборудование с видом взрывозащиты «взрывонепроницаемые оболочки «d»
ГОСТ 31610.11-2014 (IEC 60079-11:2011)	Взрывоопасные среды. Часть 11. Оборудование с видом взрывозащиты «искробезопасная электрическая цепь «i»
ГОСТ 31610.15-2012/МЭК 60079-15:2005	Электрооборудование для взрывоопасных газовых сред. Часть 15. Конструкция, испытания и маркировка электрооборудования с видом защиты «п»

**II. ДОКУМЕНТЫ, ПРЕДСТАВЛЕННЫЕ ЗАЯВИТЕЛЕМ В КАЧЕСТВЕ ДОКАЗАТЕЛЬСТВА  
СООТВЕТСТВИЯ ПРОДУКЦИИ ТРЕБОВАНИЯМ ТР ТС 012/2011**

Руководства по эксплуатации: № 750119 от 23.01.19, № 830119 от 23.01.19, № 940219 от 07.02.19, № 630119 от 22.01.19, № 610119 от 22.01.19, № 910219 от 07.02.19, № 950219 от 08.02.19, № 970219 от 08.02.19.  
Технические файлы: № 54202 от 02.02.2017, № 54204 от 02.02.2017, № 22438 С от 19.07.2012, № 62501 от 06.10.2016, № 33699 от 16.06.2016, № 56178 от 01.07.2016, № 70893 от 24.07.2019, № 54707 от 10.08.2016, № 48813 от 06.01.2011  
Чертежи: № 47912 от 31.03.2017, № 49038 от 31.03.2017.  
Перечень стандартов см. п. I.

**III. ДОКУМЕНТЫ, В СООТВЕТСТВИИ С КОТОРЫМИ ИЗГОТОВЛЕНА ПРОДУКЦИЯ**

Технические файлы: № 54202 от 02.02.2017, № 54204 от 02.02.2017, № 22438 С от 19.07.2012, № 62501 от 06.10.2016, № 33699 от 16.06.2016, № 56178 от 01.07.2016, № 70893 от 24.07.2019, № 54707 от 10.08.2016, № 48813 от 06.01.2011  
Чертежи: № 47912 от 31.03.2017, № 49038 от 31.03.2017

Руководитель (уполномоченное  
лицо) органа по сертификации

(подпись)

Эксперт (эксперт-аудитор)  
(эксперты (эксперты-аудиторы))

(подпись)



Залогин Александр Сергеевич  
(Ф.И.О.)

М.П.

Рафалович Борис Александрович  
(Ф.И.О.)

ПРИЛОЖЕНИЕ

К СЕРТИФИКАТУ СООТВЕТСТВИЯ № ЕАЭС RU C-US.AA87.B.00217/19 Лист 2

Серия RU № 0621345

1. НАЗНАЧЕНИЕ И ОБЛАСТЬ ПРИМЕНЕНИЯ

Пьезоэлектрические преобразователи (далее – преобразователи) предназначены для контроля параметров вибрации, динамического давления и преобразования их в электрический сигнал.

Вибропереключатели предназначены для контроля уровня вибрации и защиты оборудования от повышенной вибрации.

Предусилители предназначены для преобразования зарядового сигнала в вольтовый.

Область применения - взрывоопасные зоны помещений и наружных установок согласно Ex-маркировке, ГОСТ IEC 60079-14-2013, регламентирующих применение во взрывоопасных средах.

2. СТРУКТУРНОЕ ОБОЗНАЧЕНИЕ

2.1. Преобразователи 176ХУУ/МZZZ-АА

X = от А до Z ревизия продукта, не влияющая на взрывозащиту

УУ = от 01 до 99 для индикации вариантов монтажа, диафрагмы, кабелей или разъемов

M = опционально для указания метрической длины кабеля

ZZZ = от 001 до 999 опционально для указания длины кабеля в футах: (не более 200 футов) или метрах: (не более 61 м)

AA = от 01 до 99 опционально для указания дробной длины кабеля в дюймах или сантиметрах, не влияющей на взрывозащиту

2.2. Преобразователи 351abcd

a – ревизия продукта, может быть: А,В,С,Д,Е,F,G,H,I,J,K,L или M, не влияющая на взрывозащиту

b – первая цифра вариации продукта, может быть: 0,1,2,3,4,5,6,7,8 или 9, не влияющая на взрывозащиту

c – вторая цифра вариации продукта, может быть: 0,1,2,3,4,5,6,7,8 или 9, не влияющая на взрывозащиту

d – третья цифра вариации продукта, может быть: 0,1,2,3,4,5,6,7,8,9 или отсутствует, не влияющая на взрывозащиту

2.3 Преобразователи EX(TO)(M)602yzzz/aaa, EX(TO)(M)603yzzz/aaa, EX(TO)(M)606yzzz/aaa, EX(TO)(M)607yzzz/aaa, EX(TO)(M)608yzzz/aaa, EX(M)637XYYYZ, (M)638XYYYZ

XX = TO (с температурным выходом), M (с метрической резьбой),

y = одна буква от А до Z, не влияющая на взрывозащиту

zzz = две или три цифры от 00 до 999, не влияющие на взрывозащиту

aaa = длина кабеля и/или тип разъема

2.4 Предусилители EX682XYYY

X – ревизия продукта (А,В ... М), не влияющая на взрывозащиту

YYY: параметры фильтрации, усиления, частотная характеристика, ... (от 1 до 999), не влияющие на взрывозащиту

2.5 Преобразователи EX(RV)(TO)(M)64хухх, EX(RV)(TO)(M)649ухх, EX (RV)(TO) (M)686ухх

XX = M (с метрической резьбой), TO (с температурным выходом), RV (с доп. вольтовым выходом).

Буквы х являются переменными цифрами (значения от 0 до 9), не влияющими на взрывозащиту

y = одна буква от А до Z, не влияющая на взрывозащиту

2.6 Преобразователи EX (XX) 622yzzz / aaa, EX (XX) 623yzzz / aaa, EX (XX) 625yzzz / aaa, EX (XX) 628yzzz / aaa

XX = HT (Высокотемпературная версия), M (с метрической резьбой), TO (с температурным выходом), VO (с выходом по скорости).

y = одна буква от А до Z, не влияющая на взрывозащиту

zzz = две или три цифры от 00 до 999, не влияющие на взрывозащиту

aaa = длина кабеля и/или тип разъема

2.7 Вибропереключатели 685ухх

Буквы х являются переменными цифрами (значения от 0 до 9), не влияющими на взрывозащиту

y = одна буква от А до Z, не влияющая на взрывозащиту

Руководитель (уполномоченное лицо) органа по сертификации

(подпись)

Залогин Александр Сергеевич (Ф.И.О.)

Эксперт (эксперт-аудитор) (эксперты (эксперты-аудиторы))

(подпись)

Рафалович Борис Александрович (Ф.И.О.)



## ПРИЛОЖЕНИЕ

К СЕРТИФИКАТУ СООТВЕТСТВИЯ № ЕАЭС RU C-US.AA87.B.00217/19 Лист 3

Серия **RU** № **0621346**

### 3. ОСНОВНЫЕ ТЕХНИЧЕСКИЕ ДАННЫЕ

3.1. Ех-маркировка: преобразователей 176XYU/MZZ-AA	0Ex ia IIC T660°C...T6 Ga X
преобразователей 351abcd	0Ex ia IIC T4 Ga X
вибропереключателей 685yxx	1Ex d IIB+H <sub>2</sub> T4 Gb
преобразователей EX(TO)(M)602yzzz1aaa, EX(TO)(M)603yzzz/aaa, EX(TO)(M)606yzzz/aaa, EX(TO)(M)607yzzz/aaa, EX(TO)(M)608yzzz/aaa	2Ex nA IIC T4 Gc X или 0Ex ia IIC T4 Ga X
преобразователей EX(M)637XYUZZ, (M)638XYUZZ	0Ex ia IIC T4 Ga X или 2Ex nA IIC T4 Gc X
предусилителей EX682XYU	0Ex ia IIC T4 Ga X или 2Ex nA IIC T4 Gc X
EX(RV)(TO)(M)64хyxx, EX(RV)(TO)(M)649yxx, EX (RV)(TO) (M)686yxx	1Ex d IIC T4 Gb X или 1Ex d IIC T3 Gb X
преобразователей EX (XX) 622yzzz / aaa, EX (XX) 623yzzz / aaa, EX (XX) 625yzzz / aaa , EX (XX) 628yzzz / aaa	2Ex nA IIC T4 Gc X
3.2. Диапазон температур окружающей среды, °С, преобразователей 176XYU/MZZ-AA	от -70 до 650
преобразователей 351abcd	от -196 до 121
вибропереключателей 685yxx	от -25 до 60
преобразователей EX(TO)(M)602yzzz1aaa, EX(TO)(M)603yzzz/aaa, EX(TO)(M)606yzzz/aaa, EX(TO)(M)607yzzz/aaa, EX(TO)(M)608yzzz/aaa	от -54 до 121
преобразователей EX(M)637XYUZZ, (M)638XYUZZ	от -196 до 121
предусилителей EX682XYU	от -40 до 85
преобразователей EX(RV)(TO)(M)64хyxx, EX(RV)(TO)(M)649yxx, EX (RV)(TO) (M)686yxx	от -20 до 80
преобразователей EX (XX) 622yzzz / aaa, EX (XX) 623yzzz / aaa, EX (XX) 625yzzz / aaa , EX (XX) 628yzzz / aaa	от -54 до 121

### 3.3. Входные искробезопасные электрические параметры преобразователей, предусилителей:

Модель	U <sub>i</sub> , В	I <sub>i</sub> , мА	P <sub>i</sub> , Вт	C <sub>i</sub> , нФ	L <sub>i</sub> , мГн
преобразователей 176XYU/MZZ-AA	30	300	1	5	0,5
преобразователей 351abcd	28	200	1,2	61	305 мкГн
преобразователей EX(TO)(M)602yzzz1aaa, EX(TO)(M)603yzzz/aaa, EX(TO)(M)606yzzz/aaa, EX(TO)(M)607yzzz/aaa, EX(TO)(M)608yzzz/aaa	28	200	1	16,2 или 77,2 (с кабелем)	пренебрежимо мала или 305 мкГн (с учетом кабеля 305м)
преобразователей EX(M)637XYUZZ, (M)638XYUZZ	28	93	0,65	6,5	пренебрежимо мала
предусилителей EX682XYU	28	100	0,7	пренебрежимо мала	пренебрежимо мала

Руководитель (уполномоченное  
лицо) органа по сертификации

(подпись)

Эксперт (эксперт-аудитор)  
(эксперты (эксперты-аудиторы))

(подпись)

Залогин Александр Сергеевич

(Ф.И.О.)

М.П. Рафалович Борис Александрович

(Ф.И.О.)

## ПРИЛОЖЕНИЕ

К СЕРТИФИКАТУ СООТВЕТСТВИЯ № ЕАЭС RU C-US.AA87.B.00217/19 Лист 4

Серия **RU** № **0621347**

### 3.4. Электрические параметры:

#### 3.4.1 вибропереключателей 685ухх

Напряжение питания, В 85-245 (AC), 24 (DC)  
 Максимальный ток, mA 150

3.4.2 преобразователей EX(TO)(M)602yzzz/aaa, EX(TO)(M)603yzzz/aaa, EX(TO)(M)606yzzz/aaa, EX(TO)(M)607yzzz/aaa, EX(TO)(M)608yzzz/aaa, EX (XX) 622yzzz / aaa, EX (XX) 623yzzz / aaa, EX (XX) 625yzzz / aaa, EX (XX) 628yzzz / aaa

с Ex-маркировкой 2Ex nA IIC T4 Gc X:

Напряжение питания, В 28  
 Максимальный ток, mA 200  
 Мощность, Вт 1

#### 3.4.3 преобразователей EX(M)637XYYYZ, (M)638XYYYZ

Напряжение питания, В 18 – 28  
 Максимальный ток, mA 1,6 – 20  
 Мощность, Вт 0,5

#### 3.4.4 Предусилителей EX682XYYY

Напряжение питания, В 22 – 28  
 Максимальный ток, mA 3,1 – 4,1  
 Мощность, Вт 0,1

#### 3.4.5 преобразователей EX(RV)(TO)(M)64уххх, EX(RV)(TO)(M)649ухх, EX (RV)(TO) (M)686ухх

Напряжение питания, В 18 – 30  
 Максимальный ток, mA 1,6 – 20  
 Мощность, Вт 0,5

### 4. ОПИСАНИЕ КОНСТРУКЦИИ И СРЕДСТВ ОБЕСПЕЧЕНИЯ ВЗРЫВОЗАЩИЩЕННОСТИ

Преобразователи состоят из герметичного цилиндрического металлического корпуса, в котором размещается печатная плата и пьезокристаллический элемент. Сборка подключается к разъему или встроенному кабелю. На наружной поверхности корпуса преобразователя нанесена маркировка.

Вибропереключатели серии 685ухх выполнены в металлическом корпусе, внутри которого размещена электронная плата. На наружной поверхности корпуса нанесена маркировка.

Предусилители серии EX682XYYY выполнены в прямоугольном пластиковом корпусе с креплением на DIN рейку. Внутри корпуса размещена электронная плата. На корпусе размещен съемный клеммный блок. На наружной поверхности корпуса нанесена маркировка.

Подробное описание конструкции приведено в Руководствах по эксплуатации №750119 от 23.01.19, №830119 от 23.01.19, №940219 от 07.02.19, №630119 от 22.01.19, №610119 от 22.01.19, №910219 от 07.02.19, №950219 от 08.02.19, №970219 от 08.02.19

Взрывозащищенность преобразователей, вибропереключателей и предусилителей обеспечивается выполнением требований: ГОСТ 31610.15-2012/МЭК 60079-15:2005, ГОСТ 31610.0-2014 (IEC 60079-0:2011), ГОСТ IEC 60079-1-2011, ГОСТ 31610.11-2014 (IEC 60079-11:2011), в соответствии с Ex-маркировкой.

### 5. МАРКИРОВКА

Маркировка, наносимая на преобразователи, вибропереключатели и предусилители, включает следующие данные:

- товарный знак или наименование предприятия-изготовителя;
- серийный номер или номер партии;
- диапазон значений температур окружающей среды при эксплуатации;
- Ex-маркировку;
- специальный знак взрывобезопасности;
- наименование центра по сертификации и номер сертификата;
- предупредительные надписи;
- искробезопасные параметры

и другие данные, которые изготовитель должен отразить в маркировке, в соответствии с требованиями нормативной и технической документации.

### 6. СПЕЦИАЛЬНЫЕ УСЛОВИЯ ПРИМЕНЕНИЯ

5.1 Знак X, стоящий после Ex-маркировки, означает, что при эксплуатации преобразователей, вибропереключателей, предусилителей необходимо соблюдать следующие специальные условия:

- преобразователи, вибропереключатели, предусилители должны быть подключены к сертифицированному на соответствие требованиям ТР ТС 012/2011 источнику питания с соответствующей областью применения.

5.2 Свободные концы постоянно подсоединенного кабеля должны подключаться в сертифицированной на соответствие требованиям ТР ТС 012/2011 соединительной коробке или вне взрывоопасной зоны.

Специальные условия применения, обозначенные знаком X, отражены в сопроводительной документации, подлежащей обязательной поставке в комплекте с каждым изделием.

Внесение изменений в конструкцию изделий возможно только по согласованию с ОС ЦСВЭ в соответствии с требованиями ТР ТС 012/2011.

Руководитель (уполномоченное  
лицо) органа по сертификации

Эксперт (эксперт-аудитор)  
(эксперты (эксперты-аудиторы))

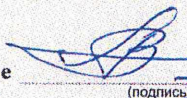
  
(подпись)

(подпись)

(подпись)



Залогин Александр Сергеевич

(ф.и.о.)

М.П. Рафалович Борис Александрович

(ф.и.о.)



# Certificate of Compliance

Certificate: 2033214

Master Contract: 184981

Project: 80020282

Date Issued: 2019-12-19

Issued To: PCB Piezotronics  
3425 Walden Ave  
Depew, New York, 14043  
United States

Attention: Carrie Termin

*The products listed below are eligible to bear the CSA Mark shown with adjacent indicators 'C' and 'US' for Canada and US or with adjacent indicator 'US' for US only or without either indicator for Canada only.*



Issued by: *Thong Tong*  
Thong Tong

## PRODUCTS

CLASS - C225803 - PROCESS CONTROL EQUIPMENT - Intrinsically Safe and Non Incendive Systems - For Hazardous Locations

CLASS - C225883 - PROCESS CONTROL EQUIPMENT-Intrinsically Safe and Non-Incendive Systems-For Hazardous Locations-Certified to U.S. Standards

Ex nL IIC T3:

AEx nA IIC T3:

Class I, Div. 2, Groups A, B, C, D:

Models EX686X0x Vibration Sensors, input rated 12-30 Vdc max, 1 mA consumption, 100 mA max. flow-through; non-incendive with entity parameters of:  $U_i$  (V max) = 30V,  $I_i$  (I max) = 100mA,  $P_i$  (Pmax) = 1W,  $C_i$  = 0,  $L_i$  = 28 uH; when installed per installation Dwg 39483; Temp Code T3 @ Max Ambient 85 Deg C.

Models EX686X1y and EX686X6y Vibration Sensors, input rated 12-30 Vdc max, 1 mA consumption, 100 mA max. flow-through; non-incendive with entity parameters of:  $U_i$  (V max) = 30V,  $I_i$  (I max) = 100mA,  $P_i$  (Pmax)



**Certificate:** 2033214  
**Project:** 80020282

**Master Contract:** 184981  
**Date Issued:** 2019-12-19

= 1W, Ci = 61 nF, Li = 333  $\mu$ H; when installed per installation Dwg 39483; Temp Code T3 @ Max Ambient 85 Deg C.

**Notes:**

1. For Canadian Installations, sensor case must be bonded to ground according to Section 18 of the CEC, Part 1.
2. For US Installations, sensor case must be bonded to ground according to Articles 501 and 505 of the NEC.
3. Letter X following product identifier number EX686 may be a capital letter from B to Z denoting Model revision level for minor revisions restricted to changes of values of capacitors and resistors within the approval limits specified on control drawing 39481 page 1 and 2. The "x" or "y" in the model code may be a number from 0 thru 9 which denotes variations in frequency response, sensitivity, and mounting configuration of the sensors.
4. An alphanumeric code (-XXXXX) following the Model Number indicates cable length and termination. Cable length not to exceed 304.5m (999ft).

**CLASS 2258 02 - PROCESS CONTROL EQUIPMENT - For Hazardous Locations**

**CLASS 2258 82 - PROCESS CONTROL EQUIPMENT - For Hazardous Locations - CERTIFIED TO U.S. STANDARDS**

4.

Ex nA IICT3:

AEx nA IIC T3:

Class I, Div. 2, Groups A, B, C, D:

Models EX686X7x Vibration Sensors, input rated 24-240 Vdc, 1 mA consumption, 500 mA max. flow-through; 24-240 Vac, 50/60 Hz, 1 mA consumption, 500 mA max. flow-through; suitable for use in Class I, Div. 2 or Class I, Zone 2 locations, when installed per installation Dwg 39486; Temp Code T3 @ Max Ambient 85 Deg C.

Models EX686Xyyyyyy6 Vibration Sensors, input rated 24-240 Vdc, 1 mA consumption, 500 mA max. flow-through; 24-240 Vac, 50/60 Hz, 1 mA consumption, 500 mA max. flow-through; suitable for use in Class I, Div. 2 or Class I, Zone 2 locations, when installed per installation Dwg 39486; Temp Code T3 @ Max Ambient 85 Deg C.

**Notes:**

1. Sensor must be installed in a suitable enclosure, acceptable to the local inspection authority having jurisdiction.
2. Letter X following product identifier number EX686 may be a capital letter from B to Z denoting Model revision level for minor revisions restricted to changes of values of capacitors and resistors within the approval limits specified on control drawing 39481 page 1 and 2. The "x" in the model code may be a number from 0 thru 9 which denotes variations in frequency response, sensitivity, and mounting configuration of the sensors.



**Certificate:** 2033214  
**Project:** 80020282

**Master Contract:** 184981  
**Date Issued:** 2019-12-19

3. An alphanumeric code (-XXXXX) following the Model Number indicates cable length and termination. Cable length not to exceed 304.5m (999ft).
4. The “yyyyy” in the model code may be a number from 0 thru 9 which denotes variations in frequency response, sensitivity, and mounting configuration of the sensors.

### APPLICABLE REQUIREMENTS

CAN/CSA-C22.2 No. 0-M91	- General Requirements – Canadian Electrical Code, Part II
C22.2 No. 142-M1987	- Process Control Equipment
C22.2 No. 213-M1987	- Non-Incendive Electrical Equipment for Use in Class I, Division 2 Hazardous Locations
UL 916 (3 <sup>rd</sup> Ed.)	- Energy Management Equipment
UL 1604 (3 <sup>rd</sup> Ed.)	- Electrical Equipment for Use in Class I and II, Division 2; Class III Hazardous (Classified) Locations
ANSI/ISA 12.12.01-2007	- Nonincendive Electrical Equipment for Use in Class I and II, Division 2 and Class III, Divisions 1 and 2 Hazardous (Classified) Locations
CAN/CSA-E60079-15:02	- Electrical apparatus for explosive gas atmospheres - Part 15: Type of Protection "n"
ANSI/UL 60079-15:02	- Electrical apparatus for Explosive Gas Atmospheres - Part 15: Type of Protection “n”

### MARKINGS

The manufacturer is required to apply the following markings:

- Products shall be marked with the markings specified by the particular product standard.
- Products certified for Canada shall have all Caution and Warning markings in both English and French.

Additional bilingual markings not covered by the product standard(s) may be required by the Authorities Having Jurisdiction. It is the responsibility of the manufacturer to provide and apply these additional markings, where applicable, in accordance with the requirements of those authorities.

The products listed are eligible to bear the CSA Mark shown with adjacent indicators 'C' and 'US' for Canada and US (indicating that products have been manufactured to the requirements of both Canadian and U.S. Standards) or with adjacent indicator 'US' for US only or without either indicator for Canada only.

Markings are etched directly into the Sensor enclosure body. The following marking details appear:

#### Div. 2 Non-Incendive models

- CSA Monogram with C US indicator.



**Certificate:** 2033214  
**Project:** 80020282

**Master Contract:** 184981  
**Date Issued:** 2019-12-19

- Submitter Identification
- Model Number
- Serial Number, Date Code or Month and Year of Manufacture
- Electrical Rating
- Hazardous Location Designation (ie Ex nL IICT4, AEx nA IICT4, Class I, Div. 2, Groups A, B, C and D)  
(In addition to these required markings, the following optional markings may also appear: Class I, Zone 2, Group IIC, T4)
- Certificate # reference (ie. 2008 2033214)
- "WARNING – EXPLOSION HAZARD. DO NOT CONNECT OR DISCONNECT WHEN ENERGIZED." or equivalent.
- "AVERTISSEMENT – RISQUE D'EXPLOSION. NE PAS BRANCHER NI DÉBRANCHER SOUS TENSION." or equivalent.

Div. 2 Non-arcing models (.....X7x)

- CSA Monogram with C US indicator.
- Submitter Identification
- Model Number
- Serial Number, Date Code or Month and Year of Manufacture
- Electrical Rating
- Hazardous Location Designation (ie Ex nA IIC T3, AExnA IICT3, Class I, Div. 2, Groups A, B, C and D)  
(In addition to these required markings, the following optional markings may also appear: Class I, Zone 2, Group IIC, T3)
- Certificate # reference (ie. 2008 2033214 X)
- "WARNING – EXPLOSION HAZARD. DO NOT CONNECT OR DISCONNECT WHEN ENERGIZED." or equivalent.
- "AVERTISSEMENT – RISQUE D'EXPLOSION. NE PAS BRANCHER NI DÉBRANCHER SOUS TENSION." or equivalent.

**ALTERATIONS**

1. Markings as above appear.
2. Internal wiring is rated for temperatures of 200 Deg. C.



## *Supplement to Certificate of Compliance*

Certificate: 2033214

Master Contract: 184981

*The products listed, including the latest revision described below,  
are eligible to be marked in accordance with the referenced Certificate.*

### Product Certification History

---

Project	Date	Description
80020282	2019-12-19	Update to CSA report 2033214 to change Model EX686B to EX686X to allow minor modifications.
0002033214	2008-09-25	Model EX686B Series Vibration sensors for Class I, Div. 2, and Zone 2 hazardous locations - North America



# Certificado de Conformidade

*Certificate of Compliance* ♦ *Certificado de Conformidad*

Certificado nº: **TÜV 12.2154**

*Certificate / Certificado nº*

Revisão: **01**

*Review/Revisión*

Válido até: **26/02/2019**

*Valid Until / Válido Hasta*

Emitido em **26/02/2016**

*Issued / Emitido*

**Produto:**

*Product/Producto:*

**SENSOR DE VIBRAÇÃO**

**Serie EX 686B**

**Marca:**

*Mark/Marca:*

**PCB**

**Solicitante:**

*Applicant/Solicitante:*

**PCB Piezotronics Inc.**

**3425 Walden Avenue**

**14043 – Depew, NY - USA**

**Fabricante:**

*Manufacturer/Fabricante:*

**PCB Piezotronics Inc.**

**3425 Walden Avenue**

**14043 – Depew, NY - USA**

**Fornecedor / Representante Legal:**

*Supplier/Legal Representative/Proveedor/  
Representante Legal:*

**Não aplicável.**

**Normas Técnicas / Regulamento:**

*Standards/Regulation/Normas/Reglamento:*

**ABNT NBR IEC 60079-0:2008;**

**ABNT NBR IEC 60079-11:2009;**

**Portaria INMETRO nº 179 de 18/05/2010.**

**Esquema de certificação:**

*Certification Scheme/Esquema de certificación*

**Modelo com Avaliação do Sistema de Gestão da Qualidade do**

**Fabricante e Ensaio no Produto, conforme cláusula 6.1 do**

**Regulamento de Avaliação da Conformidade, anexo à Portaria nº 179**

**do INMETRO, publicada em 18 de maio de 2010.**

**Laboratório, Nº do relatório de ensaios e data:**

*Laboratory and test report Nº / date /  
Laboratorio y Informe de Prueba nº / fecha:*

**LCIE – Laboratoire Central des Industries Electriques.**

**LCIE nº 93796/586962 de 30/07/2010**

**Relatório de Auditoria e data:**

*Audit Report/ data/ Informe de Auditoria/ fecha:*

**Auditoria realizada em 14/04/2016**

**Notas:**

*Notes/Anotación:*

**“A validade deste Certificado de Conformidade está atrelada à realização das avaliações de manutenção e tratamento de possíveis não conformidades de acordo com as orientações do OCP previstas no RAC específico. Para verificação da condição atualizada de regularidade deste Certificado de Conformidade deve ser consultado o banco de dados de produtos e serviços certificados do Inmetro”.**

**Este certificado está vinculado à proposta 0400112.0 de 21/11/2012.**

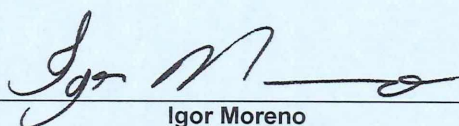

**Igor Moreno**  
**Gerente de Certificação**

*Certification Manager / Gerente de Certificación*

**“Este documento é composto de 03 páginas e é válido quando exibido com todas as suas páginas. Demais informações e notas estão contidas nas páginas subsequentes.”**





# Certificado de Conformidade

Certificate of Compliance • Certificado de Conformidad

Certificado nº: **TÜV 12.2154**

Certificate / Certificado nº

Revisão: **01**

Review/Revisión

Válido até: **26/02/2019**

Valid Until / Válido Hasta

Emitido em **26/02/2016**

Issued / Emitido

## Especificações:

O sensor de vibração modelo Ex 686B utiliza um cristal para converter a medição de vibração mecânica em um sinal elétrico.

O sensor é consiste de um invólucro metálico selado, no interior do invólucro está localizado o conjunto do cristal-piezo e o amplificador.

## Característica elétrica:

Tensão: 12-30 Vcc  
24-240 Vca

## Análise e ensaios realizados:

As análises e os ensaios realizados encontram-se no relatório técnico nº TÜV 12.2154.

## Documentação descritiva do produto:

– Relatório de ensaios nº 93796/586962 de 30/07/2010;

Documento	Páginas	Descrição	Rev.	Data
40112	36	Operating Guide with Enclosed Warranty Information	C	-
54943-1	1	Approval Assembly models EX686B7X & EX686BXXXXXX6	0	-
54943-2	1	Etching Drawing Models EX686B7X & EX686BXXXXXX6	0	-
54944-1	1	Approval Assembly Model EX686BXXXXXXX	0	-
54944-2	1	Etching Drawing Models EX686BXXXXXXX	0	-
44170-1	1	Approval Assembly Model EX686BXXXXXXX	0	10/06/2009
44170-2	1	Etching Drawing Models EX686BXXXXXXX	0	10/06/2009
44171-1	1	Approval Assembly models EX686B7X & EX686BXXXXXX6	0	10/06/2009
44171-2	1	Etching Drawing Models EX686B7X & EX686BXXXXXX6	0	10/06/2009
44999	2	Technical File	0	-
45000	1	Descriptive Notice	0	-
39481	5	Approval Electrical Assembly and Schematic	0	25/09/2008
39482	2	Approval PC Board Assembly	0	25/09/2008
41229	1	Approval Radiator Drawing	0	-
39484	1	BI-Morph Sensor Assembly	0	25/09/2008



# Certificado de Conformidade

*Certificate of Compliance • Certificado de Conformidad*

Certificado nº: **TÜV 12.2154**

*Certificate / Certificado nº*

Revisão: **01**

*Review/Revisión*

Válido até: **26/02/2019**

*Valid Until / Válido Hasta*

Emitido em **26/02/2016**

*Issued / Emitido*

## Marcação:

Os sensores de vibração modelos EX 686B foram aprovados nos ensaios e análises, nos termos das normas adotadas, devendo receber a marcação, levando-se em consideração o item observações.

**Ex ic IIC T3 Gc**  
**-54 °C ≤ T<sub>a</sub> ≤ +85 °C**

## Observações:

1. Este certificado de conformidade é válido para os produtos de modelo e tipo idêntico ao protótipo ensaiado. Qualquer modificação de projeto ou utilização de componentes e materiais diferentes daqueles descritos na documentação deste processo, sem autorização prévia da TÜV Rheinland, invalidará o certificado.
2. É responsabilidade do fabricante assegurar que os produtos fabricados estejam de acordo com as especificações do protótipo ensaiado, através de inspeções visuais e dimensionais.
3. Os produtos devem ostentar, na sua superfície externa e em local visível, a Marca de Conformidade e as características técnicas da mesma de acordo com as especificações da ABNT NBR IEC 60079-0 / ABNT NBR IEC 60079-1 / ABNT NBR IEC 60079-11 e Regulamento de Avaliação da Conformidade, anexo à Portaria nº. 179 do INMETRO, publicada em 18 de Maio de 2010. Esta marcação deve ser legível e durável, levando-se em conta possível corrosão química.
4. As atividades de instalação, inspeção, manutenção, reparo, revisão e recuperação dos produtos são de responsabilidade do usuário e devem ser executadas de acordo com os requisitos das normas técnicas vigentes e com as recomendações do fabricante.

## Natureza das revisões/Data

*Nature of Reviews/Date*

*Naturaleza de las revisiones/Fecha*

Revisão 00:

**26/02/2013 – Certificação Inicial;**

Revisão 01:

**07/06/2016 – Revalidação.**



# Certificado de Conformidade

*Certificate of Compliance + Certificado de Conformidad*

**Certificado nº: TÜV 12.2154**

*Certificate #/Certificado nº*

**Válido até: 26/02/2016**

*Validity Term/Fecha de Vencimiento*

**Produto:**  
*Product/Producto*

**SENSOR DE VIBRAÇÃO**

**Tipo / Modelo:**  
*Type - Model/Tipo - Modelo*

**SERIE EX 686B**

**Solicitante:**  
*Applicant/Solicitante*

**PCB Piezotronics Inc.  
3425 Walden Avenue  
14043 – Depew, NY - USA**

**Fabricante:**  
*Manufacturer/Fabricante*

**PCB Piezotronics Inc.  
3425 Walden Avenue  
14043 – Depew, NY - USA**

**Normas Técnicas:**  
*Standards/Normas*

**ABNT NBR IEC 60079-0:2008, ABNT NBR IEC 60079-11:2009**

**Laboratório de Ensaio:**  
*Testing Laboratory/Laboratorio de Ensayo*

**LCIE – Laboratoire Central des Industries Electriques**

**Nº do Relatório de Ensaio:**  
*Test Report Number/Nº del informe de Ensayo*

**LCIE nº 93796/586962 de 30/07/2010**

**Observações:**  
*Notes/Observaciones*

**Certificado emitido com base no Modelo com Avaliação do Sistema de Gestão da Qualidade do Fabricante e Ensaio no Produto, conforme cláusula 6.1 do Regulamento de Avaliação da Conformidade, anexo à Portaria nº 179 do INMETRO, publicada em 18 de Maio de 2010**

**Portaria:**  
*Governmental Regulation/Regulación Oficial*

**INMETRO nº 179 de 18/05/2010**

**Data de Emissão:**  
*Date of issue/Fecha de Otorgamiento*

**São Paulo, 27 de Fevereiro de 2013.**

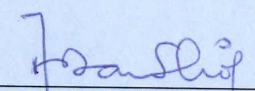
  
\_\_\_\_\_  
**Arnaldo Barbulio Filho**  
Executivo Sênior  
*Senior Executive/ Ejecutivo Senior*

  
\_\_\_\_\_  
**Igor Moreno**  
Gerente de Certificação  
*Certification Manager /Gerente de Certificación*



# Certificado de Conformidade

Certificate of Compliance + Certificado de Conformidad

Certificado nº: **TÜV 12.2154**

Certificate #/Certificado nº

Válido até: **26/02/2016**

Validity Term/Fecha de Vencimiento

## Especificações:

O sensor de vibração modelo Ex 686B utiliza um cristal para converter a medição de vibração mecânica em um sinal elétrico.

O sensor é composto de um invólucro metálico selado, no interior do invólucro está localizado o conjunto do cristal-piezo e o amplificador.

## Característica elétrica:

Tensão: 12-30 Vcc  
24-240 Vca

## Análise e ensaios realizados:

As análises e os ensaios realizados encontram-se no relatório técnico nº TÜV 12.2154.

## Documentação descritiva do produto:

– Relatório de ensaios nº 93796/586962 de 30/07/2010;

Documento	Páginas	Descrição	Rev.	Data
40112	36	Operating Guide with Enclosed Warranty Information	C	-
54943-1	1	Approval Assembly models EX686B7X & EX686BXXXXXX6	0	-
54943-2	1	Etching Drawing Models EX686B7X & EX686BXXXXXX6	0	-
54944-1	1	Approval Assembly Model EX686BXXXXXX	0	-
54944-2	1	Etching Drawing Models EX686BXXXXXX	0	-
44170-1	1	Approval Assembly Model EX686BXXXXXX	0	10/06/2009
44170-2	1	Etching Drawing Models EX686BXXXXXX	0	10/06/2009
44171-1	1	Approval Assembly models EX686B7X & EX686BXXXXXX6	0	10/06/2009
44171-2	1	Etching Drawing Models EX686B7X & EX686BXXXXXX6	0	10/06/2009
44999	2	Technical File	0	-
45000	1	Descriptive Notice	0	-
39481	5	Approval Electrical Assembly and Schematic	0	25/09/2008
39482	2	Approval PC Board Assembly	0	25/09/2008
41229	1	Approval Radiator Drawing	0	-
39484	1	BI-Morph Sensor Assembly	0	25/09/2008



# Certificado de Conformidade

*Certificate of Compliance ♦ Certificado de Conformidad*

**Certificado nº: TÜV 12.2154**

*Certificate #/Certificado nº*

**Válido até: 26/02/2016**

*Validity Term/Fecha de Vencimiento*

## Marcação:

Os sensores de vibração modelos EX 686B foram aprovados nos ensaios e análises, nos termos das normas adotadas, devendo receber a marcação, levando-se em consideração o item observações.

**Ex ic IIC T3 Gc**  
**-54 °C ≤ T<sub>a</sub> ≤ +85 °C**

## Observações:

1. Este certificado de conformidade é válido para os produtos de modelo e tipo idêntico ao protótipo ensaiado. Qualquer modificação de projeto ou utilização de componentes e materiais diferentes daqueles descritos na documentação deste processo, sem autorização prévia da TÜV Rheinland, invalidará o certificado.
2. É responsabilidade do fabricante assegurar que os produtos fabricados estejam de acordo com as especificações do protótipo ensaiado, através de inspeções visuais e dimensionais.
3. Os produtos devem ostentar, na sua superfície externa e em local visível, a Marca de Conformidade e as características técnicas da mesma de acordo com as especificações da ABNT NBR IEC 60079-0 / ABNT NBR IEC 60079-1 / ABNT NBR IEC 60079-11 e Regulamento de Avaliação da Conformidade, anexo à Portaria nº. 179 do INMETRO, publicada em 18 de Maio de 2010. Esta marcação deve ser legível e durável, levando-se em conta possível corrosão química.
4. As atividades de instalação, inspeção, manutenção, reparo, revisão e recuperação dos produtos são de responsabilidade do usuário e devem ser executadas de acordo com os requisitos das normas técnicas vigentes e com as recomendações do fabricante.

## Histórico:

26/02/2013 – Certificação Inicial – Efetivação;