



**Model M118A07**  
**Charge Output Pressure Sensor**  
**Installation and Operating Manual**

**For assistance with the operation of this product,  
contact PCB Piezotronics, Inc.**

**Toll-free: 800-828-8840**  
**24-hour SensorLine: 716-684-0001**  
**Fax: 716-684-0987**  
**E-mail: [info@pcb.com](mailto:info@pcb.com)**  
**Web: [www.pcb.com](http://www.pcb.com)**



## Repair and Maintenance

PCB guarantees Total Customer Satisfaction through its “Lifetime Warranty Plus” on all Platinum Stock Products sold by PCB and through its limited warranties on all other PCB Stock, Standard and Special products. Due to the sophisticated nature of our sensors and associated instrumentation, **field servicing and repair is not recommended and, if attempted, will void the factory warranty.**

Beyond routine calibration and battery replacements where applicable, our products require no user maintenance. Clean electrical connectors, housings, and mounting surfaces with solutions and techniques that will not harm the material of construction. Observe caution when using liquids near devices that are not hermetically sealed. Such devices should only be wiped with a dampened cloth—never saturated or submerged.

In the event that equipment becomes damaged or ceases to operate, our Application Engineers are here to support your troubleshooting efforts 24 hours a day, 7 days a week. Call or email with model and serial number as well as a brief description of the problem.

## Calibration

Routine calibration of sensors and associated instrumentation is necessary to maintain measurement accuracy. We recommend calibrating on an annual basis, after exposure to any extreme environmental influence, or prior to any critical test.

PCB Piezotronics is an ISO-9001 certified company whose calibration services are accredited by A2LA to ISO/IEC 17025, with full traceability to SI through N.I.S.T. In addition to our standard calibration services, we also offer specialized tests, including: sensitivity at elevated or cryogenic temperatures, phase response, extended high or low frequency response, extended range, leak testing, hydrostatic pressure testing, and others. For more information, contact your local PCB Piezotronics distributor, sales representative, or factory customer service representative.

## Returning Equipment

If factory repair is required, our representatives will provide you with a Return Material Authorization (RMA) number, which we use to reference any information you have already provided and expedite the repair process. This number should be clearly marked on the outside of all returned package(s) and on any packing list(s) accompanying the shipment.

## Contact Information

PCB Piezotronics, Inc.  
3425 Walden Ave.  
Depew, NY14043 USA  
Toll-free: (800) 828-8840  
24-hour SensorLine: (716) 684-0001  
General inquiries: [info@pcb.com](mailto:info@pcb.com)  
Repair inquiries: [rma@pcb.com](mailto:rma@pcb.com)

For a complete list of distributors, global offices and sales representatives, visit our website, [www.pcb.com](http://www.pcb.com).

## Safety Considerations

This product is intended for use by qualified personnel who recognize shock hazards and are familiar with the precautions required to avoid injury. While our equipment is designed with user safety in mind, the protection provided by the equipment may be impaired if equipment is used in a manner not specified by this manual.

Discontinue use and contact our 24-Hour Sensorline if:

- Assistance is needed to safely operate equipment
- Damage is visible or suspected
- Equipment fails or malfunctions

For complete equipment ratings, refer to the enclosed specification sheet for your product.

## Definition of Terms and Symbols

The following symbols may be used in this manual:



### DANGER

Indicates an immediate hazardous situation, which, if not avoided, may result in death or serious injury.

**CAUTION**

Refers to hazards that could damage the instrument.

**NOTE**

Indicates tips, recommendations and important information. The notes simplify processes and contain additional information on particular operating steps.

**The following symbols may be found on the equipment described in this manual:**



This symbol on the unit indicates that high voltage may be present. Use standard safety precautions to avoid personal contact with this voltage.



This symbol on the unit indicates that the user should refer to the operating instructions located in the manual.



This symbol indicates safety, earth ground.



PCB工业监视和测量设备 - 中国RoHS2公布表

PCB Industrial Monitoring and Measuring Equipment - China RoHS 2 Disclosure Table

部件名称	有害物质					
	铅 (Pb)	汞 (Hg)	镉 (Cd)	六价铬 (Cr(VI))	多溴联苯 (PBB)	多溴二苯醚 (PBDE)
住房	0	0	0	0	0	0
PCB板	X	0	0	0	0	0
电气连接器	0	0	0	0	0	0
压电晶体	X	0	0	0	0	0
环氧	0	0	0	0	0	0
铁氟龙	0	0	0	0	0	0
电子	0	0	0	0	0	0
厚膜基板	0	0	X	0	0	0
电线	0	0	0	0	0	0
电缆	X	0	0	0	0	0
塑料	0	0	0	0	0	0
焊接	X	0	0	0	0	0
铜合金/黄铜	X	0	0	0	0	0
本表格依据 SJ/T 11364 的规定编制。						
0：表示该有害物质在该部件所有均质材料中的含量均在 GB/T 26572 规定的限量要求以下。						
X：表示该有害物质至少在该部件的某一均质材料中的含量超出 GB/T 26572 规定的限量要求。						
铅是欧洲RoHS指令2011/65/ EU附件三和附件四目前由于允许的豁免。						

CHINA RoHS COMPLIANCE

Component Name	Hazardous Substances					
	Lead (Pb)	Mercury (Hg)	Cadmium (Cd)	Chromium VI Compounds (Cr(VI))	Polybrominated Biphenyls (PBB)	Polybrominated Diphenyl Ethers (PBDE)
Housing	O	O	O	O	O	O
PCB Board	X	O	O	O	O	O
Electrical Connectors	O	O	O	O	O	O
Piezoelectric Crystals	X	O	O	O	O	O
Epoxy	O	O	O	O	O	O
Teflon	O	O	O	O	O	O
Electronics	O	O	O	O	O	O
Thick Film Substrate	O	O	X	O	O	O
Wires	O	O	O	O	O	O
Cables	X	O	O	O	O	O
Plastic	O	O	O	O	O	O
Solder	X	O	O	O	O	O
Copper Alloy/Brass	X	O	O	O	O	O

This table is prepared in accordance with the provisions of SJ/T 11364.

O: Indicates that said hazardous substance contained in all of the homogeneous materials for this part is below the limit requirement of GB/T 26572.

X: Indicates that said hazardous substance contained in at least one of the homogeneous materials for this part is above the limit requirement of GB/T 26572.

Lead is present due to allowed exemption in Annex III or Annex IV of the European RoHS Directive 2011/65/EU.

## 1.0 INTRODUCTION

The Model 165B02 & 118A07 are, charge mode ballistics transducers with welded diaphragm and a rugged quartz element of proven reliability ideally suited for shotgun shells. The transducer's welded diaphragm provides better transient thermal characteristics, important for ballistics applications. The rugged piezoelectric element utilizes synthetic quartz crystals to convert instantaneous pressure changes to an analogous electrostatic charge. Chamber pressure is sensed by the transducer as the round is fired.

The transducer also serves as a replacement for other diaphragm-type gauges. In addition to ballistics testing, the Model 165B02 & 118A07 can be used for hydraulic and pneumatic test applications.

## 2.0 DESCRIPTION

Figure 2.1 shows the external configuration of the Model 165B02. The unit is housed in a lightweight stainless steel case and has a stainless steel diaphragm. It comfortably tolerates ambient temperatures ranging from -400 to +400 °F (-240 to +204 °C).

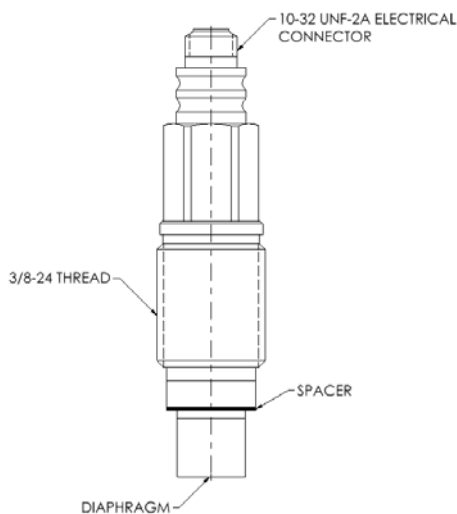

FIGURE 2.1 MODEL 165B02 & 118A07  
EXTERNAL CONFIGURATION  
(M10X1 FOR METRIC)

The 3/8-24 thread and flush diaphragm design are conventional, providing direct interchangeability with existing machined diaphragm-type piezoelectric transducers. The short, rigid quartz element and stiff diaphragm give the unit a 250 kHz natural frequency and good linearity, even below 1 000 psi.

Drawing Number: 21109  
Revision: NR

## 3.0 INSTALLATION

When choosing an installation method, the advantages and disadvantages of each method must be carefully weighed. Characteristics like location, ruggedness, amplitude range, accessibility, temperature and portability may be greatly affected by the installation configuration and technique. Often, the most important and overlooked consideration is the affect the mounting technique has on the high-frequency operating range of the pressure sensor.

Two basic mounting techniques are recommended for pressure sensors: the recess mount and the flush mount. The technique used is determined by the specifics of the individual application. See the Installation Drawing in this manual for additional details on the individual sensor series.

A torque wrench should be used to ensure specified mounting torque when installing the unit. Refer to the Installation Drawing, located in the Appendix, for the recommended torque value.

It is wise to replace the seal each time the transducer is installed. One is supplied with the sensor; replacements are available as regular stock items.

### 3.1 Mounting in Existing Recessed Ports

The Model 165B02 & 118A07 mounts directly in existing ports machined for PCB Models 165A02, 167A, 167A02, 167A11, 167A12, and others.

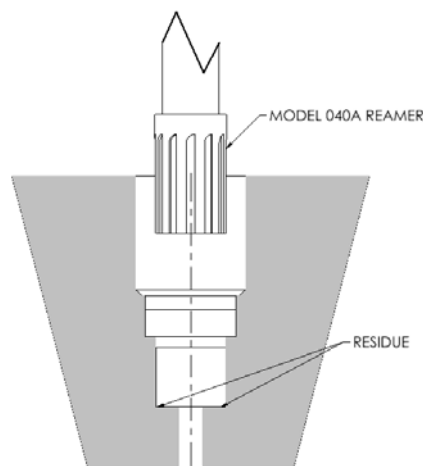

FIGURE 3.1 RESIDUE REMOVAL

Before installing the transducer in previously used mounting ports, clean out the residue remaining from previous tests as shown in Figure 3.1 . This is accomplished by hand-reaming the 1/4-inch diameter hole, using a PCB Model 040B20 (English Port, Drawing 42831) or 040B21 (Metric Port, Drawing 42832) Flat-Bottom Reamer or its equivalent.

It is important to note that the seal surface may require remachining to get it sufficiently clean following prolonged use. If this procedure is necessary, do not forge too deeply into the 1/4-inch (6.35 mm) diameter hole. Doing so could remove the shoulder, causing the transducer to bottom out when it is installed.

If waveform distortion occurs during prolonged testing, remove the transducer and clean out the residue as shown on 42831, & 42832.

### 3.2 Preparing New Mounting Ports

Refer to drawings 42831, & 42832 provided for instructions on mounting hole preparation. For best results, do not deviate from the outlined steps.

Use good machining practice in preparing the mounting port. Pay particular attention to the seal surface (.323 inches / 8.2 mm in diameter), keeping it free from tool chatter marks.

**NOTE:** It is important that this surface be perfectly smooth and free from nicks or other discontinuities that could cause leaks at high pressures.

### 3.3 Recess Mount

The recess mount technique protects the sensor diaphragm from the effect of high flash temperature and particle impingement. This method is often selected because it can prolong sensor life and increase data integrity by reducing thermal error. See Figure 3.2.

The recommended range of passage diameters is .090 to .125 inches (2.286 to 3.175 mm) in diameter.

When using the recess mount technique, note that the length of the passage may limit the usable frequency range of the sensor. The effect the passage has is like that of an under-damped second order system, with the resonant frequency determined by passage length. The passage length thus limits the pressure pulse rise time and may also cause passage ringing.

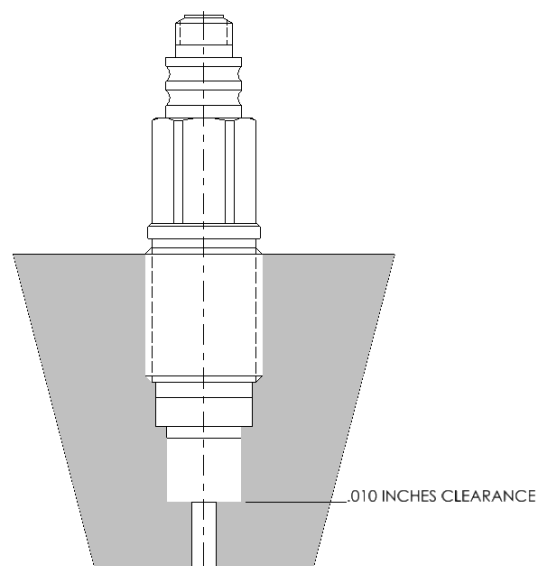

**FIGURE 3.2 RECESS MOUNT**

The function is described by the following equation:

$$F_r = \frac{V}{4L}$$

Where:  $F_r$  = resonant frequency passage (Hz)  
 $V$  = velocity of sound in air (feet/second)  
 $L$  = length of column (feet)

For air at room temperature, the equation becomes:

$$F_r = \frac{3300}{L}$$

Where:  $L$  = passage length (inches)

The natural frequency and approximately fastest pressure step rise time for various length passages are shown in the following chart, using a medium of air at 77°F (25°C).

**Selected Values for 77°F (25°C)**

Passage length (inches)	Passage resonance (kHz)	Approx. fastest pulse rise time (microseconds)
.050	66	5
.100	33	10
.200	16.5	20
.50	6.6	50
1.0	3.3	100

Measured resonant frequencies may differ slightly from the chart values due to variations in the velocity of sound in the air from changes in temperature and pressure of the air in the passage.

If possible, keep passage lengths below 0.10 inches (.254 mm) for best results in most ballistic applications, especially at the casemouth and when measuring port pressures.

**3.4 Flush Mount**

The flush mount installation is intended for tangential shot shell pressure measurement and there is no reduced area passage from the sensor diaphragm to the test chamber. Instead, the sensor diaphragm is mounted flush with, or slightly recessed from, the inside surface of the test chamber. See Figure 3.3.

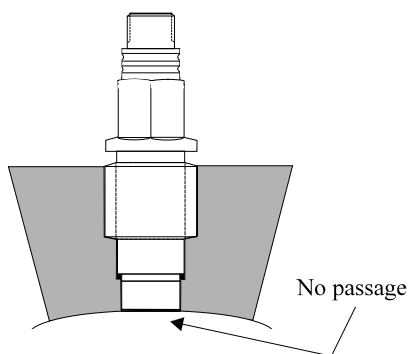

**Figure 3.3** Flush Mount

If thermal transients or diaphragm impingement are concerns, use the flush mount technique only when space or rise time considerations preclude the use of the recess mount installation.

**3.5 Flash Thermal Protection**

Additional steps may be taken to provide protection from flash thermal effects. The sensor diaphragm may be thermally insulated with DC-4 silicone grease or its equivalent. In place of the silicone rubber, one layer of black vinyl electrical tape on the diaphragm may provide sufficient insulation.

**3.6 Cable Installation**

Use only low-noise treated coaxial cable (PCB Model 003A or equivalent) to connect the transducer to the charge amplifier, in-line voltage amplifier, or other high input impedance readout instrument. For further details on such cabling contact PCB.

Protect the ultra high impedance connection against moisture contamination with shrink tubing or other suitable method. Figures 5.1 and 5.2 illustrate typical circuit connections.

It is advisable to support transducer cables by tying them to rigid structures to prevent excessive motion that can generate noise and materially shorten cable life. Allow adequate strain relief.

**4.0 CALIBRATION**

This transducer can be calibrated using either static hydraulic techniques, such as by a dead weight tester, or by comparison with a standard dial gauge.

Set the charge amplifier for a long time constant, and allow the transducer to thermally stabilize before attempting to calibrate it.



**NOTE:** Do not attempt to use a charge amplifier that has less than a 5 000 second time constant when in the long position.

Several charge amplifiers are specially designed for use with ceramic accelerometers for higher frequency measurements. In general, these types are unsuitable for calibration of quartz pressure transducers by quasi-static means.

A factory charge calibration is supplied with each transducer. Factory recalibration is available.

## 5.0 OPERATION

Most test setups include the Model 165B02 & 118A07 operating into an electrostatic charge amplifier, such as the PCB Model 443B02. See Figure 5.1.

**NOTE:** Keep the input cable to the charge amplifier as short as is practical. Electrical noise at the output of any charge amplifier is directly related to input cable length (capacitance).

Press the ground button of the charge amplifier and adjust electrical zero if necessary. Range the amplifier to give the necessary full-scale voltage. For normal, drift-free operation, switch the charge amplifier time constant selector to MEDIUM or SHORT during use.

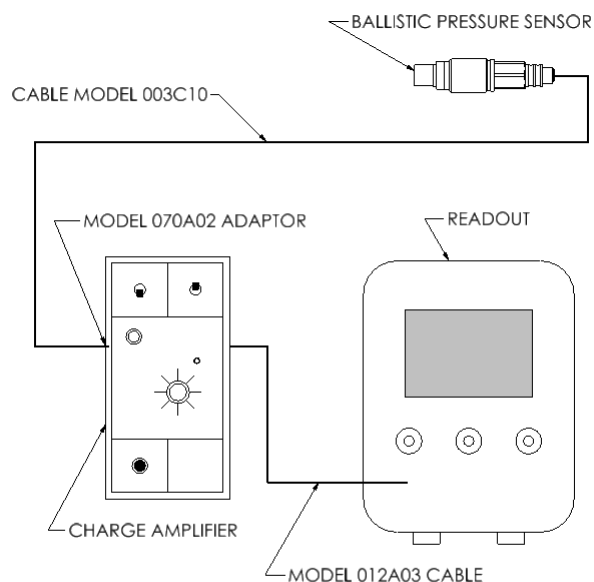

**FIGURE 5.1 TYPICAL CIRCUIT CONNECTION  
LAB-TYPE CHARGE AMPLIFIER**

### 5.1 Polarity

Since most charge amplifiers are inverting amplifiers, the Model 165B02 & 118A07 is designed to produce a negative-going charge for increasing pressure at the diaphragm.

## 6.0 MAINTENANCE

The only maintenance required on the Model 165B02 & 118A07 is the periodic cleaning of the connector to restore insulation resistance.

During use in damp environments or after a period of storage, the insulation resistance of the transducer may degrade ( $10^{12}$  ohms is normal). To restore insulation resistance, an ultrasonic cleaning in 99% pure isopropyl alcohol is required. Then bake the transducer in a 250 °F (121 °C) oven for several hours. If available, a vacuum oven expedites the process. Allow the sensor to cool to ambient temperature before re-testing the insulation resistance.

**Model Number**  
118A07

# CHARGE OUTPUT PRESSURE SENSOR

Revision: E  
ECN #: 49945

	ENGLISH	SI	
<b>Performance</b>			
Sensitivity(± 15 %)	0.28 pC/psi	0.041 pC/kPa	
Measurement Range	15 kpsi	103,400 kPa	
Maximum Pressure	35 kpsi	241,316 kPa	[1]
Resolution	10 mpsi	0.069 kPa	[2]
Resonant Frequency	≥ 175 kHz	≥ 175 kHz	
Rise Time(Reflected)	≤ 2.5 μ sec	≤ 2.5 μ sec	
Non-Linearity	≤ .5 % FS	≤ .5 % FS	[3]
<b>Environmental</b>			
Acceleration Sensitivity	≤ 0.03 psi/g	≤ 0.021 kPa/(m/s <sup>2</sup> )	
Temperature Range(Operating)	-50 to +325 °F	-46 to +163 °C	
Temperature Coefficient of Sensitivity	≤ 0.06 %/°F	≤ 0.108 %/°C	
Maximum Flash Temperature	3,000 °F	1,649 °C	
Maximum Shock	20,000 g pk	196,140 m/s <sup>2</sup> pk	
<b>Electrical</b>			
Output Polarity(Positive Pressure)	Negative	Negative	
Capacitance	5 pF	5 pF	[4]
Insulation Resistance	≥ 10 <sup>12</sup> Ohm	≥ 10 <sup>12</sup> Ohm	
<b>Physical</b>			
Sensing Element	Quartz	Quartz	
Housing Material	Stainless Steel	Stainless Steel	
Diaphragm	Stainless Steel	Stainless Steel	
Sealing	Epoxy	Epoxy	
Electrical Connector	10-32 Coaxial Jack	10-32 Coaxial Jack	
Weight	0.52 oz	14.6 gm	

## OPTIONAL VERSIONS

Optional versions have identical specifications and accessories as listed for the standard model except where noted below. More than one option may be used.

- M** - Metric Mount
- P** - Positive Output Polarity
- W** - Water Resistant Cable

## NOTES:

- [1]Non-Linearity for maximum pressure will be ≤ 2.0%
- [2]Resolution dependent on range setting and cable length used in charge system.
- [3]Zero-based, least-squares, straight line method.
- [4]Typical.
- [5]See PCB Declaration of Conformance PS158 for details.

## SUPPLIED ACCESSORIES:

Model 065A06 Seal ring 0.318" OD x 0.250" ID x 0.010" thk 316L SS material (3)  
Model 065A19 Spacer set, 0.250" ID (1)



Entered: RB	Engineer: RPF	Sales: RWM	Approved: RPF	Spec Number:
Date: 09/11/2019	Date: 09/11/2019	Date: 09/11/2019	Date: 09/11/2019	61551



3425 Walden Avenue, Depew, NY 14043

**Phone: 716-684-0001**  
**Fax: 716-684-0987**  
**E-Mail: info@pcb.com**

All specifications are at room temperature unless otherwise specified.  
In the interest of constant product improvement, we reserve the right to change specifications without notice.  
ICP® is a registered trademark of PCB Piezotronics, Inc.

61577

PCB Piezotronics Inc. claims proprietary rights in the information disclosed hereon. Neither it nor any reproduction thereof will be disclosed to others without the written consent of PCB Piezotronics Inc.

REVISIONS		
REV	DESCRIPTION	DIN
NR	RELEASED TO DRAFTING	44213

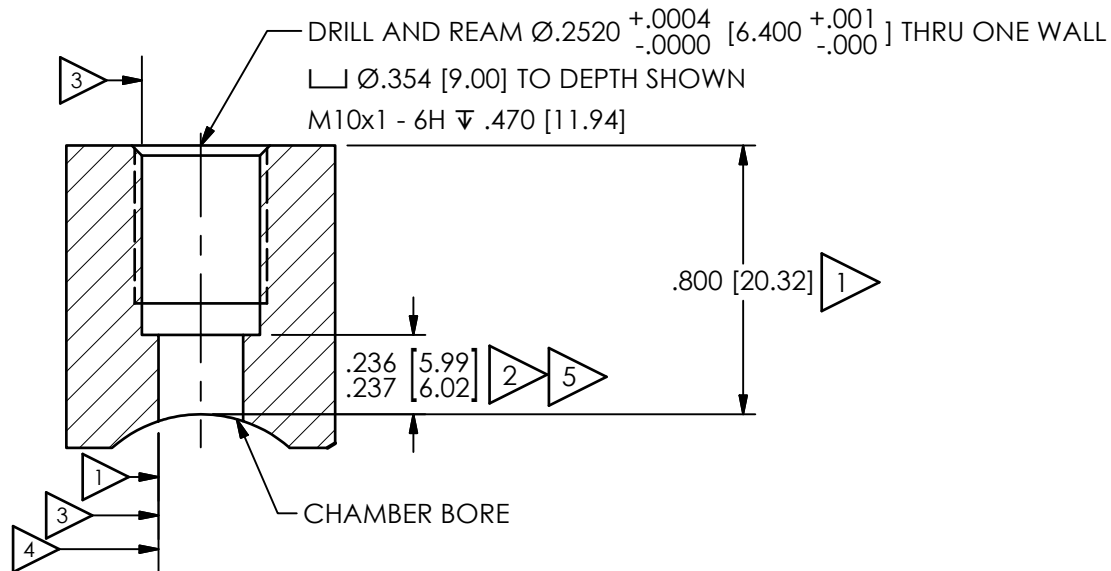

**SHOTSHELL FLUSH MOUNTING**

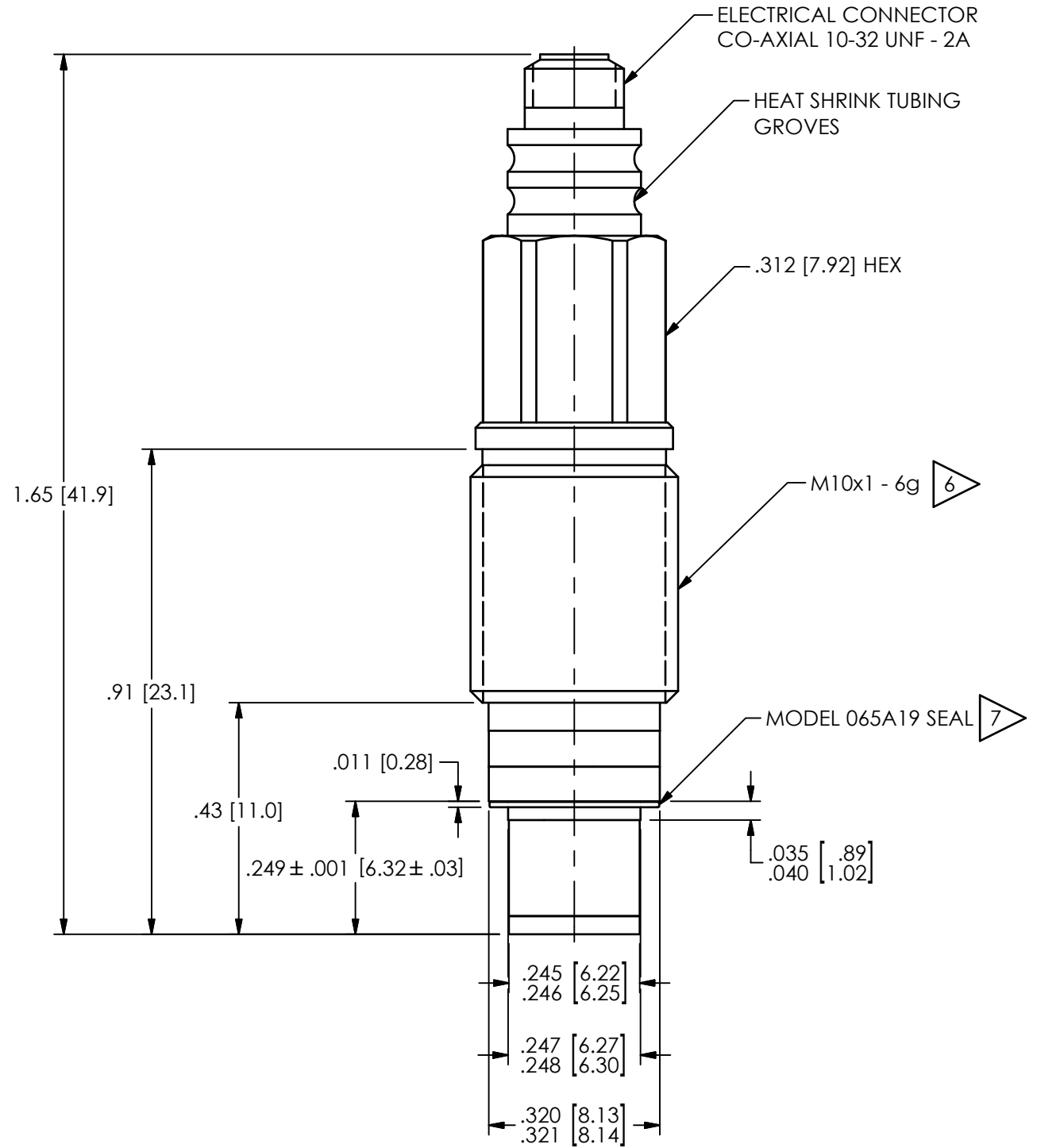

- 7 USE APPROPRIATE 065A19 SPACER TO MOUNT SENSOR TANGENTIALLY FLUSH OR SLIGHTLY RECESSED WITH BORE BARREL
- 6 RECOMMENDED MOUNTING TORQUE 20-24 FT LBS. [27-33 NEWTON METERS]
- 5 HOLD THIS DIMENSION TO OBTAIN FLUSH MOUNT
- 4  $\varnothing$  OF .2520 [6.400] HOLE MUST INTERSECT  $\varnothing$  OF CHAMBER BORE WITHIN .001 [.03] TIR.
- 3 THESE DIAMETERS MUST BE CONCENTRIC TO WITHIN .001 [.03] TIR.
- 2 SEAL SURFACE MUST BE FLAT AND FREE OF TOOL MARKS WITH A MIN  $\sqrt[63]{1.6}$
- 1 DIMENSIONS SHOWN ARE FOR .800 [20.32] THICK WALL.  $\square$  FOR THICKER WALLS

UNLESS OTHERWISE SPECIFIED TOLERANCES ARE:		DRAWN		CHECKED		ENGINEER	
DIMENSIONS IN INCHES	DIMENSIONS IN MILLIMETERS [IN BRACKETS]	BB	6/15/15	ECB	6/15/15	MJK	6/15/15
DECIMALS XX ±.01 XXX ±.005	DECIMALS X ±.03 XX ±.013	TITLE					
ANGLES ± 2 DEGREES	ANGLES ± 2 DEGREES	INSTALLATION DRAWING MODEL M118A07 PRESSURE SENSOR					
FILLETS AND RADII .003 - .005	FILLETS AND RADII 0.07 - 0.13	CODE IDENT. NO. 52681		DWG. NO. 61577			
		SCALE: 4X		SHEET 1 OF 1			

**PCB PIEZOTRONICS™**  
 3425 WALDEN AVE. DEPEW, NY 14043  
 (716) 684-0001 E-MAIL: sales@pcb.com