



Model TLD288D01
Mechanical Impedance Sensor
Installation and Operating Manual

**For assistance with the operation of this product,
contact PCB Piezotronics, Inc.**

Toll-free: 800-828-8840
24-hour SensorLine: 716-684-0001
Fax: 716-684-0987
E-mail: info@pcb.com
Web: www.pcb.com





Service, Repair, and Return Policies and Instructions
--

The information contained in this document supersedes all similar information that may be found elsewhere in this manual.

Service – Due to the sophisticated nature of the sensors and associated instrumentation provided by PCB Piezotronics, user servicing or repair is not recommended and, if attempted, may void the factory warranty. Routine maintenance, such as the cleaning of electrical connectors, housings, and mounting surfaces with solutions and techniques that will not harm the physical material of construction, is acceptable. Caution should be observed to ensure that liquids are not permitted to migrate into devices that are not hermetically sealed. Such devices should only be wiped with a dampened cloth and never submerged or have liquids poured upon them.

Repair – In the event that equipment becomes damaged or ceases to operate, arrangements should be made to return the equipment to PCB Piezotronics for repair. User servicing or repair is not recommended and, if attempted, may void the factory warranty.

Calibration – Routine calibration of sensors and associated instrumentation is recommended as this helps build confidence in measurement accuracy and acquired data. Equipment calibration cycles are typically established by the users own quality regimen. When in doubt about a calibration cycle, a good “rule of thumb” is to recalibrate on an annual basis. It is

also good practice to recalibrate after exposure to any severe temperature extreme, shock, load, or other environmental influence, or prior to any critical test.

PCB Piezotronics maintains an ISO-9001 certified metrology laboratory and offers calibration services, which are accredited by A2LA to ISO/IEC 17025, with full traceability to SI through N.I.S.T. In addition to the normally supplied calibration, special testing is also available, such as: sensitivity at elevated or cryogenic temperatures, phase response, extended high or low frequency response, extended range, leak testing, hydrostatic pressure testing, and others. For information on standard recalibration services or special testing, contact your local PCB Piezotronics distributor, sales representative, or factory customer service representative.

Returning Equipment – *Following these procedures will ensure that your returned materials are handled in the most expedient manner.* Before returning any equipment to PCB Piezotronics, contact your local distributor, sales representative, or factory customer service representative to obtain a Return **Warranty, Service, Repair, and Return Policies and Instructions** Materials Authorization (RMA) Number. This RMA number should be clearly marked on the outside of all package(s) and on the packing

list(s) accompanying the shipment. A detailed account of the nature of the problem(s) being experienced with the equipment should also be included inside the package(s) containing any returned materials.

A Purchase Order, included with the returned materials, will expedite the turn-around of serviced equipment. It is recommended to include authorization on the Purchase Order for PCB to proceed with any repairs, as long as they do not exceed 50% of the replacement cost of the returned item(s). PCB will provide a price quotation or replacement recommendation for any item whose repair costs would exceed 50% of replacement cost, or any item that is not economically feasible to repair. For routine calibration services, the Purchase Order should include authorization to proceed and return at current pricing, which can be obtained from a factory customer service representative.

Contact Information – International customers should direct all inquiries to their local distributor or sales office. A

complete list of distributors and offices can be found at www.pcb.com. Customers within the United States may contact their local sales representative or a factory customer service representative. A complete list of sales representatives can be found at www.pcb.com. Toll-free telephone numbers for a factory customer service representative, in the division responsible for this product, can be found on the title page at the front of this manual. Our ship to address and general contact numbers are:

PCB Piezotronics, Inc.
3425 Walden Ave.
Depew, NY14043 USA
Toll-free: (800) 828-8840
24-hour SensorLineSM: (716) 684-0001
Website: www.pcb.com
E-mail: info@pcb.com



PCB工业监视和测量设备 - 中国RoHS2公布表
 PCB Industrial Monitoring and Measuring Equipment - China RoHS 2 Disclosure Table

部件名称	有害物质					
	铅 (Pb)	汞 (Hg)	镉 (Cd)	六价铬 (Cr(VI))	多溴联苯 (PBB)	多溴二苯醚 (PBDE)
住房	○	○	○	○	○	○
PCB板	X	○	○	○	○	○
电气连接器	○	○	○	○	○	○
压电晶体	X	○	○	○	○	○
环氧	○	○	○	○	○	○
铁氟龙	○	○	○	○	○	○
电子	○	○	○	○	○	○
厚膜基板	○	○	X	○	○	○
电线	○	○	○	○	○	○
电缆	X	○	○	○	○	○
塑料	○	○	○	○	○	○
焊接	X	○	○	○	○	○
铜合金/黄铜	X	○	○	○	○	○
本表格依据 SJ/T 11364 的规定编制。						
○：表示该有害物质在该部件所有均质材料中的含量均在 GB/T 26572 规定的限量要求以下。						
X：表示该有害物质至少在该部件的某一均质材料中的含量超出 GB/T 26572 规定的限量要求。						
铅是欧洲RoHS指令2011/65/ EU附件三和附件四目前由于允许的豁免。						

CHINA RoHS COMPLIANCE

Component Name	Hazardous Substances					
	Lead (Pb)	Mercury (Hg)	Cadmium (Cd)	Chromium VI Compounds (Cr(VI))	Polybrominated Biphenyls (PBB)	Polybrominated Diphenyl Ethers (PBDE)
Housing	O	O	O	O	O	O
PCB Board	X	O	O	O	O	O
Electrical Connectors	O	O	O	O	O	O
Piezoelectric Crystals	X	O	O	O	O	O
Epoxy	O	O	O	O	O	O
Teflon	O	O	O	O	O	O
Electronics	O	O	O	O	O	O
Thick Film Substrate	O	O	X	O	O	O
Wires	O	O	O	O	O	O
Cables	X	O	O	O	O	O
Plastic	O	O	O	O	O	O
Solder	X	O	O	O	O	O
Copper Alloy/Brass	X	O	O	O	O	O

This table is prepared in accordance with the provisions of SJ/T 11364.

O: Indicates that said hazardous substance contained in all of the homogeneous materials for this part is below the limit requirement of GB/T 26572.

X: Indicates that said hazardous substance contained in at least one of the homogeneous materials for this part is above the limit requirement of GB/T 26572.

Lead is present due to allowed exemption in Annex III or Annex IV of the European RoHS Directive 2011/65/EU.

DOCUMENT NUMBER: 21354

DOCUMENT REVISION: **D**

ECN: 46162

Table of Contents

Model 288D01

Table of Contents/Appendix	i
1.0 Introduction	1
2.0 Description	1
3.0 Installation	1
4.0 Operation	1
5.0 Maintenance and Repair	1

Appendix

General Operating Guide for use with Piezoelectric ICP® Accelerometers
(Installation, Mounting, Cabling)

Specification Sheet

Installation Drawing

General Signal Conditioning Guide
(Voltage/Charge Amplifiers, Transducer Powering, Cable Driving, Low-Frequency Response)

Supplement to Mounting Accelerometers

Standard Cables

Accessories

Prefix Guide

Warranty, Calibration and Service

Certificate for Free Stinger

Excitation Stinger Data Sheet

Quick Mount Adhesive Kit Data Sheet

Supplied Accessories

Model 081B05 Mounting Stud (2)

Model 080A Adhesive Mounting Base (1)

NIST-Traceable Calibration Certificate

1.0 Introduction

Mechanical structures characteristically transfer motion and force; their product is defined as mechanical energy. By imparting motion and force to a specimen through the impedance head (also known as a driving point sensor) and evaluating the data, a better understanding of the behavior of the test object is achieved.

The term “mechanical impedance” is quite important in analyzing structures and is generally defined as Force divided by Velocity:

$$\text{Mechanical Impedance} = \frac{\text{Force}}{\text{Velocity}}$$

More commonly, however, the input force-to-output motion relationship is viewed at driving points as Acceleration divided by Force. This is properly defined as an inertance frequency response function.

Connection between a stinger or shaker armature and the test specimen is made via the 10-32 tapped holes provided at either end of the Model 288D01.

2.0 Description

Refer to the Installation Drawing provided in this manual for the exact dimensions of the Model 288D01. This unit is designed to maximize stiffness and natural frequency and to minimize mass compensation, cross talk, and transverse sensitivity. The impedance head is engineered to minimize the strain sensitivity of the accelerometer and to reduce the acceleration sensitivity of the force gauge.

The built-in microelectronic amplifiers convert the high-impedance signals generated by the quartz-element force gauge and the ceramic-element accelerometer to low-impedance voltage signals.

If you wish to learn more about sensors with built-in microelectronic circuitry, known as ICP® sensors, consult PCB’s “General Operating Guide for use with Piezoelectric ICP® Accelerometers,” a brochure (included in this manual) outlining the technical specifics associated with piezoelectric sensors. Topics covered include charge versus voltage mode systems, sensor time constants, effect of discharge time constant on low frequency response, and power requirements.

3.0 Installation

For details regarding mounting hole preparation and other installation guidance, consult the Installation Drawing provided in this manual.

It is important to make certain that the mating surfaces at both ends of the Model 288D01 are very flat. While ground surfaces are preferable, satisfactory surfaces may be obtained by other machining techniques, such as turning, milling and spotfacing.

The clearly labeled end of the force sensor should be attached to the test object. Usually, the driving point sensor is connected to the test structure through an adhesive mounting base. The base is typically bonded with an extremely stiff “dental cement” type adhesive. If the sensor is stud mounted, however, tighten to the recommended mounting torque as listed on the Installation Drawing.

NOTE: Ensure that the Model 288D01 is installed properly with the connector end attaching to the stinger. This is unlike the previous versions of impedance heads (Model 288B01 and earlier), which were installed with the connectors closest to the structure interface.

Connect the stinger or shaker armature to the other end. A stinger is a thin, flexible rod that helps ensure that only uniaxial force is applied to the test structure. For more information on stingers, refer to the Excitation Stinger Data Sheet included in this manual.

Caution

When torquing on the sensor, be careful not to damage the connectors with the torque wrench.

NOTE: To avoid any phase shift between force and reference acceleration at higher frequencies, provide a rigid mount between the sensor and the test structure by using a stud or suitably stiff adhesive.

4.0 Operation

Connect the force and acceleration connectors to the respective ICP® signal conditioners using Model 002A Coaxial Cable (or its equivalent). Check to ensure that cable connections are tight.

Most PCB signal conditioners employ a fault-monitoring voltmeter incorporated into the front panel to monitor sensor bias voltage. Normal operation of sensor amplifiers is indicated by a mid-scale reading on this meter.

The outputs of the signal conditioners may be connected directly to the analyzer since the output impedance of the sensor is less than 250 ohms.

5.0 Maintenance and Repair

The sealed construction of the Model 288D01 precludes field maintenance. Should problems occur, contact the factory for instructions on returning the unit for repair or replacement.

MANUAL NUMBER: 18296

MANUAL REVISION: NR

Performance	<u>ENGLISH</u>	<u>SI</u>	
Sensitivity(± 10 %)(Acceleration)	100 mV/g	10.2 mV/(m/s ²)	
Sensitivity(± 10 %)(Force)	100 mV/lb	22.4 mV/N	
Measurement Range(Acceleration)	± 50 g pk	± 490.5 m/s ² pk	
Measurement Range(Force)	± 50 lbf pk	± 222.4 N pk	
Frequency Range(± 5 %)(Acceleration)	1 to 5000 Hz	1 to 5000 Hz	
Frequency Range(± 10 %)(Acceleration)	0.7 to 7000 Hz	0.7 to 7000 Hz	
Rise Time(Force)	<10 µ sec	<10 µ sec	[1]
Resonant Frequency(Mounted)	≥ 20 kHz	≥ 20 kHz	
Resonant Frequency(Unmounted; no load)	>40 kHz	>40 kHz	
Phase Response(± 5 °)	4 to 5000 Hz	4 to 5000 Hz	
Broadband Resolution(1 to 10,000 Hz)	0.002 g rms	0.02 m/s ² rms	[1]
Broadband Resolution	0.002 lb	0.0089 N	[1]
Non-Linearity	± 1 %	± 1 %	[2]
Transverse Sensitivity(to Acceleration)	≤ 5 %	≤ 5 %	
Maximum Force	500 lb	2224 N	
Environmental			
Temperature Range(Operating)	-15 to +200 °F	-26 to +95 °C	
Temperature Response(on Acceleration)	≤ 0.05 %/°F	≤ 0.09 %/°C	[1]
Temperature Response(on Force)	≤ 0.03 %/°F	≤ 0.05 %/°C	[1]
Base Strain Sensitivity	≤ 0.0007 g/µε	≤ 0.007 (m/s ²)/µε	[1]
Maximum Shock	3000 g pk	29,430 m/s ² pk	
Electrical			
Excitation Voltage	22 to 30 VDC	22 to 30 VDC	
Constant Current Excitation	2 to 20 mA	2 to 20 mA	
Discharge Time Constant(Acceleration)	0.4 to 1.5 sec	0.4 to 1.5 sec	
Discharge Time Constant(Force)	≥ 60 sec	≥ 60 sec	
Output Bias Voltage	8 to 14 VDC	8 to 14 VDC	
Output Impedance	<250 Ohm	<250 Ohm	
Output Polarity(Acceleration)	Positive	Positive	
Output Polarity(Force)	Positive	Positive	
Spectral Noise(1 Hz)	200 µg/√Hz	1962 (µm/sec ²)/√Hz	[1]
Spectral Noise(10 Hz)	50 µg/√Hz	490.5 (µm/sec ²)/√Hz	[1]
Spectral Noise(100 Hz)	10 µg/√Hz	98.1 (µm/sec ²)/√Hz	[1]
Spectral Noise(1 kHz)	3 µg/√Hz	29.4 (µm/sec ²)/√Hz	[1]
Physical			
Sensing Element(Acceleration)	Ceramic	Ceramic	
Sensing Element(Force)	Quartz	Quartz	
Sensing Geometry(Acceleration)	Shear	Shear	
Sensing Geometry(Force)	Compression	Compression	
Housing Material	Titanium	Titanium	
Sealing	Welded Hermetic	Welded Hermetic	
Size (Hex x Height)	11/16 in x 0.820 in	11/16 in x 20.83 mm	
Weight	0.68 oz	19.2 gm	[1]
Electrical Connector(Acceleration)	10-32 Coaxial Jack	10-32 Coaxial Jack	
Electrical Connector(Force)	10-32 Coaxial Jack	10-32 Coaxial Jack	
Mounting Thread(both ends)	10-32 Female	10-32 Female	
Mounting Torque	10 to 20 in-lb	1.1 to 2.2 Nm	
End Plate Mass(Force)	0.16 oz	4.8 gm	[1]
Stiffness	2.0 lb/µin	0.35 kN/µm	[1]

OPTIONAL VERSIONS
Optional versions have identical specifications and accessories as listed for the standard model except where noted below. More than one option may be used.

TLA - TEDS LMS International - Free Format
TLB - TEDS LMS International - Automotive Format
TLC - TEDS LMS International - Aeronautical Format
TLD - TEDS Capable of Digital Memory and Communication Compliant with IEEE 1451.4

Output Bias Voltage 8 to 15 VDC 8 to 15 VDC

NOTES:
[1] Typical.
[2] Zero-based, least-squares, straight line method.
[3] See PCB Declaration of Conformance PS023 for details.

SUPPLIED ACCESSORIES:
Model 080A Adhesive Mounting Base (1)
Model 081B05 Mounting Stud (10-32 to 10-32) (2)
Model HCS-3 NIST Traceable Calibration of Series 288 impedance head (1)
Model M081B05 Mounting Stud 10-32 to M6 X 0.75 (2)

Entered: LK	Engineer: BAM	Sales: KWW	Approved: BAM	Spec Number:
Date: 10/16/2017	Date: 10/16/2017	Date: 10/16/2017	Date: 10/16/2017	6084



All specifications are at room temperature unless otherwise specified.
In the interest of constant product improvement, we reserve the right to change specifications without notice.
ICP® is a registered trademark of PCB Group, Inc.



Phone: 716-684-0001
Fax: 716-684-0987
E-Mail: info@pcb.com

6082

PCB Piezotronics Inc. claims proprietary rights in the information disclosed hereon. Neither it nor any reproduction thereof will be disclosed to others without written consent of PCB Piezotronics Inc.

APPLICATION		
NEXT ASS'Y	USED ON	VAR

REVISIONS				
REV	DESCRIPTION	ECN	DATE	APP'D
C	REVISED PER ECN	14696	2/8/02	DM2/05
D	REVISED PER ECN	22111	5/27/05	EB JMT

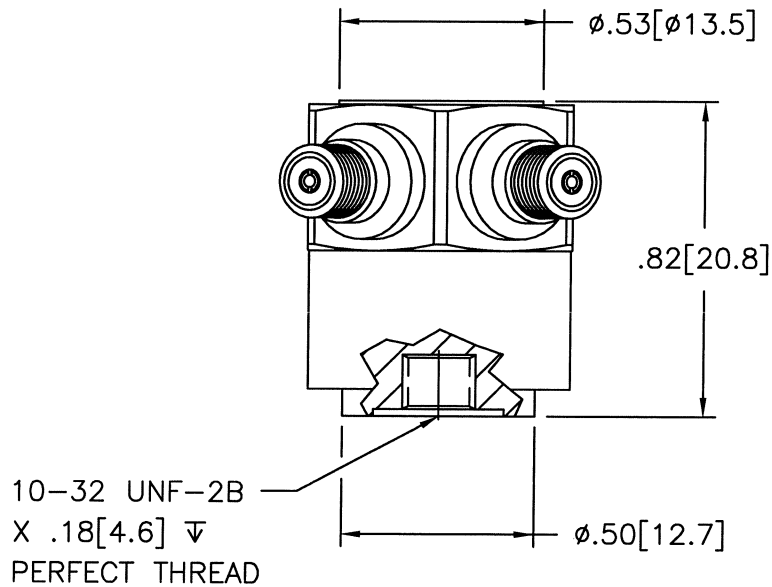
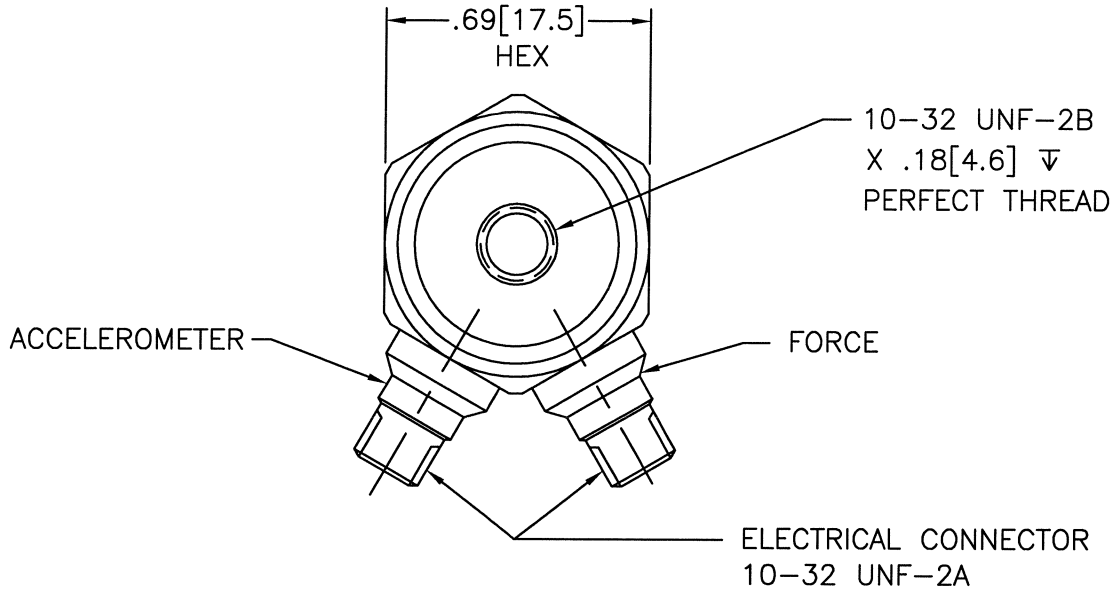

1.) SEE SHEET 2 FOR MOUNTING HOLE PREPARATION.

UNLESS SPECIFIED TOLERANCES		DRAWN	JMT 9/24/05	MFG	RJA 9/27/05	 3425 WALDEN AVE. DEPEW, NY 14043 (716) 684-0001 EMAIL: SALES@PCB.COM
DIMENSIONS IN INCHES	DIMENSIONS IN MILLIMETERS [IN BRACKETS]	CHK'D	ECB 9/26/05	ENGR	JMS 9/26/05	
DECIMALS XX ±.03 XXX ±.010	DECIMALS X ±0.8 XX ±0.25	APP'D	MS 9/29/05	SALES	WJL 9/29/05	
ANGLES ±2 DEGREES	ANGLES ±2 DEGREES	TITLE		INSTALLATION DRAWING MODEL 288D01 SERIES IMPEDANCE HEAD		
FILLET AND RADII .003 - .005	FILLET AND RADII [0.07 - 0.13]	DD011 REV. C 01/21/03	CODE IDENT. NO. 52681		DWG. NO. 6082	SCALE: 2X
						SHEET 1 OF 2

6082

PCB Piezotronics Inc. claims proprietary rights in the information disclosed hereon. Neither it nor any reproduction thereof will be disclosed to others without written consent of PCB Piezotronics Inc.

APPLICATION		
NEXT ASS'Y	USED ON	VAR

REVISIONS				
REV	DESCRIPTION	ECN	DATE	APP'D
	-SEE SHEET ONE-			

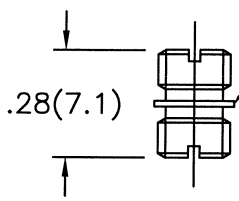
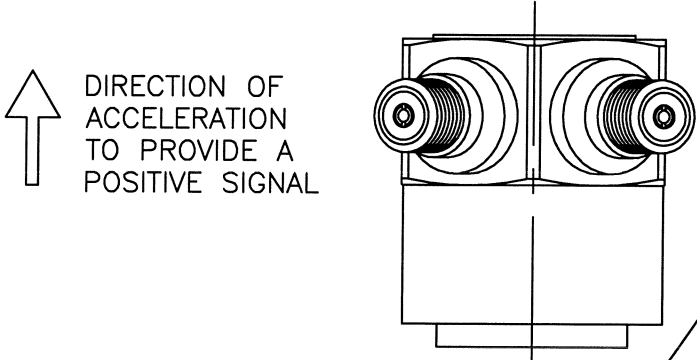

MODEL 081B05
MOUNTING STUD
10-32 UNF-2A
TYPICAL EACH END
(2 SUPPLIED)

MODEL M081B05
METRIC MOUNTING STUD
10-32 UNF-2A TO
M6 X 0.75-6g
(2 SUPPLIED)

MOUNTING HOLE PREPARATION:

081B05 STUD:
 $\phi .159[\phi 4.04]$ $\nabla 1$
 X .23[5.8] ∇ MIN.
 10-32 UNF-2B
 X .15[3.8] ∇ MIN.

M081B05 STUD:
 $\phi .209[\phi 5.3]$
 X .30[7.6] ∇ MIN.
 M6 X 0.75-6H
 X .20[5.1] ∇ MIN.

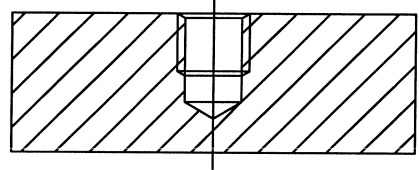

TYPICAL STUD INSTALLATION

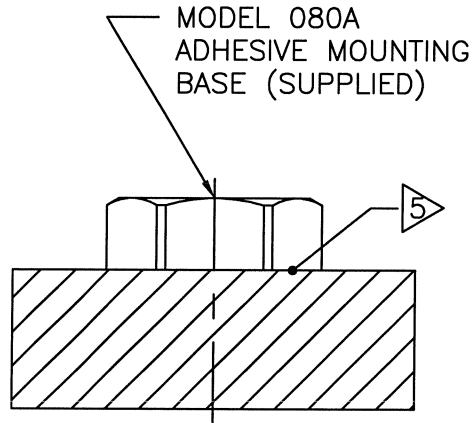

TYPICAL ADHESIVE INSTALLATION

- $\nabla 5$ APPLY A THIN LAYER OF EPOXY, DENTAL CEMENT, OR SIMILAR ADHESIVE.
- 4.) FOR BEST RESULTS, PLACE A THIN LAYER OF SILICONE GREASE ON SENSOR INTERFACE PRIOR TO MOUNTING.
- 3.) RECOMMENDED SENSOR MOUNTING TORQUE 10-20 INCH POUNDS [113-225 NEWTON CENTIMETERS].
- $\nabla 2$ MOUNTING SURFACE SHOULD BE FLAT TO WITHIN .001[0.03] TIR OVER $\phi .50[\phi 12.7]$ WITH A MINIMUM 63/[1,6/] FINISH FOR BEST RESULTS.
- $\nabla 1$ DRILL PERPENDICULAR TO MOUNTING SURFACE TO WITHIN $\pm 1^\circ$.

UNLESS SPECIFIED TOLERANCES		DRAWN <i>JRM</i> 9/26/05		MFG <i>RJA</i> 7/29/05		 3425 WALDEN AVE. DEPEW, NY 14043 (716) 684-0001 EMAIL: SALES@PCB.COM	
DIMENSIONS IN INCHES	DIMENSIONS IN MILLIMETERS [IN BRACKETS]	CHK'D <i>ECB</i> 9/26/05	ENGR <i>SMB</i> 9/26/05	SALES <i>WJL</i> 9/26/05	CODE IDENT. NO. 52681		
DECIMALS XX $\pm .03$ XXX $\pm .010$	DECIMALS X ± 0.8 XX ± 0.25	APP'D <i>JRM</i> 9/26/05	TITLE INSTALLATION DRAWING MODEL 288D01 SERIES IMPEDANCE HEAD		SCALE: 2X		SHEET 2 OF 2
ANGLES ± 2 DEGREES	ANGLES ± 2 DEGREES	FILLETS AND RADII .003 - .005		FILLETS AND RADII [0.07 - 0.13]		DD011 REV. C 01/21/03	